





**J30-06 CONTINUOUS
CONCRETE SLAB
BRIDGE STANDARDS**

INDEX FOR J30-06 STANDARDS:

J30-01-06	INDEX SHEET	
J30-01A-06	GENERAL NOTES	
J30-02B-06	SUPERSTRUCTURE DETAILS	70'-0 BRIDGE - NON-EPOXY COATED REINFORCING
J30-02E-06	SUPERSTRUCTURE DETAILS	70'-0 BRIDGE - EPOXY COATED REINFORCING
J30-03B-06	SUPERSTRUCTURE DETAILS	70'-0 BRIDGE - NON-EPOXY COATED REINFORCING
J30-03E-06	SUPERSTRUCTURE DETAILS	70'-0 BRIDGE - EPOXY COATED REINFORCING
J30-04B-06	SUPERSTRUCTURE DETAILS	80'-0 BRIDGE - NON-EPOXY COATED REINFORCING
J30-04E-06	SUPERSTRUCTURE DETAILS	80'-0 BRIDGE - EPOXY COATED REINFORCING
J30-05B-06	SUPERSTRUCTURE DETAILS	80'-0 BRIDGE - NON-EPOXY COATED REINFORCING
J30-05E-06	SUPERSTRUCTURE DETAILS	80'-0 BRIDGE - EPOXY COATED REINFORCING
J30-06B-06	SUPERSTRUCTURE DETAILS	90'-0 BRIDGE - NON-EPOXY COATED REINFORCING
J30-06E-06	SUPERSTRUCTURE DETAILS	90'-0 BRIDGE - EPOXY COATED REINFORCING
J30-07B-06	SUPERSTRUCTURE DETAILS	90'-0 BRIDGE - NON-EPOXY COATED REINFORCING
J30-07E-06	SUPERSTRUCTURE DETAILS	90'-0 BRIDGE - EPOXY COATED REINFORCING
J30-08B-06	SUPERSTRUCTURE DETAILS	100'-0 BRIDGE - NON-EPOXY COATED REINFORCING
J30-08E-06	SUPERSTRUCTURE DETAILS	100'-0 BRIDGE - EPOXY COATED REINFORCING
J30-09B-06	SUPERSTRUCTURE DETAILS	100'-0 BRIDGE - NON-EPOXY COATED REINFORCING
J30-09E-06	SUPERSTRUCTURE DETAILS	100'-0 BRIDGE - EPOXY COATED REINFORCING
J30-10B-06	SUPERSTRUCTURE DETAILS	110'-0 BRIDGE - NON-EPOXY COATED REINFORCING
J30-10E-06	SUPERSTRUCTURE DETAILS	110'-0 BRIDGE - EPOXY COATED REINFORCING
J30-11B-06	SUPERSTRUCTURE DETAILS	110'-0 BRIDGE - NON-EPOXY COATED REINFORCING
J30-11E-06	SUPERSTRUCTURE DETAILS	110'-0 BRIDGE - EPOXY COATED REINFORCING
J30-12B-06	SUPERSTRUCTURE DETAILS	120'-0 BRIDGE - NON-EPOXY COATED REINFORCING
J30-12E-06	SUPERSTRUCTURE DETAILS	120'-0 BRIDGE - EPOXY COATED REINFORCING
J30-13B-06	SUPERSTRUCTURE DETAILS	120'-0 BRIDGE - NON-EPOXY COATED REINFORCING
J30-13E-06	SUPERSTRUCTURE DETAILS	120'-0 BRIDGE - EPOXY COATED REINFORCING
J30-14B-06	SUPERSTRUCTURE DETAILS	130'-0 BRIDGE - NON-EPOXY COATED REINFORCING
J30-14E-06	SUPERSTRUCTURE DETAILS	130'-0 BRIDGE - EPOXY COATED REINFORCING
J30-15B-06	SUPERSTRUCTURE DETAILS	130'-0 BRIDGE - NON-EPOXY COATED REINFORCING
J30-15E-06	SUPERSTRUCTURE DETAILS	130'-0 BRIDGE - EPOXY COATED REINFORCING
J30-16B-06	SUPERSTRUCTURE DETAILS	140'-0 BRIDGE - NON-EPOXY COATED REINFORCING
J30-16E-06	SUPERSTRUCTURE DETAILS	140'-0 BRIDGE - EPOXY COATED REINFORCING
J30-17B-06	SUPERSTRUCTURE DETAILS	140'-0 BRIDGE - NON-EPOXY COATED REINFORCING
J30-17E-06	SUPERSTRUCTURE DETAILS	140'-0 BRIDGE - EPOXY COATED REINFORCING
J30-18B-06	SUPERSTRUCTURE DETAILS	150'-0 BRIDGE - NON-EPOXY COATED REINFORCING
J30-18E-06	SUPERSTRUCTURE DETAILS	150'-0 BRIDGE - EPOXY COATED REINFORCING
J30-19B-06	SUPERSTRUCTURE DETAILS	150'-0 BRIDGE - NON-EPOXY COATED REINFORCING
J30-19E-06	SUPERSTRUCTURE DETAILS	150'-0 BRIDGE - EPOXY COATED REINFORCING
J30-20-06	SUPERSTRUCTURE DETAILS ALL BRIDGES	
J30-21-06	SUPERSTRUCTURE DETAILS ALL BRIDGES	
J30-22-06	SUPERSTRUCTURE DETAILS ALL BRIDGES	
J30-23-06	MONOLITHIC PIER CAP DETAILS ALL BRIDGES	
J30-24-06	MONOLITHIC PIER CAP DETAILS ALL BRIDGES	
J30-25-06	NON-MONOLITHIC PIER CAP DETAILS ALL BRIDGES	
J30-26-06	NON-MONOLITHIC PIER CAP DETAILS ALL BRIDGES	
J30-27-06	ABUTMENT DETAILS 0° SKEW - TIMBER PILING	
J30-28-06	ABUTMENT DETAILS 15° SKEW - TIMBER PILING	
J30-29-06	ABUTMENT DETAILS 30° SKEW - TIMBER PILING	
J30-30-06	ABUTMENT DETAILS 30° SKEW - TIMBER PILING	
J30-31-06	ABUTMENT DETAILS 45° SKEW - TIMBER PILING	
J30-32-06	ABUTMENT DETAILS 45° SKEW - TIMBER PILING	
J30-33-06	ABUTMENT DETAILS - TIMBER PILING	
J30-34-06	ABUTMENT DETAILS 0° SKEW - STEEL PILING	
J30-35-06	ABUTMENT DETAILS 15° SKEW - STEEL PILING	
J30-36-06	ABUTMENT DETAILS 30° SKEW - STEEL PILING	
J30-37-06	ABUTMENT DETAILS 45° SKEW - STEEL PILING	
J30-38-06	ABUTMENT DETAILS 45° SKEW - STEEL PILING	
J30-39-06	ABUTMENT DETAILS - STEEL PILING	
J30-40-06	BARRIER RAIL DETAILS	
J30-41-06	BARRIER RAIL DETAILS	
J30-42-06	BARRIER RAIL END SECTION	
J30-43-06	OPEN BARRIER RAIL DETAILS	
J30-44-06	OPEN BARRIER RAIL DETAILS	
J30-45-06	SUBDRAIN DETAILS	
J30-46-06	WING ARMORING & MACADAM STONE DETAILS	
J30-47-06	ABUTMENT BACKFILL DETAILS - 0° SKEWS	
J30-48-06	ABUTMENT BACKFILL DETAILS - 15°, 30°, & 45° SKEWS	

REVISED 06-2013; THE GENERAL NOTES AND SPECIFICATIONS MOVED TO STANDARD SHEET J30-01A-06.
REVISED 09-2020; UPDATED BRIDGE ENGINEER SIGNATURE.

09-2020 LATEST REVISION DATE	 APPROVED BY BRIDGE ENGINEER	
		STANDARD DESIGN - 30' ROADWAY, 3 SPAN BRIDGES CONTINUOUS CONCRETE SLAB BRIDGES NOVEMBER, 2006
		<table border="1" style="width: 100%;"> <tr> <td style="width: 50%; text-align: center;">INDEX SHEET</td> <td style="width: 50%; text-align: center;">J30-01-06</td> </tr> </table>
INDEX SHEET	J30-01-06	

GENERAL NOTES:

THE J30-06 BRIDGE STANDARDS, IF PROPERLY USED, PROVIDE THE STRUCTURAL PLANS NECESSARY TO CONSTRUCT THREE SPAN 30' ROADWAY CONTINUOUS CONCRETE SLAB BRIDGES WITH LENGTHS OF 70'-0, 80'-0, 90'-0, 100'-0, 110'-0, 120'-0, 130'-0, 140'-0 AND 150'-0.

THESE BRIDGES MAY BE BUILT ON A 0°, 15°, 30° OR 45° SKEW. THESE PLANS SHOW THE BRIDGES SKEWED IN ONE DIRECTION, BUT ALL DIMENSIONS AND DETAILS WOULD BE THE SAME FOR THE OPPOSITE SKEW.

THESE STANDARDS GIVE MOST OF THE INFORMATION NECESSARY TO BUILD THESE BRIDGES. HOWEVER, THE FOLLOWING ADDITIONAL INFORMATION IS REQUIRED FOR USE ON PRIMARY ROUTES. FOR SECONDARY ROUTES THE ENGINEER MAY NOT REQUIRE ALL SHEETS TO BE PROVIDED:

1. TITLE SHEET WITH ENGINEERS SEAL
2. ESTIMATED QUANTITIES TOTALS INCLUDING CLASS 20 EXCAVATION FOR BRIDGE
3. SITUATION PLAN LAYOUT OF BRIDGE
4. TOP OF SLAB ELEVATIONS LAYOUT
5. BOTTOM OF ABUTMENT FOOTING ELEVATIONS
6. BOTTOM OF PIER CAP ELEVATIONS
7. PILING DESIGN INFORMATION
8. SLOPE PROTECTION LAYOUT IF NEEDED
9. CONDUIT LAYOUT
10. LIGHTING LAYOUT IF NEEDED

FOR CLARITY, MOST SECTIONS SHOWN ON THE FOLLOWING SHEETS ARE DRAWN WITH BARRIER RAIL ONLY. THESE SECTIONS WILL BE IDENTICAL FOR OPEN RAIL DESIGN WITH ANY MODIFICATIONS SHOWN ON SHEET J30-43-06 AND J30-44-06.

THESE BRIDGES ARE DESIGNED FOR HL93 LOADING PLUS 20 LBS. PER SQ. FT. OF ROADWAY FOR FUTURE WEARING SURFACE. CONTROL OF CRACKING BY DISTRIBUTION OF REINFORCEMENT FOR SLAB DESIGN BASED ON PRE LRFD 2005 INTERIMS.

NOTE THAT WHEN APPROACH PAVEMENT IS TO BE PLACED, THE TEMPORARY PAVING BLOCKS SHALL BE REMOVED AND A PROPER JOINT FOR EXPANSION SHALL BE PROVIDED BETWEEN THE BRIDGE AND THE APPROACH PAVING.

THE FLOOR SLAB AS SHOWN INCLUDES 1/2" INTEGRAL WEARING SURFACE.

THE ABUTMENTS FOR THESE BRIDGES ARE BUILT INTEGRAL WITH THE SUPERSTRUCTURE. THEREFORE, IT IS IMPORTANT THAT A PROPER JOINT FOR EXPANSION BE PROVIDED BETWEEN THE BRIDGE AND APPROACH PAVING, WHEN APPROACH PAVING IS NEEDED.

THE ABUTMENT DESIGN UTILIZED ON THESE BRIDGES RESTRICTS THEIR USE IN THE FOLLOWING MANNER:

- (1) THESE BRIDGES ARE NOT TO BE USED WHEN POINT BEARING FOR THE ABUTMENT STEEL PILING WOULD BE OBTAINED ON ROCK AT A DISTANCE LESS THAN 15 FEET FROM THE BOTTOM OF FOOTING.
- (2) FOR THE 140 FOOT AND 150 FOOT LONG BRIDGES THE ABUTMENT PILING ARE TO BE DRIVEN THROUGH OVERSIZED HOLES PREBORED TO A MINIMUM OF 10 FEET BELOW THE BELOW THE BOTTOM OF FOOTING. THE PREBORED HOLES SHALL BE IN ACCORDANCE WITH SECTION 2501.03, Q OF THE STANDARD SPECIFICATIONS. THE ELEVATION OF THE BOTTOM OF THE PREBORED HOLE SHALL BE SHOWN ON THE PLANS.
- (3) IF ROCK IS ENCOUNTERED LESS THAN 5 FOOT BELOW THE PREBORED HOLES, A SPECIAL ANALYSIS WILL BE REQUIRED. WHEN PREBORING IS NOT REQUIRED FOR THE ABUTMENT FOOTING AND ROCK IS ENCOUNTERED LESS THAN 10 FOOT BELOW THE BOTTOM OF ABUTMENT FOOTING, A SPECIAL ANALYSIS WILL BE REQUIRED.

THE PIERS AND ABUTMENTS FOR THESE STANDARDS HAVE BEEN DESIGNED FOR THE USE OF BOTH FRICTION AND POINT BEARING PILES. IT IS NECESSARY THAT THE TYPE AND LENGTH FOR BOTH THE ABUTMENT AND PIER PILES BE DESIGNATED ON THE FRONT SHEET OF THE PLANS.

THE INTEGRAL ABUTMENTS AND PILE BENTS FOR THESE J30 STANDARDS HAVE BEEN DESIGNED FOR THE USE OF VARIOUS TYPES OF PILE FOOTINGS AS FOLLOWS.

- INTEGRAL ABUTMENTS: TIMBER PILES OR HP 10x42 PILES AT BRIDGE DESIGN MANUAL(BDM) ARTICLE 6.2.6.1 STRUCTURAL RESISTANCE LEVEL-I (SRL-I)
- PILE BENTS: STANDARD CONCRETE-FILLED STEEL PIPE PILES (PIOL), STANDARD PRESTRESSED CONCRETE PILES (PIOL), OR STANDARD H-PILES (PIOL AND SRL-I)

BECAUSE THESE BRIDGE STANDARDS HAVE BEEN REVISED FOR LRFD BASED ON 2012-COMPLETED IOWA STATE UNIVERSITY RESEARCH, FOR PILE FOUNDATIONS THE DESIGNER WILL NEED TO DETERMINE THE CONSTRUCTION CONTROL METHOD, CONTRACT LENGTH, AND DRIVING TARGET AND GIVE THAT INFORMATION ON THE FRONT SHEET OF THE PLANS. BRIDGE DESIGN MANUAL CADD NOTES E177, E718, E719, E818, AND E819 ARE APPROPRIATE FOR THAT PURPOSE. THE NOTES, AS WELL AS THE BRIDGE DESIGN MANUAL AND DESIGN EXAMPLES, ARE AVAILABLE ON THE OFFICE OF BRIDGES AND STRUCTURES WEB SITE: [HTTP://WWW.IOWADOT.GOV/BRIDGE/INDEX.HTM](http://www.iowadot.gov/bridge/index.htm).

STRUCTURAL RESISTANCE LEVEL-I (SRL-I) REPLACES THE 50 TON STEEL PILE DESIGNATION.

FOR MORE INFORMATION ON SRL-I, SEE THE BRIDGE DESIGN MANUAL, LOCATED ON THE IOWA DEPARTMENT OF TRANSPORTATION, OFFICE OF BRIDGES AND STRUCTURES WEB SITE.

THESE STANDARDS CAN BE USED FOR BRIDGES WITH OR WITHOUT EPOXY COATED REINFORCING. REINFORCING BAR LAP LENGTHS ARE BASED ON THE USE OF EPOXY COATED REINFORCING, BUT NEED NOT BE MODIFIED IF NON-COATED BARS ARE TO BE USED. THE DESIGNER SHALL SPECIFY THE APPROPRIATE BID ITEM NO. FOR THE EPOXY COATED OR NON-EPOXY COATED REINFORCING.

IT IS RECOMMENDED THAT THE EPOXY COATED REINFORCING OPTION BE USED IF IT IS ANTICIPATED THAT THE BRIDGE DECK AND/OR THE BRIDGE APPROACHES WILL BE CHEMICALLY TREATED FOR THE REMOVAL OF ICE OR SNOW.

IF EPOXY COATED BARS ARE USED IN THE DECK, THEN ALL BARS USED IN THE ABUTMENT (FOOTING AND BACKWALL), CAP, AND BARRIER RAILS SHALL BE EPOXY COATED.

FOR PIERS SUBJECT TO SCOUR THE DESIGN BEARING SHALL BE OBTAINED BELOW SCOUR ELEVATION. SCOUR ELEVATION SHALL BE SHOWN ON THE FRONT SHEET.

KEYWAY DIMENSIONS SHOWN ON THE PLANS ARE BASED ON NOMINAL DIMENSIONS UNLESS STATED OTHERWISE. IN ADDITION, THE BEVEL USED ON THE KEYWAY SHALL BE LIMITED TO A MAXIMUM OF 10 DEGREES FROM VERTICAL.

THESE BRIDGE PLANS LABEL ALL REINFORCING STEEL WITH ENGLISH NOTATION (5#1 IS 5/8 INCH DIAMETER BAR). ENGLISH REINFORCING STEEL RECEIVED IN THE FIELD MAY DISPLAY THE FOLLOWING "BAR DESIGNATION". THE "BAR DESIGNATION" IS THE STAMPED IMPRESSION ON THE REINFORCING BARS, AND IS EQUIVALENT TO THE BAR DIAMETER IN MILLIMETERS.

ENGLISH SIZE	3	4	5	6	7	8	9	10	11
BAR DESIGNATION	10	13	16	19	22	25	29	32	36

SPECIFICATIONS:

DESIGN: AASHTO LRFD, SERIES OF 2004 WITH INTERIM 2005.



CONSTRUCTION: IOWA DEPARTMENT OF TRANSPORTATION STANDARD SPECIFICATIONS FOR HIGHWAY AND BRIDGE CONSTRUCTION, SERIES 2012, PLUS APPLICABLE GENERAL SUPPLEMENTAL SPECIFICATIONS, DEVELOPMENTAL SPECIFICATIONS, SUPPLEMENTAL SPECIFICATIONS AND SPECIAL PROVISIONS SHALL APPLY TO CONSTRUCTION WORK ON THIS PROJECT.

DESIGN STRESSES:

DESIGN STRESSES FOR THE FOLLOWING MATERIALS ARE IN ACCORDANCE WITH THE AASHTO LRFD BRIDGE DESIGN SPECIFICATIONS, 3rd Ed, SERIES OF 2004. REINFORCING STEEL IN ACCORDANCE WITH LRFD AASHTO SECTION 5, GRADE 60. CONCRETE IN ACCORDANCE WITH LRFD AASHTO SECTION 5, $f'c = 3,500$ PSI, STRUCTURAL STEEL IN ACCORDANCE WITH LRFD AASHTO SECTION 6. ASTM A709 GRADE 36 OR GRADE 50 (AASHTO M270 GRADE 36 OR GRADE 50).
 $n = 9$ FOR TENSION STEEL
 $2n = 18$ FOR COMPRESSION STEEL
 HL-93 LIVE LOAD PLUS 20 LBS. PER SQ. FT. FOR FUTURE WEARING SURFACE. END SPAN LENGTH IS USED TO CALCULATE EQUIVALENT WIDTH IN LIVE LOAD DISTRIBUTION.

SIX FOOT OF APPROACH SLAB DEAD & LIVE LOAD INCLUDED IN ABUTMENT LOADS. CONTROL OF CRACKING BY DISTRIBUTION OF REINFORCEMENT FOR SLAB DESIGN BASED ON PRE 2005 LRFD INTERMS.

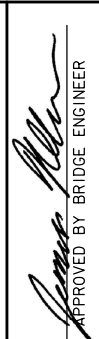
REVISED 06-2013; THIS STANDARD RENAMED TO J30-01A-06. INDEX SHEET INFORMATION ON STANDARD J30-01-06. REVISED 09-2020; UPDATED BRIDGE ENGINEER SIGNATURE.

09-2020 LATEST REVISION DATE	 APPROVED BY BRIDGE ENGINEER		
		STANDARD DESIGN - 30' ROADWAY, 3 SPAN BRIDGES CONTINUOUS CONCRETE SLAB BRIDGES NOVEMBER, 2006	
		GENERAL NOTES	J30-01A-06

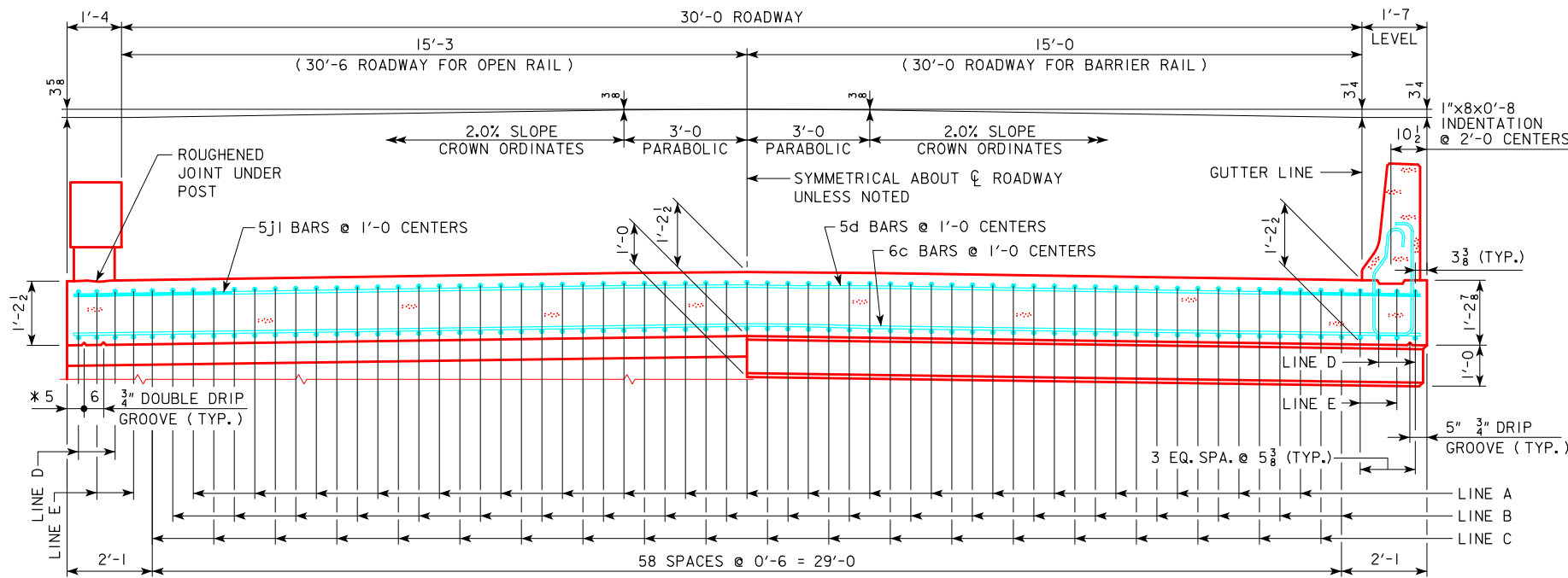

HALF SECTION NEAR ABUTMENT

HALF SECTION NEAR PIER

* NOTE: DOUBLE DRIP GROOVES FOR OPEN RAIL OPTION ONLY.

SLAB CROSS-SECTIONAL AREA FOR OPEN RAIL = 40.08 SQ. FT.

NOTE: TOP LONGITUDINAL REINFORCING STEEL IS TO BE PARALLEL TO AND 2 1/2" CLEAR BELOW TOP OF SLAB. BOTTOM LONGITUDINAL REINFORCING STEEL IS TO BE PARALLEL TO AND 1 1/2" CLEAR ABOVE BOTTOM OF SLAB. REINFORCING STEEL IS TO BE SECURELY WIRED IN PLACE AND ADEQUATELY SUPPORTED ON BAR CHAIRS BEFORE CONCRETE IS POURED. I.M. 451.01 REQUIREMENTS SHALL APPLY FOR BAR CHAIRS.

SLAB CROSS-SECTIONAL AREA FOR BARRIER RAIL = 40.13 SQ. FT.

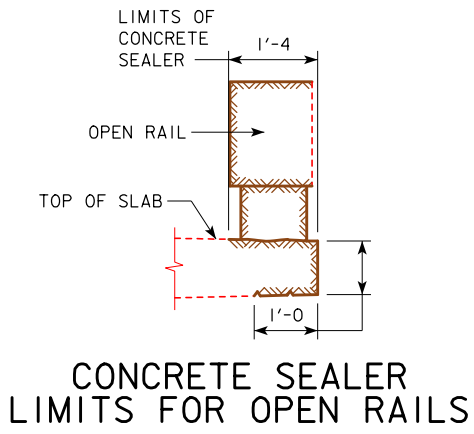

CONCRETE SEALER LIMITS FOR OPEN RAILS

CONCRETE SEALER SHALL BE APPLIED TO BOTH SIDES OF BRIDGE SLAB ON THE TOP, EDGE OF SLAB AND UNDER THE SLAB. THE CONCRETE SEALER SHALL ALSO BE APPLIED TO THE OPEN RAIL ON THE TOP, TRAFFIC FACE SIDE, BOTTOM OF RAIL, AND ON ALL SIDES OF THE OPEN RAIL POSTS.

THE CONCRETE SEALER LIMITS ARE SHOWN IN THE DETAIL AND SHALL APPLY TO THE FULL LENGTH OF BRIDGE. CONCRETE SEALER SHALL BE APPLIED IN ACCORDANCE WITH ARTICLE 2403.03, P, 3 OF THE STANDARD SPECIFICATIONS.

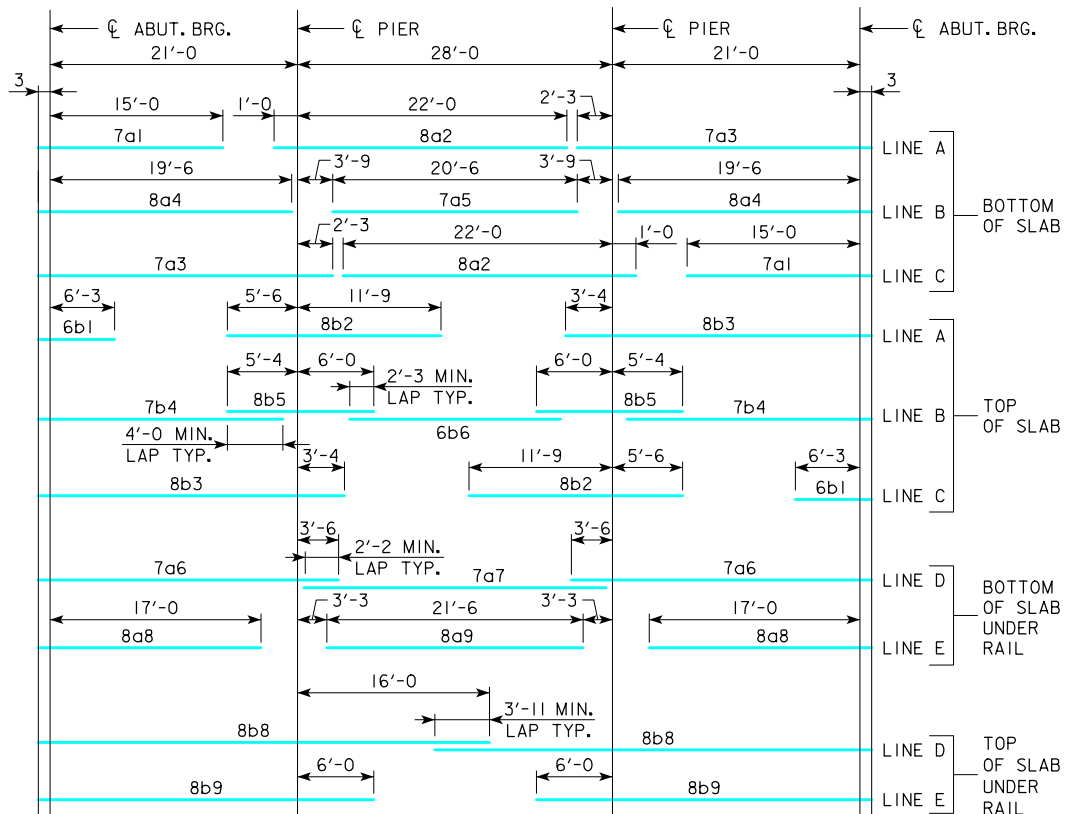

PLACEMENT FOR LONGITUDINAL REINFORCEMENT

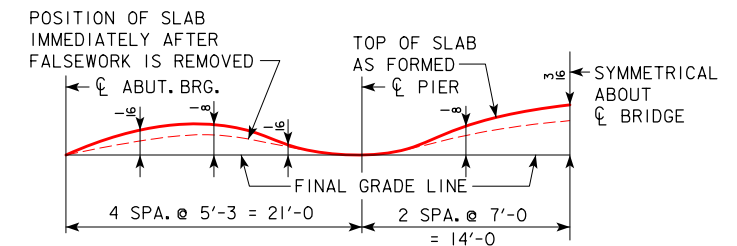

FORM CAMBER DIAGRAM

THIS DIAGRAM SHOWS THE FORM CAMBER REQUIRED TO COMPENSATE FOR THE ANTICIPATED ULTIMATE DEAD LOAD DEFLECTION. THE ABOVE DIMENSIONS DO NOT INCLUDE ANY ALLOWANCE FOR FORM DEFLECTION OR FALSEWORK SETTLEMENT.

REVISID 07-2016; DATE ON SHEET CHANGED TO CORRECT CLERICAL ERROR. REVISED 09-2020; UPDATED BRIDGE ENGINEER SIGNATURE.

09-2020 LATEST REVISION DATE APPROVED BY BRIDGE ENGINEER		
	STANDARD DESIGN - 30' ROADWAY, 3 SPAN BRIDGES CONTINUOUS CONCRETE SLAB BRIDGES NOVEMBER, 2006	
	SUPERSTRUCTURE DETAILS 70'-0 BRIDGE NON-EPOXY COATED REINFORCING	J30-02B-06

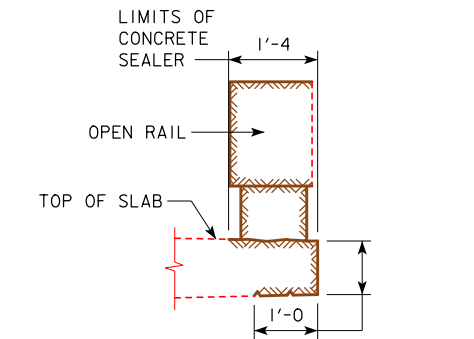
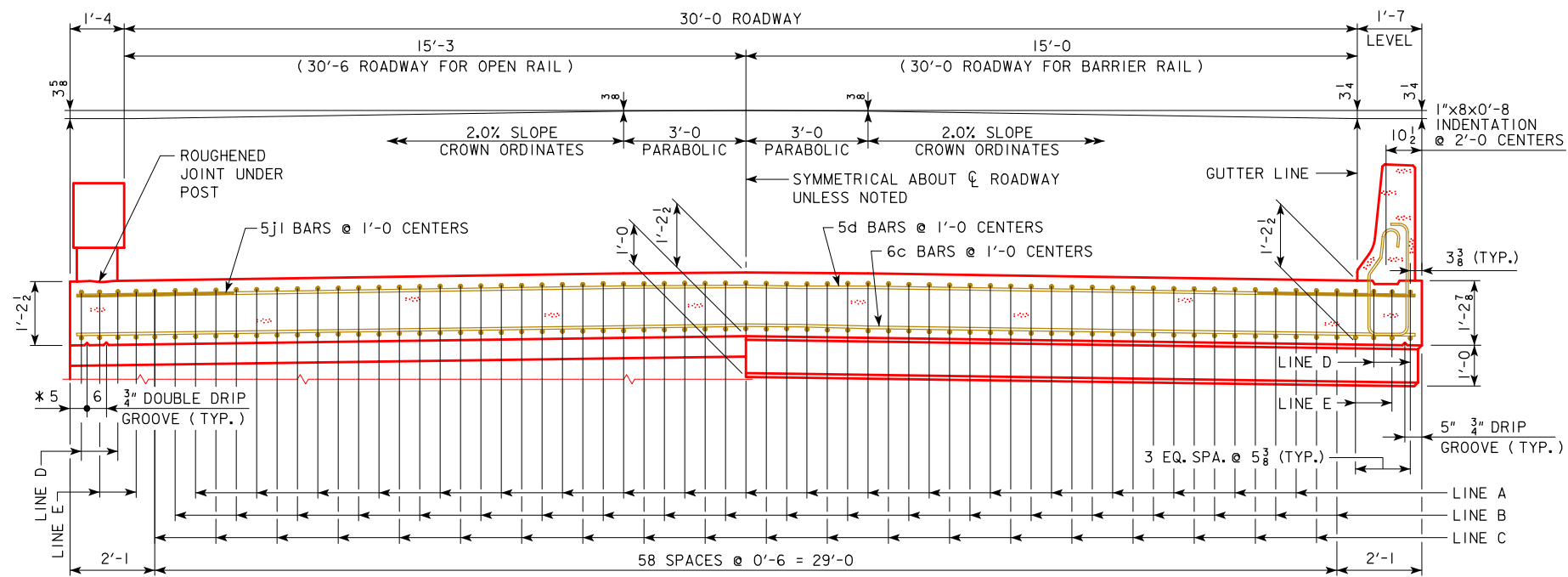

CONCRETE SEALER LIMITS FOR OPEN RAILS

CONCRETE SEALER SHALL BE APPLIED TO BOTH SIDES OF BRIDGE SLAB ON THE TOP, EDGE OF SLAB AND UNDER THE SLAB. THE CONCRETE SEALER SHALL ALSO BE APPLIED TO THE OPEN RAIL ON THE TOP, TRAFFIC FACE SIDE, BOTTOM OF RAIL, AND ON ALL SIDES OF THE OPEN RAIL POSTS.

THE CONCRETE SEALER LIMITS ARE SHOWN IN THE DETAIL AND SHALL APPLY TO THE FULL LENGTH OF BRIDGE. CONCRETE SEALER SHALL BE APPLIED IN ACCORDANCE WITH ARTICLE 2403.03, P, 3 OF THE STANDARD SPECIFICATIONS.

HALF SECTION NEAR ABUTMENT

HALF SECTION NEAR PIER

* NOTE: DOUBLE DRIP GROOVES FOR OPEN RAIL OPTION ONLY.

SLAB CROSS-SECTIONAL AREA FOR OPEN RAIL = 40.08 SQ. FT.

NOTE: TOP LONGITUDINAL REINFORCING STEEL IS TO BE PARALLEL TO AND 2 1/2" CLEAR BELOW TOP OF SLAB. BOTTOM LONGITUDINAL REINFORCING STEEL IS TO BE PARALLEL TO AND 1 1/2" CLEAR ABOVE BOTTOM OF SLAB. REINFORCING STEEL IS TO BE SECURELY WIRED IN PLACE AND ADEQUATELY SUPPORTED ON BAR CHAIRS BEFORE CONCRETE IS POURED. I.M. 451.01 REQUIREMENTS SHALL APPLY FOR BAR CHAIRS.

SLAB CROSS-SECTIONAL AREA FOR BARRIER RAIL = 40.13 SQ. FT.

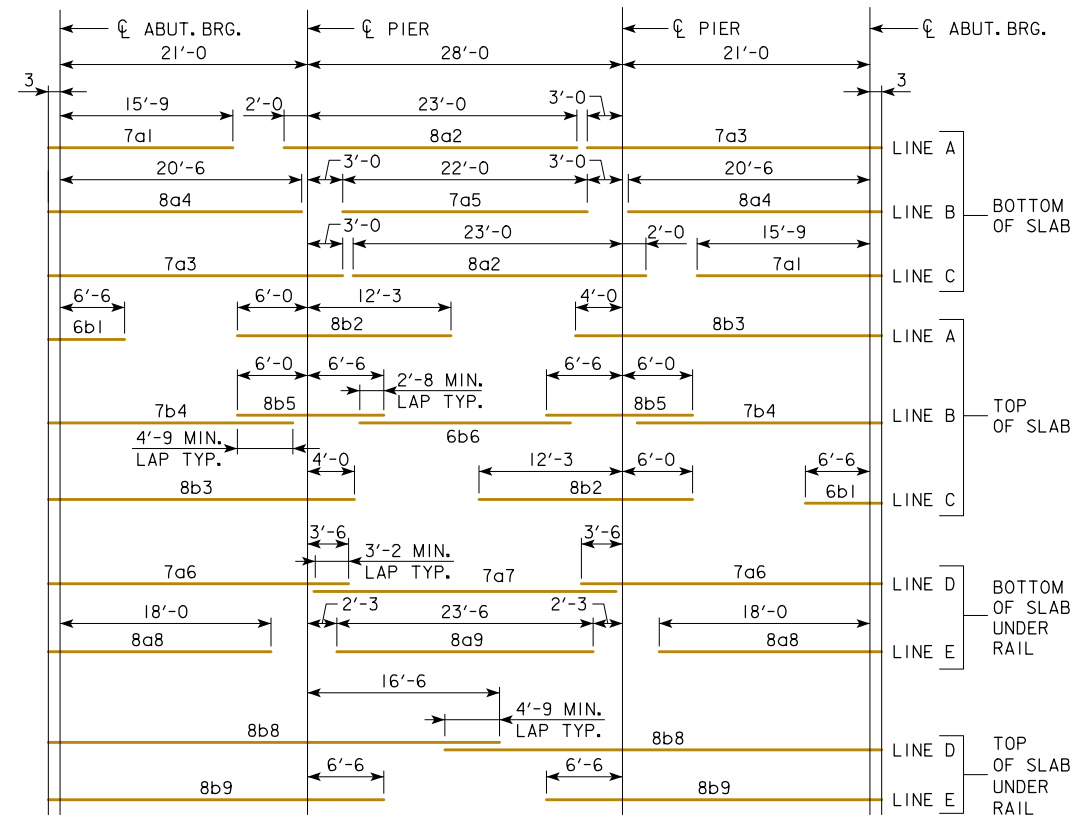

PLACEMENT FOR LONGITUDINAL REINFORCEMENT

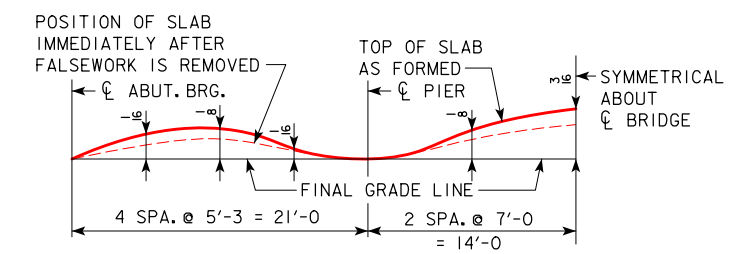

FORM CAMBER DIAGRAM

THIS DIAGRAM SHOWS THE FORM CAMBER REQUIRED TO COMPENSATE FOR THE ANTICIPATED ULTIMATE DEAD LOAD DEFLECTION. THE ABOVE DIMENSIONS DO NOT INCLUDE ANY ALLOWANCE FOR FORM DEFLECTION OR FALSEWORK SETTLEMENT.

REVISED 07-2016; DATE ON SHEET CHANGED TO CORRECT CLERICAL ERROR.
REVISED 09-2020; UPDATED BRIDGE ENGINEER SIGNATURE.

09-2020 LATEST REVISION DATE APPROVED BY BRIDGE ENGINEER		
	STANDARD DESIGN - 30' ROADWAY, 3 SPAN BRIDGES CONTINUOUS CONCRETE SLAB BRIDGES NOVEMBER, 2006	
	SUPERSTRUCTURE DETAILS 70'-0 BRIDGE	J30-02E-06
	EPOXY COATED REINFORCING	

REVISED 07-2009: OPEN RAIL REINF. QTY'S. CHANGED WHICH CHANGED TOTAL REINF. QTY'S.
REVISED 09-2020: UPDATED BRIDGE ENGINEER SIGNATURE. CHANGED PAVING BLOCK LIFTING HOOP BAR MARK, (WAS 5x1).

BILL OF REINFORCING STEEL FOR SUPERSTRUCTURE - 70' BRIDGE

LOCATION	SKEW	SHAPE	BAR	0°				15°				30°				45°			
				NO.	LENGTH	WEIGHT		NO.	LENGTH	WEIGHT		NO.	LENGTH	WEIGHT		NO.	LENGTH	WEIGHT	
SLAB LONGITUDINAL BOTTOM			7a1	39	15'-3	1216		39	15'-3	1216		39	15'-3	1216		39	15'-3	1216	
SLAB LONGITUDINAL BOTTOM			8a2	39	23'-0	2395		39	23'-0	2395		39	23'-0	2395		39	23'-0	2395	
SLAB LONGITUDINAL BOTTOM			7a3	39	23'-6	1874		39	23'-6	1874		39	23'-6	1874		39	23'-6	1874	
SLAB LONGITUDINAL BOTTOM			8a4	40	19'-9	2110		40	19'-9	2110		40	19'-9	2110		40	19'-9	2110	
SLAB LONGITUDINAL BOTTOM			7a5	20	20'-6	839		20	20'-6	839		20	20'-6	839		20	20'-6	839	
SLAB LONGITUDINAL BOTTOM, AT RAIL			7a6	8	24'-9	405		8	24'-9	405		8	24'-9	405		8	24'-9	405	
SLAB LONGITUDINAL BOTTOM, AT RAIL			7a7	4	25'-4	208		4	25'-4	208		4	25'-4	208		4	25'-4	208	
SLAB LONGITUDINAL BOTTOM, AT RAIL			8a8	8	17'-3	369		8	17'-3	369		8	17'-3	369		8	17'-3	369	
SLAB LONGITUDINAL BOTTOM, AT RAIL			8a9	4	21'-6	230		4	21'-6	230		4	21'-6	230		4	21'-6	230	
SLAB LONGITUDINAL TOP			6b1	39	8'-9	513		39	8'-9	513		39	8'-9	513		39	8'-9	513	
SLAB LONGITUDINAL TOP			8b2	39	17'-3	1797		39	17'-3	1797		39	17'-3	1797		39	17'-3	1797	
SLAB LONGITUDINAL TOP			8b3	39	26'-10	2795		39	26'-10	2795		39	26'-10	2795		39	26'-10	2795	
SLAB LONGITUDINAL TOP			7b4	40	22'-2	1813		40	22'-2	1813		40	22'-2	1813		40	22'-2	1813	
SLAB LONGITUDINAL TOP			8b5	40	11'-4	1211		40	11'-4	1211		40	11'-4	1211		40	11'-4	1211	
SLAB LONGITUDINAL TOP			6b6	20	20'-6	616		20	20'-6	616		20	20'-6	616		20	20'-6	616	
SLAB LONGITUDINAL TOP, AT RAIL			8b8	8	39'-6	844		8	39'-6	844		8	39'-6	844		8	39'-6	844	
SLAB LONGITUDINAL TOP, AT RAIL			8b9	8	29'-6	631		8	29'-6	631		8	29'-6	631		8	29'-6	631	
SLAB TRANSVERSE, BOTTOM			6c1	67	32'-10	3305		67	34'-0	3422		54	32'-10	2664		40	32'-10	1973	
SLAB TRANSVERSE ENDS, BOTTOM			6c2	-	-	-		-	-	-		30	VARIES	797		56	VARIES	1486	
SLAB TRANSVERSE, TOP			5d1	67	32'-10	2295		67	34'-0	2376		54	32'-10	1850		40	32'-10	1370	
SLAB TRANSVERSE ENDS, TOP			5d2	-	-	-		-	-	-		30	VARIES	553		56	VARIES	1032	
SLAB, TRANSVERSE AT ABUTMENT			8e1	18	32'-10	1578		-	-	-		-	-	-		-	-	-	
SLAB, TRANSVERSE AT ABUTMENT			8e2	-	-	-		18	33'-11	1631		18	37'-6	1803		18	45'-4	2179	
SLAB, HAIRPINS, AT ABUTMENT			6e3	72	5'-0	541		72	5'-1	550		72	5'-5	586		72	6'-1	658	
SLAB, DIAGONALS, AT ABUTMENT			6e4	72	5'-11	640		72	5'-11	640		72	5'-11	640		72	5'-11	640	
PIER CAP HOOPS			5h1	48	6'-11	347		48	6'-11	347		60	6'-11	433		72	6'-11	520	
PIER CAP ENDS			8h2	4	14'-5	154		4	14'-5	154		4	14'-5	154		4	14'-5	154	
PIER CAP, BOTTOM LONGITUDINAL			8h3	8	29'-10	638		8	30'-11	661		8	34'-5	736		8	42'-2	901	
PIER CAP, TOP LONGITUDINAL			8h4	4	32'-10	351		4	34'-0	364		4	37'-11	405		4	46'-6	497	
TOP OF SLAB, TRANSVERSE, AT RAIL			5j1	132	8'-6	1171		132	8'-6	1171		132	8'-6	1171		130	8'-6	1153	
WING, VERTICAL			5m1	40	4'-5	185		40	4'-5	185		40	4'-5	185		40	4'-5	185	
WING, HORIZONTAL BACK FACE			5n1	24	6'-8	167		24	6'-8	167		24	6'-8	167		24	6'-8	167	
WING, HORIZONTAL TRAFFIC FACE			5n3	24	6'-9	169		24	6'-9	169		24	6'-9	169		24	6'-9	169	
PAVING BLOCK LIFTING HOOPS			5z1	10	2'-10	30		10	2'-10	30		10	2'-10	30		10	2'-10	30	
SUB TOTAL - LBS.						31,437				31,733				32,209				32,980	
BARRIER RAIL - SEE LIST ON RAIL SHEET J30-41-06						4957				4957				4957				4957	
OPEN RAIL - SEE LIST ON RAIL SHEET J30-44-06						5100				5100				5100				5100	
TOTAL - LBS.						36,394				36,690				37,166				37,937	
				WITH MONOLITHIC PIER CAP															
				WITH BARRIER RAIL															
				WITH OPEN RAIL															
TOTAL - LBS.						34,904				35,164				35,438				35,865	
SAME AS ABOVE EXCEPT ALL "h" BARS DELETED						35,047				35,307				35,581				36,008	

ESTIMATED QUANTITIES FOR SUPERSTRUCTURE - 70' BRIDGE

ITEM	SKEW	WITH MONOLITHIC PIER CAP				WITH NON-MONOLITHIC PIER CAP			
		0°	15°	30°	45°	0°	15°	30°	45°
WITH BARRIER RAIL	*STRUCTURAL CONCRETE (BRIDGE) C.Y.	131.2	132.0	134.9	141.0	126.6	127.3	129.6	134.6
CONCRETE BARRIER OR OPEN RAIL	LBS.	36,394	36,690	37,166	37,937	34,904	35,164	35,438	35,865
WITH OPEN RAIL	CONCRETE BARRIER OR OPEN RAIL LIN. FT.	162.0	162.2	162.9	164.5	162.0	162.2	162.9	164.5
WITH BARRIER RAIL	*STRUCTURAL CONCRETE (BRIDGE) C.Y.	131.1	131.9	134.8	140.8	126.5	127.1	129.5	134.5
CONCRETE BARRIER OR OPEN RAIL	LBS.	36,537	36,833	37,309	38,080	35,047	35,307	35,581	36,008

* INCLUDES 4 WINGS @ 0.68 C.Y. EACH AND 2 TEMPORARY PAVING BLOCKS; EXCLUDES RAIL CONCRETE.

BENT BAR DETAILS

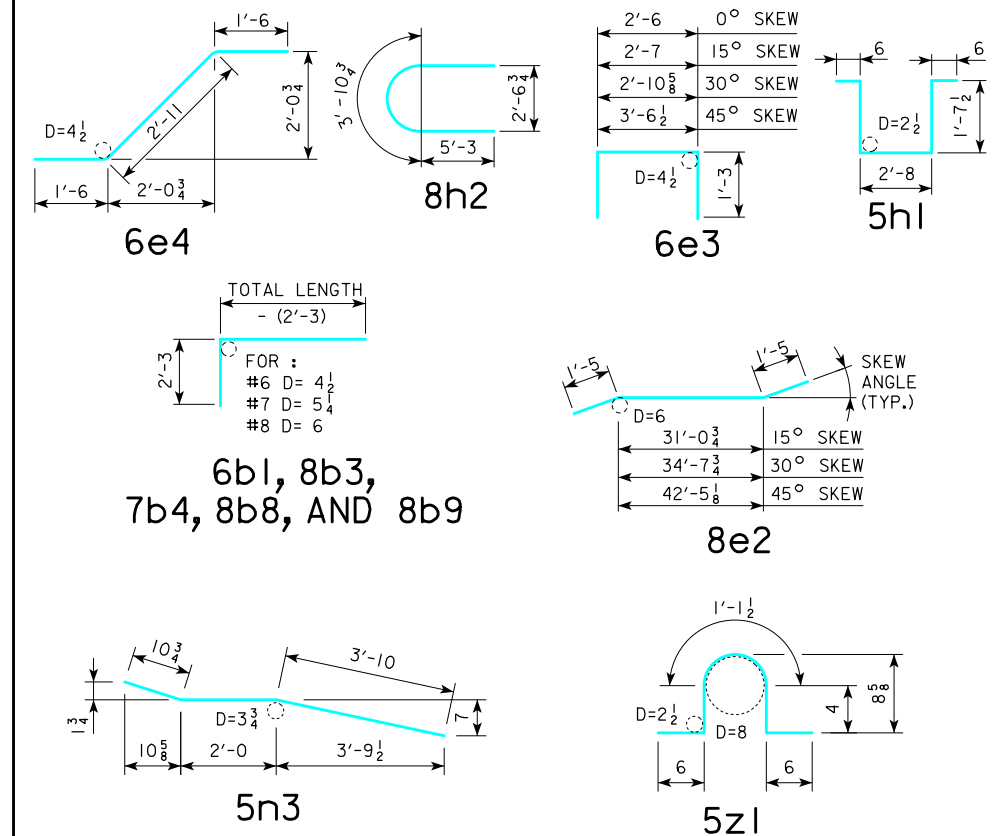

09-2020 LATEST REVISION DATE	APPROVED BY BRIDGE ENGINEER		
		STANDARD DESIGN - 30' ROADWAY, 3 SPAN BRIDGES CONTINUOUS CONCRETE SLAB BRIDGES NOVEMBER, 2006	
		SUPERSTRUCTURE DETAILS 70'-0 BRIDGE	J30-03B-06

NON-EPOXY COATED REINFORCING

BILL OF REINFORCING STEEL FOR SUPERSTRUCTURE - 70' BRIDGE

LOCATION	SKEW	SHAPE	BAR	0°				15°				30°				45°			
				NO.	LENGTH	WEIGHT		NO.	LENGTH	WEIGHT		NO.	LENGTH	WEIGHT		NO.	LENGTH	WEIGHT	
SLAB LONGITUDINAL BOTTOM			7a1	39	16'-0	1276		39	16'-0	1276		39	16'-0	1276		39	16'-0	1276	
SLAB LONGITUDINAL BOTTOM			8a2	39	25'-0	2604		39	25'-0	2604		39	25'-0	2604		39	25'-0	2604	
SLAB LONGITUDINAL BOTTOM			7a3	39	24'-3	1934		39	24'-3	1934		39	24'-3	1934		39	24'-3	1934	
SLAB LONGITUDINAL BOTTOM			8a4	40	20'-9	2217		40	20'-9	2217		40	20'-9	2217		40	20'-9	2217	
SLAB LONGITUDINAL BOTTOM, AT RAIL			7a5	20	22'-0	900		20	22'-0	900		20	22'-0	900		20	22'-0	900	
SLAB LONGITUDINAL BOTTOM, AT RAIL			7a6	8	24'-9	405		8	24'-9	405		8	24'-9	405		8	24'-9	405	
SLAB LONGITUDINAL BOTTOM, AT RAIL			7a7	4	27'-4	224		4	27'-4	224		4	27'-4	224		4	27'-4	224	
SLAB LONGITUDINAL BOTTOM, AT RAIL			8a8	8	18'-3	390		8	18'-3	390		8	18'-3	390		8	18'-3	390	
SLAB LONGITUDINAL BOTTOM, AT RAIL			8a9	4	23'-6	251		4	23'-6	251		4	23'-6	251		4	23'-6	251	
SLAB LONGITUDINAL TOP			6b1	39	9'-0	528		39	9'-0	528		39	9'-0	528		39	9'-0	528	
SLAB LONGITUDINAL TOP			8b2	39	18'-3	1901		39	18'-3	1901		39	18'-3	1901		39	18'-3	1901	
SLAB LONGITUDINAL TOP			8b3	39	27'-6	2864		39	27'-6	2864		39	27'-6	2864		39	27'-6	2864	
SLAB LONGITUDINAL TOP			7b4	40	22'-3	1820		40	22'-3	1820		40	22'-3	1820		40	22'-3	1820	
SLAB LONGITUDINAL TOP			8b5	40	12'-6	1335		40	12'-6	1335		40	12'-6	1335		40	12'-6	1335	
SLAB LONGITUDINAL TOP			6b6	20	20'-4	611		20	20'-4	611		20	20'-4	611		20	20'-4	611	
SLAB LONGITUDINAL TOP, AT RAIL			8b8	8	40'-0	855		8	40'-0	855		8	40'-0	855		8	40'-0	855	
SLAB LONGITUDINAL TOP, AT RAIL			8b9	8	30'-0	641		8	30'-0	641		8	30'-0	641		8	30'-0	641	
SLAB TRANSVERSE, BOTTOM			6c1	67	32'-10	3305		67	34'-0	3422		54	32'-10	2664		40	32'-10	1973	
SLAB TRANSVERSE ENDS, BOTTOM			6c2	-	-	-		-	-	-		30	VARIES	797		56	VARIES	1486	
SLAB TRANSVERSE, TOP			5d1	67	32'-10	2295		67	34'-0	2376		54	32'-10	1850		40	32'-10	1370	
SLAB TRANSVERSE ENDS, TOP			5d2	-	-	-		-	-	-		30	VARIES	553		56	VARIES	1032	
SLAB, TRANSVERSE AT ABUTMENT			8e1	18	32'-10	1578		-	-	-		-	-	-		-	-	-	
SLAB, TRANSVERSE AT ABUTMENT			8e2	-	-	-		18	33'-11	1631		18	37'-6	1803		18	45'-4	2179	
SLAB, HAIRPINS, AT ABUTMENT			6e3	72	5'-0	541		72	5'-1	550		72	5'-5	586		72	6'-1	658	
SLAB, DIAGONALS, AT ABUTMENT			6e4	72	5'-11	640		72	5'-11	640		72	5'-11	640		72	5'-11	640	
PIER CAP HOOPS			5h1	48	6'-11	347		48	6'-11	347		60	6'-11	433		72	6'-11	520	
PIER CAP ENDS			8h2	4	14'-5	154		4	14'-5	154		4	14'-5	154		4	14'-5	154	
PIER CAP, BOTTOM LONGITUDINAL			8h3	8	29'-10	638		8	30'-11	661		8	34'-5	736		8	42'-2	901	
PIER CAP, TOP LONGITUDINAL			8h4	4	32'-10	351		4	34'-0	364		4	37'-11	405		4	46'-6	497	
TOP OF SLAB, TRANSVERSE, AT RAIL			5j1	132	8'-6	1171		132	8'-6	1171		132	8'-6	1171		130	8'-6	1153	
WING, VERTICAL			5m1	40	4'-5	185		40	4'-5	185		40	4'-5	185		40	4'-5	185	
WING, HORIZONTAL BACK FACE			5n1	24	6'-8	167		24	6'-8	167		24	6'-8	167		24	6'-8	167	
WING, HORIZONTAL TRAFFIC FACE			5n3	24	6'-9	169		24	6'-9	169		24	6'-9	169		24	6'-9	169	
** PAVING BLOCK LIFTING HOOPS			5z1	10	2'-10	30		10	2'-10	30		10	2'-10	30		10	2'-10	30	
SUB TOTAL - LBS.						32,327				32,623				33,099				33,870	
BARRIER RAIL - SEE LIST ON RAIL SHEET J30-41-06						4957				4957				4957				4957	
OPEN RAIL - SEE LIST ON RAIL SHEET J30-44-06						5100				5100				5100				5100	
TOTAL - LBS.						37,284				37,580				38,056				38,827	
WITH MONOLITHIC PIER CAP						37,427				37,723				38,199				38,970	
TOTAL - LBS.						35,794				36,054				36,328				36,755	
WITH NON-MONOLITHIC PIER CAP						35,937				36,197				36,471				36,898	
SAME AS ABOVE EXCEPT ALL "h" BARS DELETED						35,937				36,197				36,471				36,898	

** BARS MAY BE NON-COATED AT CONTRACTOR'S OPTION.

ESTIMATED QUANTITIES FOR SUPERSTRUCTURE - 70' BRIDGE

ITEM	SKEW	WITH MONOLITHIC PIER CAP				WITH NON-MONOLITHIC PIER CAP			
		0°	15°	30°	45°	0°	15°	30°	45°
WITH BARRIER RAIL	*STRUCTURAL CONCRETE (BRIDGE) C.Y.	131.2	132.0	134.9	141.0	126.6	127.3	129.6	134.6
CONCRETE BARRIER OR OPEN RAIL	LIN. FT.	162.0	162.2	162.9	164.5	162.0	162.2	162.9	164.5
WITH OPEN RAIL	*STRUCTURAL CONCRETE (BRIDGE) C.Y.	131.1	131.9	134.8	140.8	125.5	127.1	129.5	134.5
REINFORCING STEEL EPOXY COATED	LBS.	37,427	37,723	38,199	38,970	35,937	36,197	36,471	36,898

* INCLUDES 4 WINGS @ 0.68 C.Y. EACH AND 2 TEMPORARY PAVING BLOCKS; EXCLUDES RAIL CONCRETE.

BENT BAR DETAILS

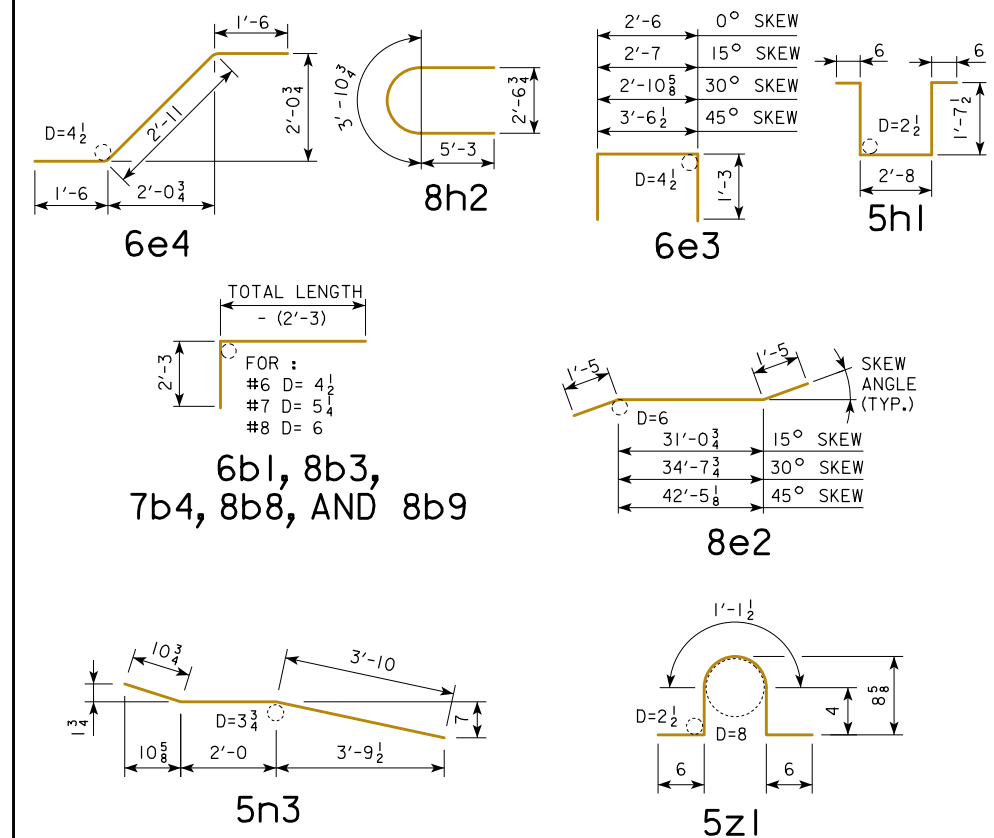

REVISED 07-2009: OPEN RAIL REINF. QTY'S. CHANGED WHICH CHANGED TOTAL REINF. QTY'S. REVISED 09-2020: UPDATED BRIDGE ENGINEER SIGNATURE. CHANGED PAVING BLOCK LIFTING HOOP BAR MARK, (WAS 5x1).

09-2020 LATEST REVISION DATE APPROVED BY BRIDGE ENGINEER	 STANDARD DESIGN - 30' ROADWAY, 3 SPAN BRIDGES CONTINUOUS CONCRETE SLAB BRIDGES NOVEMBER, 2006
	SUPERSTRUCTURE DETAILS 70'-0 BRIDGE
	EPOXY COATED REINFORCING

J30-03E-06

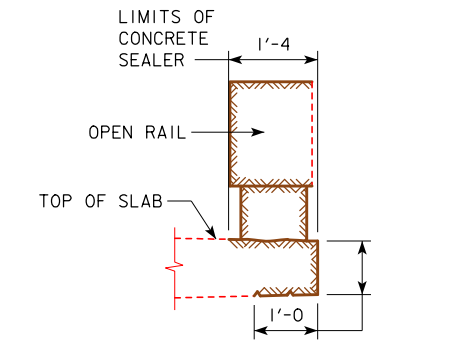
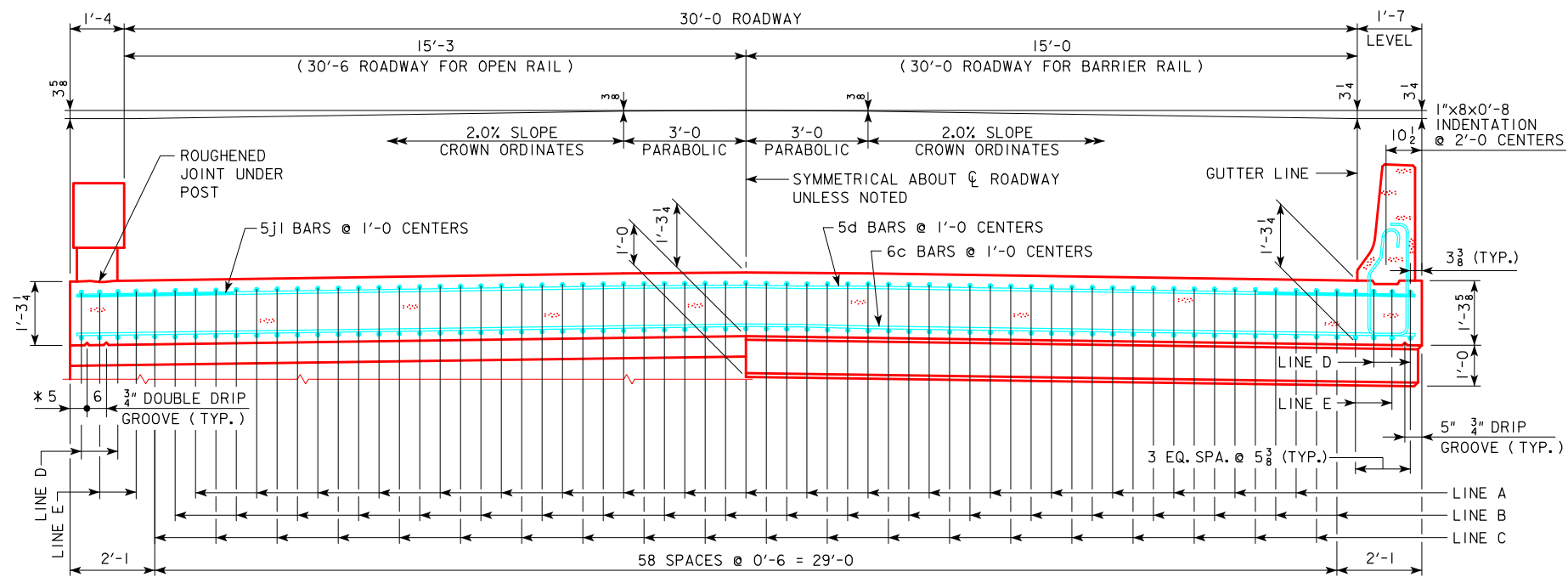

CONCRETE SEALER LIMITS FOR OPEN RAILS

CONCRETE SEALER SHALL BE APPLIED TO BOTH SIDES OF BRIDGE SLAB ON THE TOP, EDGE OF SLAB AND UNDER THE SLAB. THE CONCRETE SEALER SHALL ALSO BE APPLIED TO THE OPEN RAIL ON THE TOP, TRAFFIC FACE SIDE, BOTTOM OF RAIL, AND ON ALL SIDES OF THE OPEN RAIL POSTS.

THE CONCRETE SEALER LIMITS ARE SHOWN IN THE DETAIL AND SHALL APPLY TO THE FULL LENGTH OF BRIDGE. CONCRETE SEALER SHALL BE APPLIED IN ACCORDANCE WITH ARTICLE 2403.03, P, 3 OF THE STANDARD SPECIFICATIONS.

HALF SECTION NEAR ABUTMENT

HALF SECTION NEAR PIER

* NOTE: DOUBLE DRIP GROOVES FOR OPEN RAIL OPTION ONLY.

SLAB CROSS-SECTIONAL AREA FOR OPEN RAIL = 42.15 SQ. FT.

NOTE: TOP LONGITUDINAL REINFORCING STEEL IS TO BE PARALLEL TO AND 2 1/2" CLEAR BELOW TOP OF SLAB. BOTTOM LONGITUDINAL REINFORCING STEEL IS TO BE PARALLEL TO AND 1 1/2" CLEAR ABOVE BOTTOM OF SLAB. REINFORCING STEEL IS TO BE SECURELY WIRED IN PLACE AND ADEQUATELY SUPPORTED ON BAR CHAIRS BEFORE CONCRETE IS POURED. I.M. 451.01 REQUIREMENTS SHALL APPLY FOR BAR CHAIRS.

SLAB CROSS-SECTIONAL AREA FOR BARRIER RAIL = 42.20 SQ. FT.

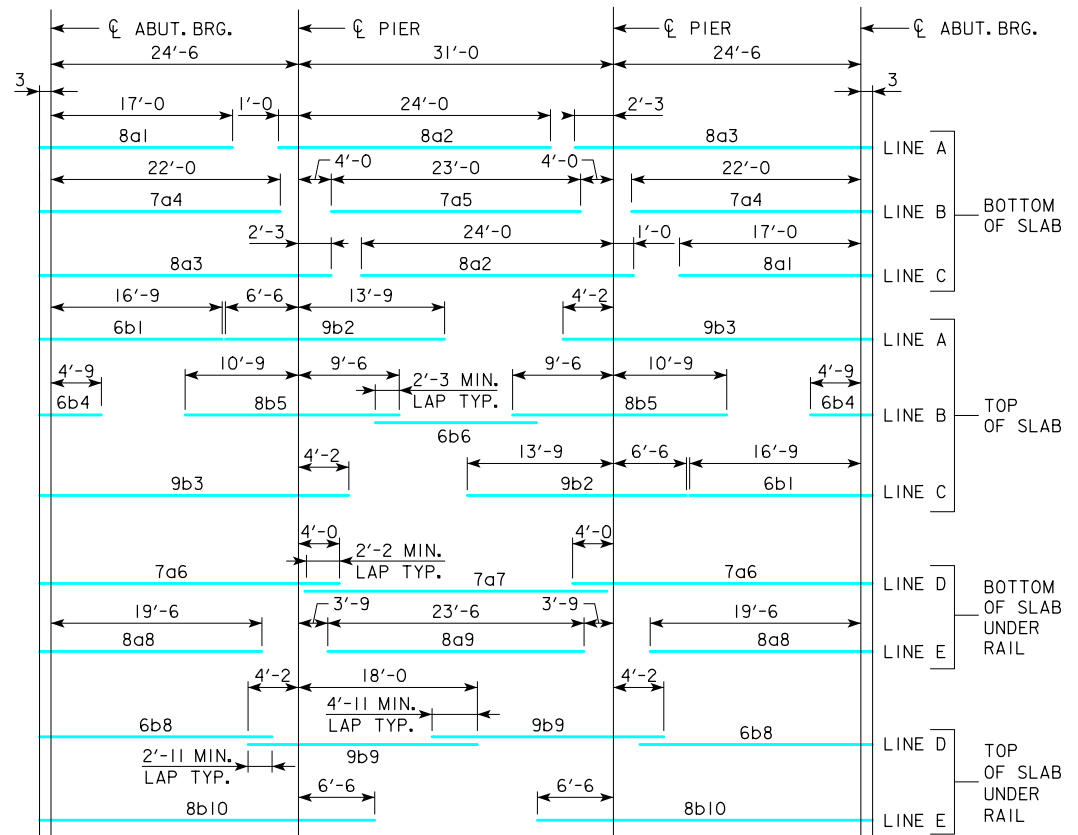

PLACEMENT FOR LONGITUDINAL REINFORCEMENT

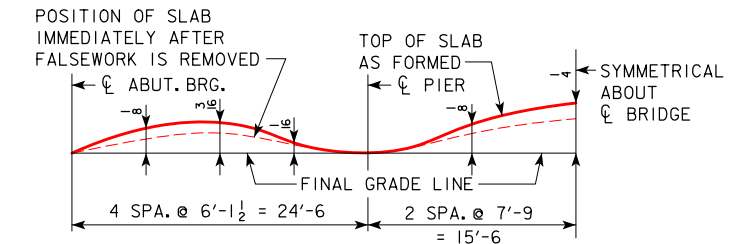

FORM CAMBER DIAGRAM

THIS DIAGRAM SHOWS THE FORM CAMBER REQUIRED TO COMPENSATE FOR THE ANTICIPATED ULTIMATE DEAD LOAD DEFLECTION. THE ABOVE DIMENSIONS DO NOT INCLUDE ANY ALLOWANCE FOR FORM DEFLECTION OR FALSEWORK SETTLEMENT.

REVISED 07-2016; DATE ON SHEET CHANGED TO CORRECT CLERICAL ERROR.
 REVISED 09-2020; UPDATED BRIDGE ENGINEER SIGNATURE.

09-2020 LATEST REVISION DATE	APPROVED BY BRIDGE ENGINEER <i>[Signature]</i>		
		STANDARD DESIGN - 30' ROADWAY, 3 SPAN BRIDGES CONTINUOUS CONCRETE SLAB BRIDGES NOVEMBER, 2006	
		SUPERSTRUCTURE DETAILS 80'-0" BRIDGE	J30-04B-06

NON-EPOXY COATED REINFORCING

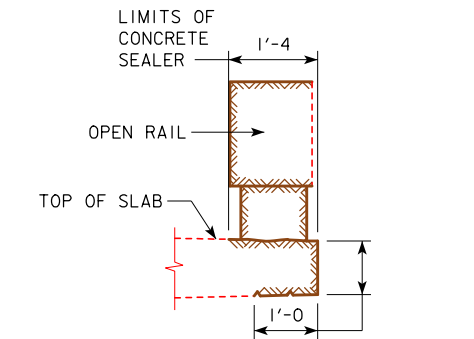
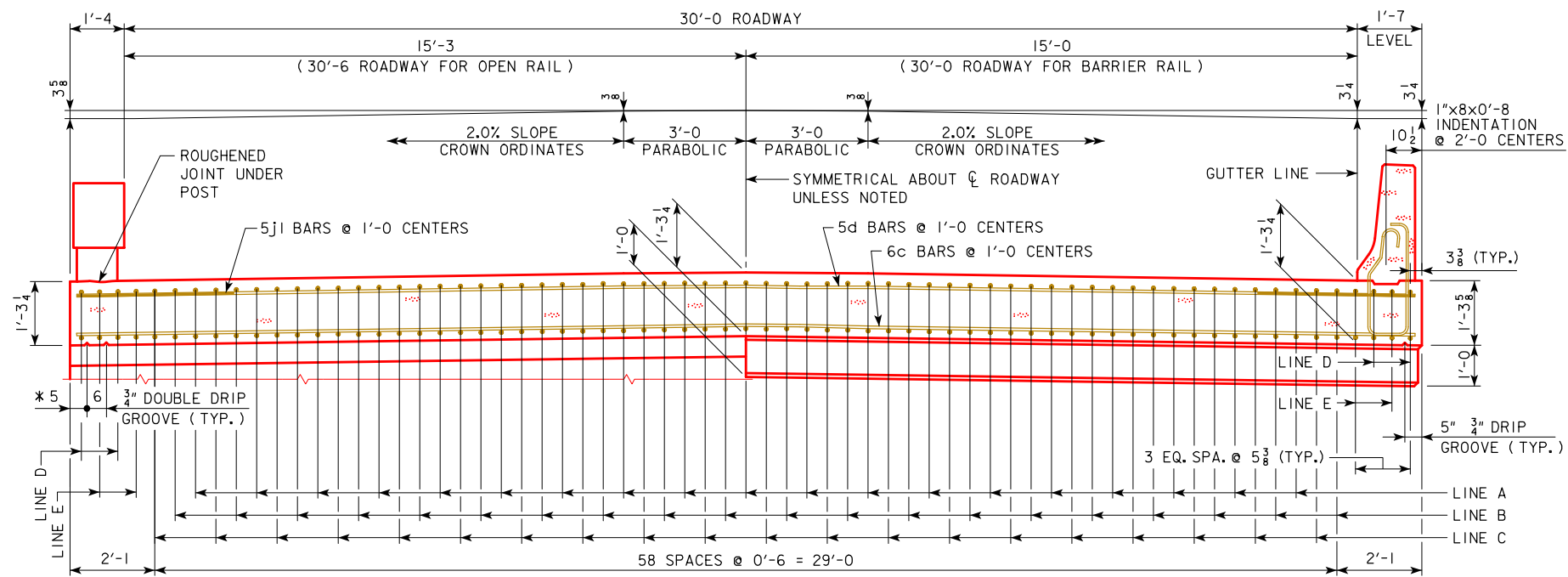

CONCRETE SEALER LIMITS FOR OPEN RAILS

CONCRETE SEALER SHALL BE APPLIED TO BOTH SIDES OF BRIDGE SLAB ON THE TOP, EDGE OF SLAB AND UNDER THE SLAB. THE CONCRETE SEALER SHALL ALSO BE APPLIED TO THE OPEN RAIL ON THE TOP, TRAFFIC FACE SIDE, BOTTOM OF RAIL, AND ON ALL SIDES OF THE OPEN RAIL POSTS.

THE CONCRETE SEALER LIMITS ARE SHOWN IN THE DETAIL AND SHALL APPLY TO THE FULL LENGTH OF BRIDGE. CONCRETE SEALER SHALL BE APPLIED IN ACCORDANCE WITH ARTICLE 2403.03, P, 3 OF THE STANDARD SPECIFICATIONS.

HALF SECTION NEAR ABUTMENT

HALF SECTION NEAR PIER

* NOTE: DOUBLE DRIP GROOVES FOR OPEN RAIL OPTION ONLY.

SLAB CROSS-SECTIONAL AREA FOR OPEN RAIL = 42.15 SQ. FT.

NOTE: TOP LONGITUDINAL REINFORCING STEEL IS TO BE PARALLEL TO AND 2 1/2" CLEAR BELOW TOP OF SLAB. BOTTOM LONGITUDINAL REINFORCING STEEL IS TO BE PARALLEL TO AND 1 1/2" CLEAR ABOVE BOTTOM OF SLAB. REINFORCING STEEL IS TO BE SECURELY WIRED IN PLACE AND ADEQUATELY SUPPORTED ON BAR CHAIRS BEFORE CONCRETE IS POURED. I.M. 451.01 REQUIREMENTS SHALL APPLY FOR BAR CHAIRS.

SLAB CROSS-SECTIONAL AREA FOR BARRIER RAIL = 42.20 SQ. FT.

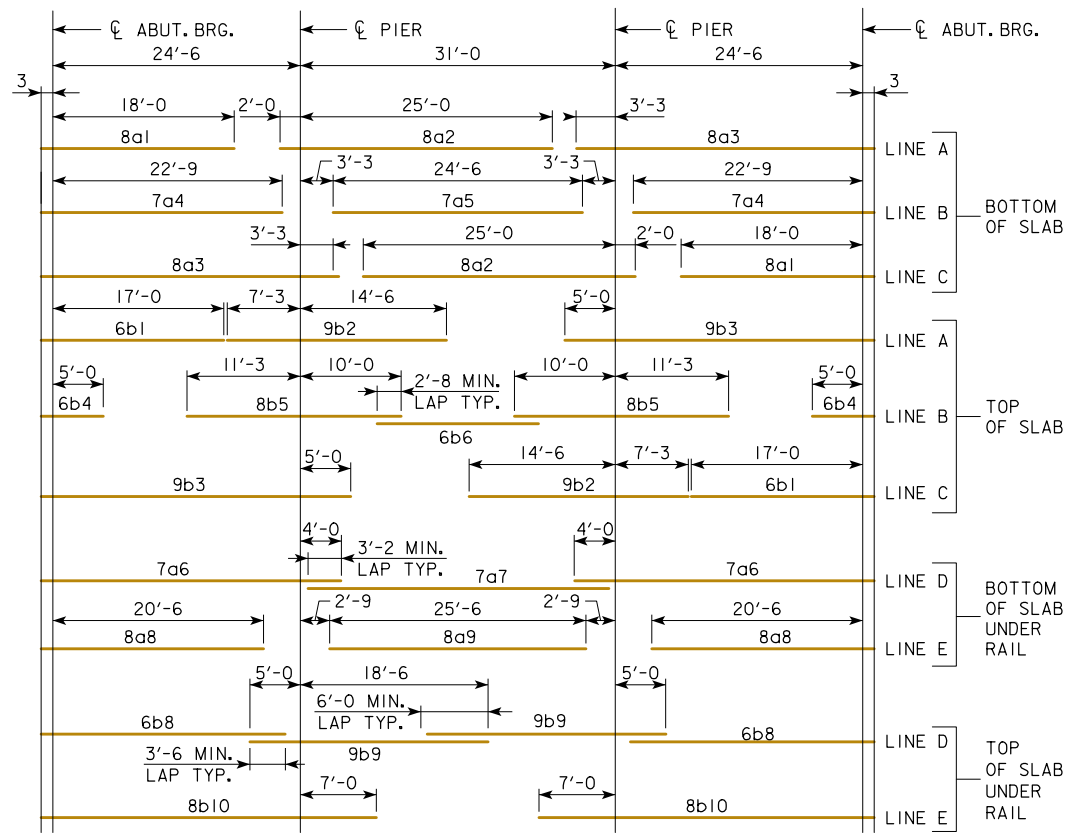

PLACEMENT FOR LONGITUDINAL REINFORCEMENT

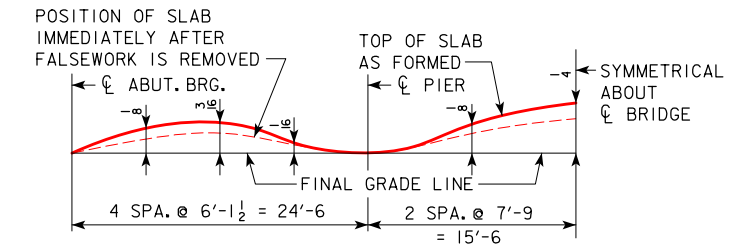

FORM CAMBER DIAGRAM

THIS DIAGRAM SHOWS THE FORM CAMBER REQUIRED TO COMPENSATE FOR THE ANTICIPATED ULTIMATE DEAD LOAD DEFLECTION. THE ABOVE DIMENSIONS DO NOT INCLUDE ANY ALLOWANCE FOR FORM DEFLECTION OR FALSEWORK SETTLEMENT.

REVISED 07-2016; DATE ON SHEET CHANGED TO CORRECT CLERICAL ERROR. REVISED 09-2020; UPDATED BRIDGE ENGINEER SIGNATURE.

09-2020 LATEST REVISION DATE APPROVED BY BRIDGE ENGINEER	 STANDARD DESIGN - 30' ROADWAY, 3 SPAN BRIDGES CONTINUOUS CONCRETE SLAB BRIDGES NOVEMBER, 2006	
	SUPERSTRUCTURE DETAILS 80'-0" BRIDGE EPOXY COATED REINFORCING	J30-04E-06

REVISED 07-2009; OPEN RAIL REINF. QTY'S. CHANGED WHICH CHANGED TOTAL REINF. QTY'S.
REVISED 09-2020; UPDATED BRIDGE ENGINEER SIGNATURE. CHANGED PAVING BLOCK LIFTING HOOP BAR MARK, (WAS 5x1).

BILL OF REINFORCING STEEL FOR SUPERSTRUCTURE - 80' BRIDGE

LOCATION	SKEW	SHAPE	BAR	0°				15°				30°				45°			
				NO.	LENGTH	WEIGHT		NO.	LENGTH	WEIGHT		NO.	LENGTH	WEIGHT		NO.	LENGTH	WEIGHT	
SLAB LONGITUDINAL BOTTOM			8a1	39	17'-3	1797		39	17'-3	1797		39	17'-3	1797		39	17'-3	1797	
SLAB LONGITUDINAL BOTTOM			8a2	39	25'-0	2604		39	25'-0	2604		39	25'-0	2604		39	25'-0	2604	
SLAB LONGITUDINAL BOTTOM			8a3	39	27'-0	2812		39	27'-0	2812		39	27'-0	2812		39	27'-0	2812	
SLAB LONGITUDINAL BOTTOM			7a4	40	22'-3	1820		40	22'-3	1820		40	22'-3	1820		40	22'-3	1820	
SLAB LONGITUDINAL BOTTOM			7a5	20	23'-0	941		20	23'-0	941		20	23'-0	941		20	23'-0	941	
SLAB LONGITUDINAL BOTTOM, AT RAIL			7a6	8	28'-9	471		8	28'-9	471		8	28'-9	471		8	28'-9	471	
SLAB LONGITUDINAL BOTTOM, AT RAIL			7a7	4	27'-4	224		4	27'-4	224		4	27'-4	224		4	27'-4	224	
SLAB LONGITUDINAL BOTTOM, AT RAIL			8a8	8	19'-9	422		8	19'-9	422		8	19'-9	422		8	19'-9	422	
SLAB LONGITUDINAL BOTTOM, AT RAIL			8a9	4	23'-6	251		4	23'-6	251		4	23'-6	251		4	23'-6	251	
SLAB LONGITUDINAL TOP			6b1	39	19'-3	1128		39	19'-3	1128		39	19'-3	1128		39	19'-3	1128	
SLAB LONGITUDINAL TOP			9b2	39	20'-3	2686		39	20'-3	2686		39	20'-3	2686		39	20'-3	2686	
SLAB LONGITUDINAL TOP			9b3	39	31'-2	4133		39	31'-2	4133		39	31'-2	4133		39	31'-2	4133	
SLAB LONGITUDINAL TOP			6b4	40	7'-3	436		40	7'-3	436		40	7'-3	436		40	7'-3	436	
SLAB LONGITUDINAL TOP			8b5	40	20'-3	2163		40	20'-3	2163		40	20'-3	2163		40	20'-3	2163	
SLAB LONGITUDINAL TOP			6b6	20	16'-6	496		20	16'-6	496		20	16'-6	496		20	16'-6	496	
SLAB LONGITUDINAL TOP, AT RAIL			6b8	8	25'-9	310		8	25'-9	310		8	25'-9	310		8	25'-9	310	
SLAB LONGITUDINAL TOP, AT RAIL			9b9	8	22'-2	603		8	22'-2	603		8	22'-2	603		8	22'-2	603	
SLAB LONGITUDINAL TOP, AT RAIL			8b10	8	33'-6	716		8	33'-6	716		8	33'-6	716		8	33'-6	716	
SLAB TRANSVERSE, BOTTOM			6c1	77	32'-10	3798		77	34'-0	3933		64	32'-10	3157		50	32'-10	2466	
SLAB TRANSVERSE ENDS, BOTTOM			6c2	-	-	-		-	-	-		30	VARIABLES	797		56	VARIABLES	1486	
SLAB TRANSVERSE, TOP			5d1	77	32'-10	2637		77	34'-0	2731		64	32'-10	2192		50	32'-10	1713	
SLAB TRANSVERSE ENDS, TOP			5d2	-	-	-		-	-	-		30	VARIABLES	553		56	VARIABLES	1032	
SLAB, TRANSVERSE AT ABUTMENT			8e1	18	32'-10	1578		-	-	-		-	-	-		-	-	-	
SLAB, TRANSVERSE AT ABUTMENT			8e2	-	-	-		18	33'-11	1631		18	37'-6	1803		18	45'-4	2179	
SLAB, HAIRPINS, AT ABUTMENT			6e3	72	5'-0	541		72	5'-1	550		72	5'-5	586		72	6'-1	658	
SLAB, DIAGONALS, AT ABUTMENT			6e4	72	5'-11	640		72	5'-11	640		72	5'-11	640		72	5'-11	640	
PIER CAP HOOPS			5h1	48	7'-1	355		48	7'-1	355		60	7'-1	444		72	7'-1	532	
PIER CAP ENDS			8h2	4	14'-5	154		4	14'-5	154		4	14'-5	154		4	14'-5	154	
PIER CAP, BOTTOM LONGITUDINAL			8h3	8	29'-10	638		8	30'-11	661		8	34'-5	736		8	42'-2	901	
PIER CAP, TOP LONGITUDINAL			8h4	4	32'-10	351		4	34'-0	364		4	37'-11	405		4	46'-6	497	
TOP OF SLAB, TRANSVERSE, AT RAIL			5j1	152	8'-6	1348		152	8'-6	1348		152	8'-6	1348		150	8'-6	1330	
WING, VERTICAL			5m1	40	4'-5	185		40	4'-5	185		40	4'-5	185		40	4'-5	185	
WING, HORIZONTAL BACK FACE			5n1	24	6'-8	167		24	6'-8	167		24	6'-8	167		24	6'-8	167	
WING, HORIZONTAL TRAFFIC FACE			5n3	24	6'-9	169		24	6'-9	169		24	6'-9	169		24	6'-9	169	
PAVING BLOCK LIFTING HOOPS			5z1	10	2'-10	30		10	2'-10	30		10	2'-10	30		10	2'-10	30	
SUB TOTAL - LBS.						36,604				36,931				37,379				38,152	
BARRIER RAIL - SEE LIST ON RAIL SHEET J30-41-06						5464				5464				5464				5464	
OPEN RAIL - SEE LIST ON RAIL SHEET J30-44-06						5799				5799				5799				5799	
TOTAL - LBS.				WITH MONOLITHIC PIER CAP	WITH BARRIER RAIL	42,068				42,395				42,843				43,616	
				WITH OPEN RAIL		42,403				42,730				43,178				43,951	
TOTAL - LBS.				WITH NON-MONOLITHIC PIER CAP	WITH BARRIER RAIL	40,570				40,861				41,104				41,532	
SAME AS ABOVE EXCEPT ALL "h" BARS DELETED				WITH OPEN RAIL		40,905				41,196				41,439				41,867	

ESTIMATED QUANTITIES FOR SUPERSTRUCTURE - 80' BRIDGE

ITEM	SKEW	WITH MONOLITHIC PIER CAP				WITH NON-MONOLITHIC PIER CAP			
		0°	15°	30°	45°	0°	15°	30°	45°
WITH REINFORCING STEEL	*STRUCTURAL CONCRETE (BRIDGE) C.Y.	152.0	152.8	155.6	161.6	147.4	148.0	150.4	155.3
BARRIER RAIL	LBS.	42,068	42,395	42,843	43,616	40,570	40,861	41,104	41,532
CONCRETE BARRIER OR OPEN RAIL	LIN. FT.	182.0	182.2	182.9	184.5	182.0	182.2	182.9	184.5
WITH REINFORCING STEEL	*STRUCTURAL CONCRETE (BRIDGE) C.Y.	151.8	152.6	155.5	161.5	147.2	147.9	150.2	155.1
OPEN RAIL	LBS.	42,403	42,730	43,178	43,951	40,905	41,196	41,439	41,867

* INCLUDES 4 WINGS @ 0.68 C.Y. EACH AND 2 TEMPORARY PAVING BLOCKS; EXCLUDES RAIL CONCRETE.

BENT BAR DETAILS

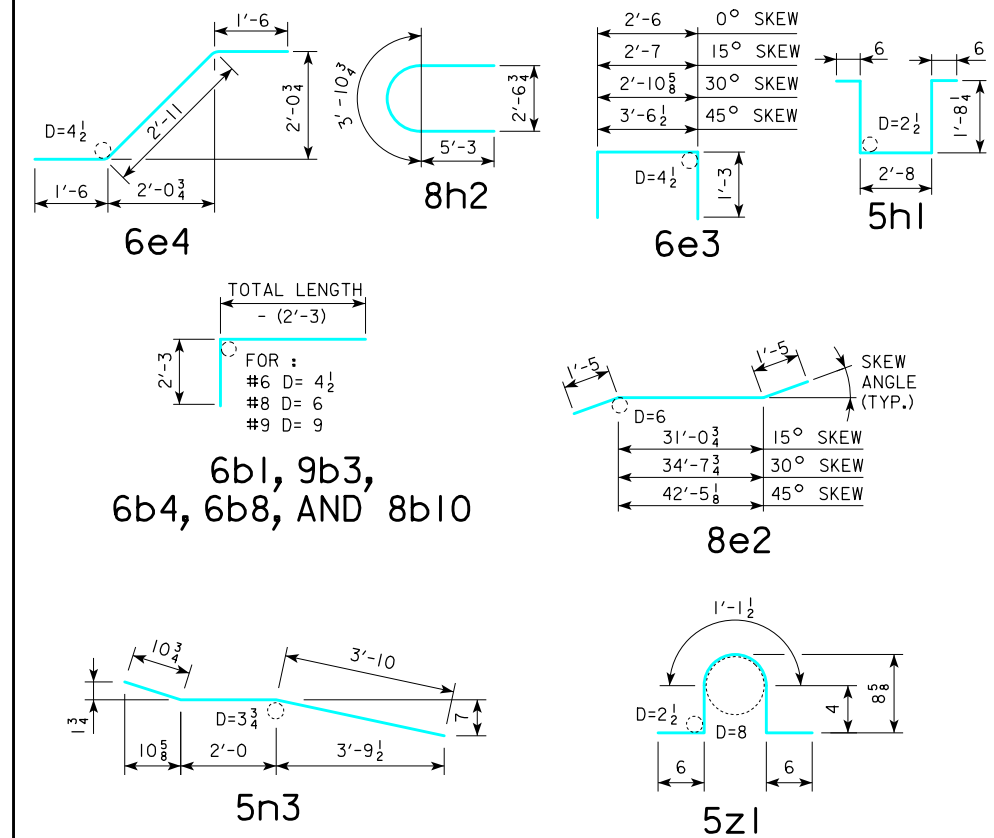

NOTE: ALL DIMENSIONS ARE OUT TO OUT. D = PIN DIAMETER.

09-2020
LATEST REVISION DATE

[Signature]
APPROVED BY BRIDGE ENGINEER

STANDARD DESIGN - 30' ROADWAY, 3 SPAN BRIDGES

CONTINUOUS CONCRETE SLAB BRIDGES

NOVEMBER, 2006

J30-05B-06

SUPERSTRUCTURE DETAILS
80'-0 BRIDGE

NON-EPOXY COATED REINFORCING

BILL OF REINFORCING STEEL FOR SUPERSTRUCTURE - 80' BRIDGE

LOCATION	SKEW	SHAPE	0°				15°				30°				45°			
			NO.	LENGTH	WEIGHT		NO.	LENGTH	WEIGHT		NO.	LENGTH	WEIGHT		NO.	LENGTH	WEIGHT	
SLAB LONGITUDINAL BOTTOM		8a1	39	18'-3	1901	39	18'-3	1901	39	18'-3	1901	39	18'-3	1901				
SLAB LONGITUDINAL BOTTOM		8a2	39	27'-0	2812	39	27'-0	2812	39	27'-0	2812	39	27'-0	2812				
SLAB LONGITUDINAL BOTTOM		8a3	39	28'-0	2916	39	28'-0	2916	39	28'-0	2916	39	28'-0	2916				
SLAB LONGITUDINAL BOTTOM		7a4	40	23'-0	1881	40	23'-0	1881	40	23'-0	1881	40	23'-0	1881				
SLAB LONGITUDINAL BOTTOM		7a5	20	24'-6	1002	20	24'-6	1002	20	24'-6	1002	20	24'-6	1002				
SLAB LONGITUDINAL BOTTOM, AT RAIL		7a6	8	28'-9	471	8	28'-9	471	8	28'-9	471	8	28'-9	471				
SLAB LONGITUDINAL BOTTOM, AT RAIL		7a7	4	29'-4	240	4	29'-4	240	4	29'-4	240	4	29'-4	240				
SLAB LONGITUDINAL BOTTOM, AT RAIL		8a8	8	20'-9	444	8	20'-9	444	8	20'-9	444	8	20'-9	444				
SLAB LONGITUDINAL BOTTOM, AT RAIL		8a9	4	25'-6	273	4	25'-6	273	4	25'-6	273	4	25'-6	273				
SLAB LONGITUDINAL TOP		6b1	39	19'-6	1143	39	19'-6	1143	39	19'-6	1143	39	19'-6	1143				
SLAB LONGITUDINAL TOP		9b2	39	21'-9	2885	39	21'-9	2885	39	21'-9	2885	39	21'-9	2885				
SLAB LONGITUDINAL TOP		9b3	39	32'-0	4244	39	32'-0	4244	39	32'-0	4244	39	32'-0	4244				
SLAB LONGITUDINAL TOP		6b4	40	7'-6	451	40	7'-6	451	40	7'-6	451	40	7'-6	451				
SLAB LONGITUDINAL TOP		8b5	40	21'-3	2270	40	21'-3	2270	40	21'-3	2270	40	21'-3	2270				
SLAB LONGITUDINAL TOP		6b6	20	16'-4	491	20	16'-4	491	20	16'-4	491	20	16'-4	491				
SLAB LONGITUDINAL TOP, AT RAIL		6b8	8	25'-6	307	8	25'-6	307	8	25'-6	307	8	25'-6	307				
SLAB LONGITUDINAL TOP, AT RAIL		9b9	8	23'-6	640	8	23'-6	640	8	23'-6	640	8	23'-6	640				
SLAB LONGITUDINAL TOP, AT RAIL		8b10	8	34'-0	727	8	34'-0	727	8	34'-0	727	8	34'-0	727				
SLAB TRANSVERSE, BOTTOM		6c1	77	32'-10	3798	77	34'-0	3933	64	32'-10	3157	50	32'-10	2466				
SLAB TRANSVERSE ENDS, BOTTOM		6c2	-	-	-	-	-	-	30	VARIABLES	797	56	VARIABLES	1486				
SLAB TRANSVERSE, TOP		5d1	77	32'-10	2637	77	34'-0	2731	64	32'-10	2192	50	32'-10	1713				
SLAB TRANSVERSE ENDS, TOP		5d2	-	-	-	-	-	-	30	VARIABLES	553	56	VARIABLES	1032				
SLAB, TRANSVERSE AT ABUTMENT		8e1	18	32'-10	1578	-	-	-	-	-	-	-	-	-				
SLAB, TRANSVERSE AT ABUTMENT		8e2	-	-	-	18	33'-11	1631	18	37'-6	1803	18	45'-4	2179				
SLAB, HAIRPINS, AT ABUTMENT		6e3	72	5'-0	541	72	5'-1	550	72	5'-5	586	72	6'-1	658				
SLAB, DIAGONALS, AT ABUTMENT		6e4	72	5'-11	640	72	5'-11	640	72	5'-11	640	72	5'-11	640				
PIER CAP HOOPS		5h1	48	7'-1	355	48	7'-1	355	60	7'-1	444	72	7'-1	532				
PIER CAP ENDS		8h2	4	14'-5	154	4	14'-5	154	4	14'-5	154	4	14'-5	154				
PIER CAP, BOTTOM LONGITUDINAL		8h3	8	29'-10	638	8	30'-11	661	8	34'-5	736	8	42'-2	901				
PIER CAP, TOP LONGITUDINAL		8h4	4	32'-10	351	4	34'-0	364	4	37'-11	405	4	46'-6	497				
TOP OF SLAB, TRANSVERSE, AT RAIL		5j1	152	8'-6	1348	152	8'-6	1348	152	8'-6	1348	150	8'-6	1330				
WING, VERTICAL		5m1	40	4'-5	185	40	4'-5	185	40	4'-5	185	40	4'-5	185				
WING, HORIZONTAL BACK FACE		5n1	24	6'-8	167	24	6'-8	167	24	6'-8	167	24	6'-8	167				
WING, HORIZONTAL TRAFFIC FACE		5n3	24	6'-9	169	24	6'-9	169	24	6'-9	169	24	6'-9	169				
** PAVING BLOCK LIFTING HOOPS		5z1	10	2'-10	30	10	2'-10	30	10	2'-10	30	10	2'-10	30				
SUB TOTAL - LBS.					37,689			38,016			38,464			39,237				
BARRIER RAIL - SEE LIST ON RAIL SHEET J30-41-06					5464			5464			5464			5464				
OPEN RAIL - SEE LIST ON RAIL SHEET J30-44-06					5799			5799			5799			5799				
TOTAL - LBS.			WITH MONOLITHIC PIER CAP	WITH BARRIER RAIL	43,153			43,480			43,928			44,701				
				WITH OPEN RAIL	43,488			43,815			44,263			45,036				
TOTAL - LBS.			WITH NON-MONOLITHIC PIER CAP	WITH BARRIER RAIL	41,655			41,946			42,189			42,617				
SAME AS ABOVE EXCEPT ALL "h" BARS DELETED				WITH OPEN RAIL	41,990			42,281			42,524			42,952				

** BARS MAY BE NON-COATED AT CONTRACTOR'S OPTION.

ESTIMATED QUANTITIES FOR SUPERSTRUCTURE - 80' BRIDGE

ITEM	SKEW	WITH MONOLITHIC PIER CAP				WITH NON-MONOLITHIC PIER CAP			
		0°	15°	30°	45°	0°	15°	30°	45°
WITH *STRUCTURAL CONCRETE (BRIDGE) C.Y.		152.0	152.8	155.6	161.6	147.4	148.0	150.4	155.3
BARRIER RAIL REINFORCING STEEL EPOXY COATED LBS.		43,153	43,480	43,928	44,701	41,655	41,946	42,189	42,617
CONCRETE BARRIER OR OPEN RAIL LIN. FT.		182.0	182.2	182.9	184.5	182.0	182.2	182.9	184.5
WITH *STRUCTURAL CONCRETE (BRIDGE) C.Y.		151.8	152.6	155.5	161.5	147.2	147.8	150.2	155.1
OPEN RAIL REINFORCING STEEL EPOXY COATED LBS.		43,488	43,815	44,263	45,036	41,990	42,281	42,524	42,952

* INCLUDES 4 WINGS @ 0.68 C.Y. EACH AND 2 TEMPORARY PAVING BLOCKS; EXCLUDES RAIL CONCRETE.

BENT BAR DETAILS

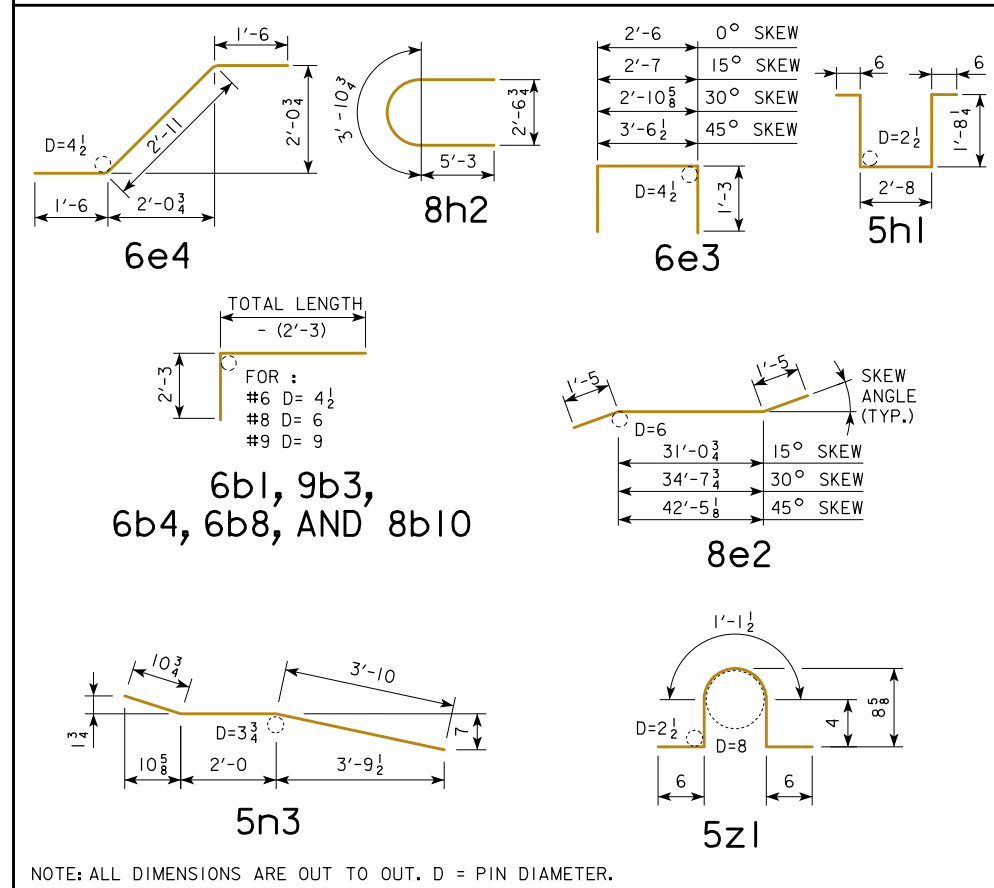

09-2020 LATEST REVISION DATE		APPROVED BY BRIDGE ENGINEER		
			STANDARD DESIGN - 30' ROADWAY, 3 SPAN BRIDGES	
			CONTINUOUS CONCRETE SLAB BRIDGES	
			NOVEMBER, 2006	
SUPERSTRUCTURE DETAILS 80'-0 BRIDGE		J30-05E-06		
EPOXY COATED REINFORCING				

REVISED 07-2009; OPEN RAIL REINF. QTY'S. CHANGED WHICH CHANGED TOTAL REINF. QTY'S.
REVISED 09-2020; UPDATED BRIDGE ENGINEER SIGNATURE. CHANGED PAVING BLOCK LIFTING HOOP BAR MARK, (WAS 5x1).

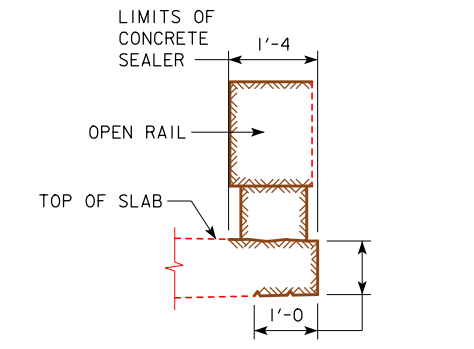
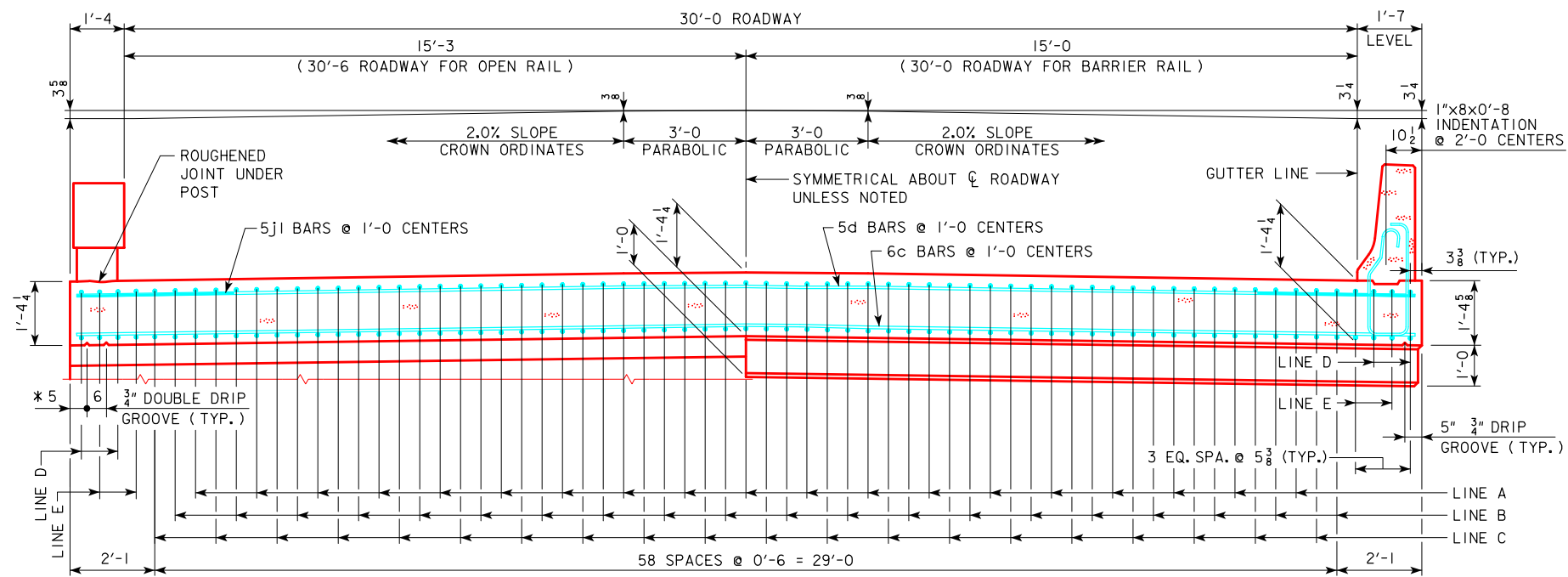

CONCRETE SEALER LIMITS FOR OPEN RAILS

CONCRETE SEALER SHALL BE APPLIED TO BOTH SIDES OF BRIDGE SLAB ON THE TOP, EDGE OF SLAB AND UNDER THE SLAB. THE CONCRETE SEALER SHALL ALSO BE APPLIED TO THE OPEN RAIL ON THE TOP, TRAFFIC FACE SIDE, BOTTOM OF RAIL, AND ON ALL SIDES OF THE OPEN RAIL POSTS.

THE CONCRETE SEALER LIMITS ARE SHOWN IN THE DETAIL AND SHALL APPLY TO THE FULL LENGTH OF BRIDGE. CONCRETE SEALER SHALL BE APPLIED IN ACCORDANCE WITH ARTICLE 2403.03, P, 3 OF THE STANDARD SPECIFICATIONS.

HALF SECTION NEAR ABUTMENT

HALF SECTION NEAR PIER

* NOTE: DOUBLE DRIP GROOVES FOR OPEN RAIL OPTION ONLY.

SLAB CROSS-SECTIONAL AREA FOR OPEN RAIL = 44.92 SQ. FT.

NOTE: TOP LONGITUDINAL REINFORCING STEEL IS TO BE PARALLEL TO AND 2 1/2" CLEAR BELOW TOP OF SLAB. BOTTOM LONGITUDINAL REINFORCING STEEL IS TO BE PARALLEL TO AND 1 1/2" CLEAR ABOVE BOTTOM OF SLAB. REINFORCING STEEL IS TO BE SECURELY WIRED IN PLACE AND ADEQUATELY SUPPORTED ON BAR CHAIRS BEFORE CONCRETE IS POURED. I.M. 451.01 REQUIREMENTS SHALL APPLY FOR BAR CHAIRS.

SLAB CROSS-SECTIONAL AREA FOR BARRIER RAIL = 44.97 SQ. FT.

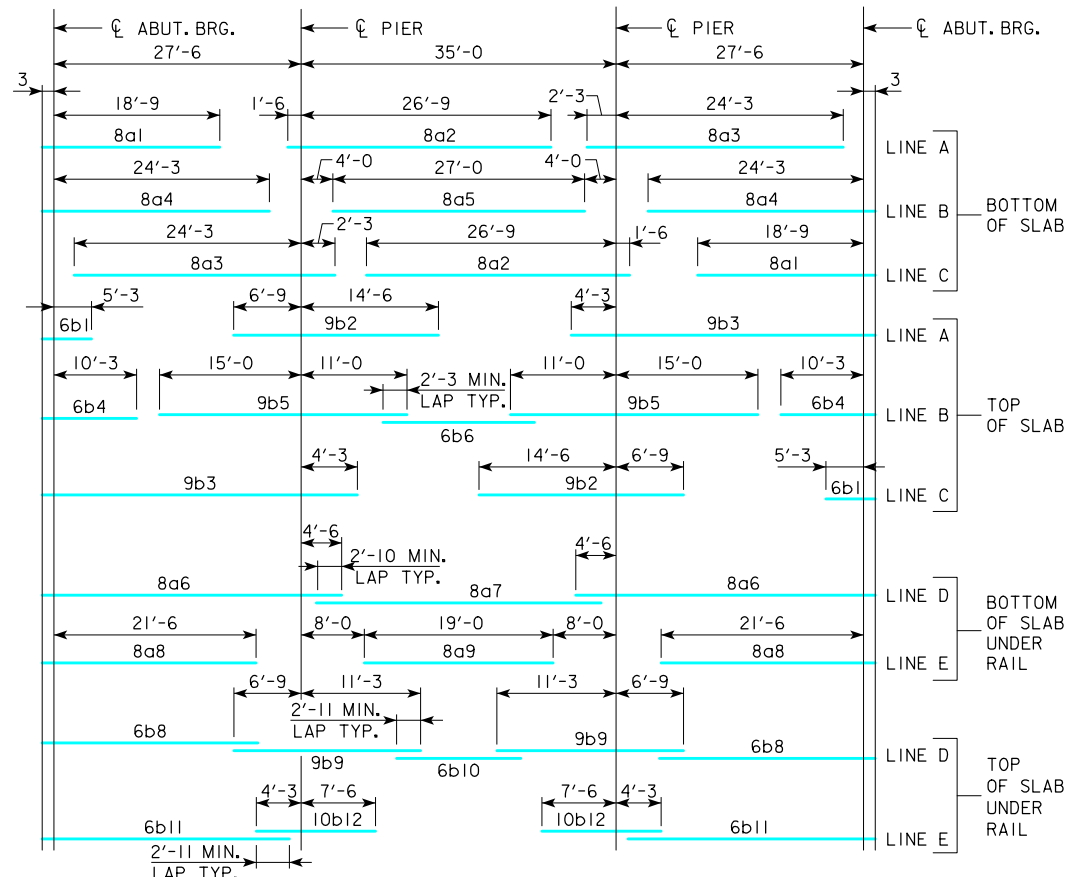

PLACEMENT FOR LONGITUDINAL REINFORCEMENT

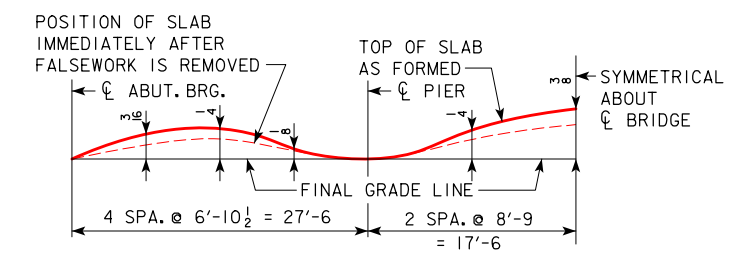

FORM CAMBER DIAGRAM

THIS DIAGRAM SHOWS THE FORM CAMBER REQUIRED TO COMPENSATE FOR THE ANTICIPATED ULTIMATE DEAD LOAD DEFLECTION. THE ABOVE DIMENSIONS DO NOT INCLUDE ANY ALLOWANCE FOR FORM DEFLECTION OR FALSEWORK SETTLEMENT.

REVISED 07-2016; DATE ON SHEET CHANGED TO CORRECT CLERICAL ERROR.
 REVISED 09-2020; UPDATED BRIDGE ENGINEER SIGNATURE.

09-2020 LATEST REVISION DATE	<i>[Signature]</i> APPROVED BY BRIDGE ENGINEER		
		STANDARD DESIGN - 30' ROADWAY, 3 SPAN BRIDGES CONTINUOUS CONCRETE SLAB BRIDGES NOVEMBER, 2006	
		SUPERSTRUCTURE DETAILS 90'-0 BRIDGE NON-EPOXY COATED REINFORCING	J30-06B-06

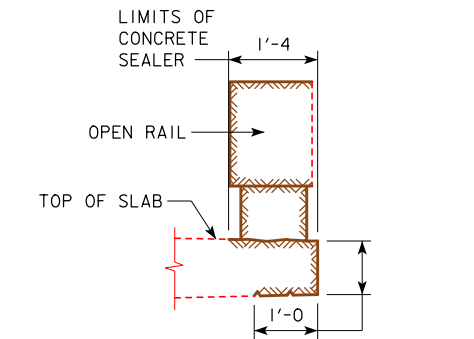
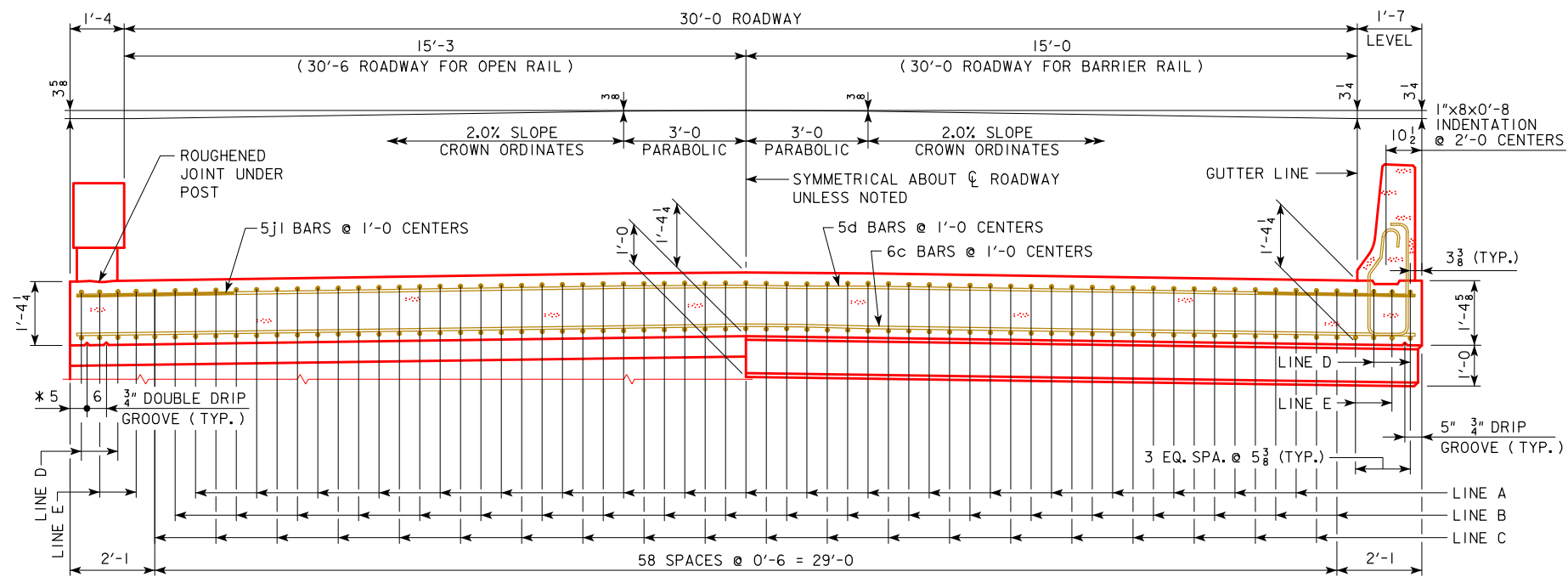

CONCRETE SEALER LIMITS FOR OPEN RAILS

CONCRETE SEALER SHALL BE APPLIED TO BOTH SIDES OF BRIDGE SLAB ON THE TOP, EDGE OF SLAB AND UNDER THE SLAB. THE CONCRETE SEALER SHALL ALSO BE APPLIED TO THE OPEN RAIL ON THE TOP, TRAFFIC FACE SIDE, BOTTOM OF RAIL, AND ON ALL SIDES OF THE OPEN RAIL POSTS.

THE CONCRETE SEALER LIMITS ARE SHOWN IN THE DETAIL AND SHALL APPLY TO THE FULL LENGTH OF BRIDGE. CONCRETE SEALER SHALL BE APPLIED IN ACCORDANCE WITH ARTICLE 2403.03, P, 3 OF THE STANDARD SPECIFICATIONS.

HALF SECTION NEAR ABUTMENT

HALF SECTION NEAR PIER

* NOTE: DOUBLE DRIP GROOVES FOR OPEN RAIL OPTION ONLY.

SLAB CROSS-SECTIONAL AREA FOR OPEN RAIL = 44.92 SQ. FT.

NOTE: TOP LONGITUDINAL REINFORCING STEEL IS TO BE PARALLEL TO AND 2 1/2" CLEAR BELOW TOP OF SLAB. BOTTOM LONGITUDINAL REINFORCING STEEL IS TO BE PARALLEL TO AND 1 1/2" CLEAR ABOVE BOTTOM OF SLAB. REINFORCING STEEL IS TO BE SECURELY WIRED IN PLACE AND ADEQUATELY SUPPORTED ON BAR CHAIRS BEFORE CONCRETE IS POURED. I.M. 451.01 REQUIREMENTS SHALL APPLY FOR BAR CHAIRS.

SLAB CROSS-SECTIONAL AREA FOR BARRIER RAIL = 44.97 SQ. FT.

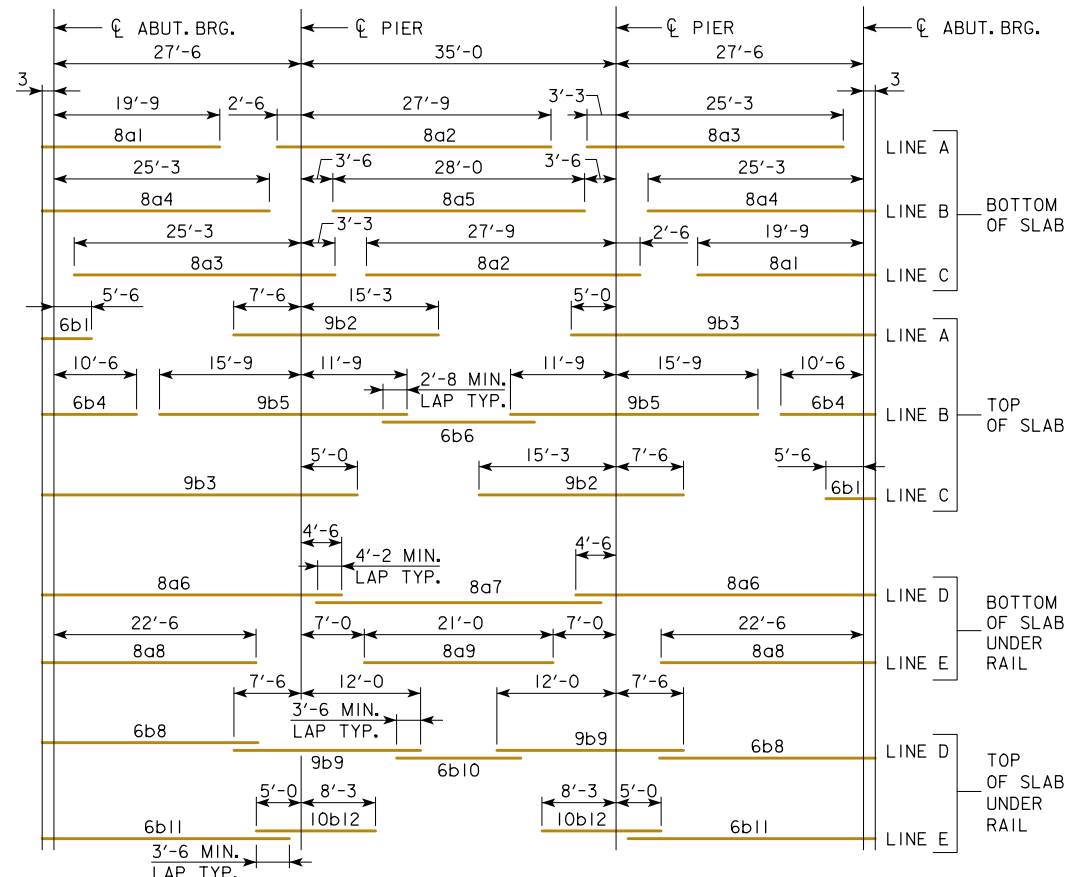

PLACEMENT FOR LONGITUDINAL REINFORCEMENT

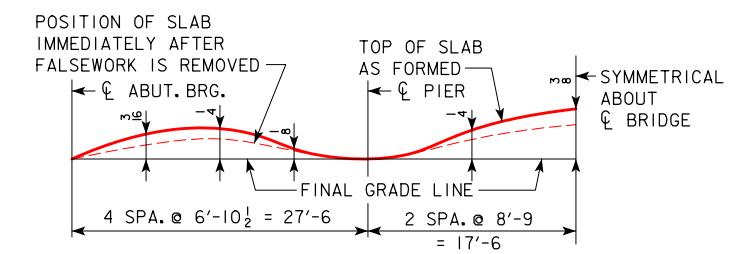

FORM CAMBER DIAGRAM

THIS DIAGRAM SHOWS THE FORM CAMBER REQUIRED TO COMPENSATE FOR THE ANTICIPATED ULTIMATE DEAD LOAD DEFLECTION. THE ABOVE DIMENSIONS DO NOT INCLUDE ANY ALLOWANCE FOR FORM DEFLECTION OR FALSEWORK SETTLEMENT.

REVISED 07-2016; DATE ON SHEET CHANGED TO CORRECT CLERICAL ERROR.
 REVISED 09-2020; UPDATED BRIDGE ENGINEER SIGNATURE.

09-2020 LATEST REVISION DATE	 APPROVED BY BRIDGE ENGINEER		
		STANDARD DESIGN - 30' ROADWAY, 3 SPAN BRIDGES CONTINUOUS CONCRETE SLAB BRIDGES NOVEMBER, 2006	
		SUPERSTRUCTURE DETAILS 90'-0 BRIDGE	J30-06E-06

EPOXY COATED REINFORCING

REVISED 07-2009: OPEN RAIL REINF. QTY'S. CHANGED WHICH CHANGED TOTAL REINF. QTY'S.
REVISED 09-2020: UPDATED BRIDGE ENGINEER SIGNATURE. CHANGED PAVING BLOCK LIFTING HOOP BAR MARK, (WAS 5x1).

BILL OF REINFORCING STEEL FOR SUPERSTRUCTURE - 90' BRIDGE

LOCATION	SKEW	SHAPE	BAR	0°				15°				30°				45°			
				NO.	LENGTH	WEIGHT		NO.	LENGTH	WEIGHT		NO.	LENGTH	WEIGHT		NO.	LENGTH	WEIGHT	
SLAB LONGITUDINAL BOTTOM			8a1	39	19'-0	1979		39	19'-0	1979		39	19'-0	1979		39	19'-0	1979	
SLAB LONGITUDINAL BOTTOM			8a2	39	28'-3	2942		39	28'-3	2942		39	28'-3	2942		39	28'-3	2942	
SLAB LONGITUDINAL BOTTOM			8a3	39	26'-6	2760		39	26'-6	2760		39	26'-6	2760		39	26'-6	2760	
SLAB LONGITUDINAL BOTTOM			8a4	40	24'-6	2617		40	24'-6	2617		40	24'-6	2617		40	24'-6	2617	
SLAB LONGITUDINAL BOTTOM			8a5	20	27'-0	1442		20	27'-0	1442		20	27'-0	1442		20	27'-0	1442	
SLAB LONGITUDINAL BOTTOM, AT RAIL			8a6	8	32'-3	689		8	32'-3	689		8	32'-3	689		8	32'-3	689	
SLAB LONGITUDINAL BOTTOM, AT RAIL			8a7	4	31'-8	339		4	31'-8	339		4	31'-8	339		4	31'-8	339	
SLAB LONGITUDINAL BOTTOM, AT RAIL			8a8	8	21'-9	465		8	21'-9	465		8	21'-9	465		8	21'-9	465	
SLAB LONGITUDINAL BOTTOM, AT RAIL			8a9	4	19'-0	203		4	19'-0	203		4	19'-0	203		4	19'-0	203	
SLAB LONGITUDINAL TOP			9b1	39	7'-9	454		39	7'-9	454		39	7'-9	454		39	7'-9	454	
SLAB LONGITUDINAL TOP			9b2	39	21'-3	2818		39	21'-3	2818		39	21'-3	2818		39	21'-3	2818	
SLAB LONGITUDINAL TOP			9b3	39	34'-3	4542		39	34'-3	4542		39	34'-3	4542		39	34'-3	4542	
SLAB LONGITUDINAL TOP			6b4	40	12'-9	767		40	12'-9	767		40	12'-9	767		40	12'-9	767	
SLAB LONGITUDINAL TOP			9b5	40	26'-0	3536		40	26'-0	3536		40	26'-0	3536		40	26'-0	3536	
SLAB LONGITUDINAL TOP			6b6	20	17'-6	526		20	17'-6	526		20	17'-6	526		20	17'-6	526	
SLAB LONGITUDINAL TOP, AT RAIL			6b8	8	26'-2	315		8	26'-2	315		8	26'-2	315		8	26'-2	315	
SLAB LONGITUDINAL TOP, AT RAIL			9b9	8	18'-0	490		8	18'-0	490		8	18'-0	490		8	18'-0	490	
SLAB LONGITUDINAL TOP, AT RAIL			6b10	4	18'-4	111		4	18'-4	111		4	18'-4	111		4	18'-4	111	
SLAB LONGITUDINAL TOP, AT RAIL			6b11	8	28'-8	345		8	28'-8	345		8	28'-8	345		8	28'-8	345	
SLAB LONGITUDINAL TOP, AT RAIL			10b12	8	11'-9	405		8	11'-9	405		8	11'-9	405		8	11'-9	405	
SLAB TRANSVERSE, BOTTOM			6c1	87	32'-10	4291		87	34'-0	4443		74	32'-10	3650		60	32'-10	2959	
SLAB TRANSVERSE ENDS, BOTTOM			6c2	-	-	-		-	-	-		30	VARIABLES	797		56	VARIABLES	1486	
SLAB TRANSVERSE, TOP			5d1	87	32'-10	2980		87	34'-0	3086		74	32'-10	2535		60	32'-10	2055	
SLAB TRANSVERSE ENDS, TOP			5d2	-	-	-		-	-	-		30	VARIABLES	553		56	VARIABLES	1032	
SLAB, TRANSVERSE AT ABUTMENT			8e1	18	32'-10	1578		-	-	-		-	-	-		-	-	-	
SLAB, TRANSVERSE AT ABUTMENT			8e2	-	-	-		18	33'-11	1631		18	37'-6	1803		18	45'-4	2179	
SLAB, HAIRPINS, AT ABUTMENT			6e3	72	5'-0	541		72	5'-1	550		72	5'-5	586		72	6'-1	658	
SLAB, DIAGONALS, AT ABUTMENT			6e4	72	5'-11	640		72	5'-11	640		72	5'-11	640		72	5'-11	640	
PIER CAP HOOPS			5h1	56	7'-3	424		56	7'-3	424		56	7'-3	424		70	7'-3	530	
PIER CAP ENDS			8h2	4	14'-5	154		4	14'-5	154		4	14'-5	154		4	14'-5	154	
PIER CAP, BOTTOM LONGITUDINAL			8h3	8	29'-10	638		8	30'-11	661		8	34'-5	736		8	42'-2	901	
PIER CAP, TOP LONGITUDINAL			8h4	4	32'-10	351		4	34'-0	364		4	37'-11	405		4	46'-6	497	
TOP OF SLAB, TRANSVERSE, AT RAIL			5j1	172	8'-6	1525		172	8'-6	1525		172	8'-6	1525		170	8'-6	1508	
WING, VERTICAL			5m1	40	4'-5	185		40	4'-5	185		40	4'-5	185		40	4'-5	185	
WING, HORIZONTAL BACK FACE			5n1	24	6'-8	167		24	6'-8	167		24	6'-8	167		24	6'-8	167	
WING, HORIZONTAL TRAFFIC FACE			5n3	24	6'-9	169		24	6'-9	169		24	6'-9	169		24	6'-9	169	
PAVING BLOCK LIFTING HOOPS			5z1	10	2'-10	30		10	2'-10	30		10	2'-10	30		10	2'-10	30	
SUB TOTAL - LBS.						41,418				41,774				42,104				42,895	
BARRIER RAIL - SEE LIST ON RAIL SHEET J30-41-06						5950				5950				5950				5950	
OPEN RAIL - SEE LIST ON RAIL SHEET J30-44-06						6330				6330				6330				6330	
TOTAL - LBS.																			
				WITH MONOLITHIC PIER CAP			WITH BARRIER RAIL	47,368		47,724			48,054			48,845			
							WITH OPEN RAIL	47,748		48,104			48,434			49,225			
TOTAL - LBS.				WITH NON-MONOLITHIC PIER CAP			WITH BARRIER RAIL	45,801		46,121			46,335			46,763			
SAME AS ABOVE EXCEPT ALL "h" BARS DELETED						46,181	WITH OPEN RAIL	46,501		46,501			46,715			47,143			

ESTIMATED QUANTITIES FOR SUPERSTRUCTURE - 90' BRIDGE

ITEM	SKEW	WITH MONOLITHIC PIER CAP				WITH NON-MONOLITHIC PIER CAP			
		0°	15°	30°	45°	0°	15°	30°	45°
WITH *STRUCTURAL CONCRETE (BRIDGE)	C.Y.	176.5	177.3	180.1	186.1	171.9	172.5	174.9	179.7
BARRIER RAIL REINFORCING STEEL	LBS.	47,368	47,724	48,054	48,845	45,801	46,121	46,335	46,763
CONCRETE BARRIER OR OPEN RAIL	LIN. FT.	202.0	202.2	202.9	204.5	202.0	202.2	202.9	204.5
WITH *STRUCTURAL CONCRETE (BRIDGE)	C.Y.	176.3	177.1	180.0	185.9	171.7	172.4	174.7	179.5
OPEN RAIL REINFORCING STEEL	LBS.	47,748	48,104	48,434	49,225	46,181	46,501	46,715	47,143

* INCLUDES 4 WINGS @ 0.68 C.Y. EACH AND 2 TEMPORARY PAVING BLOCKS; EXCLUDES RAIL CONCRETE.

BENT BAR DETAILS

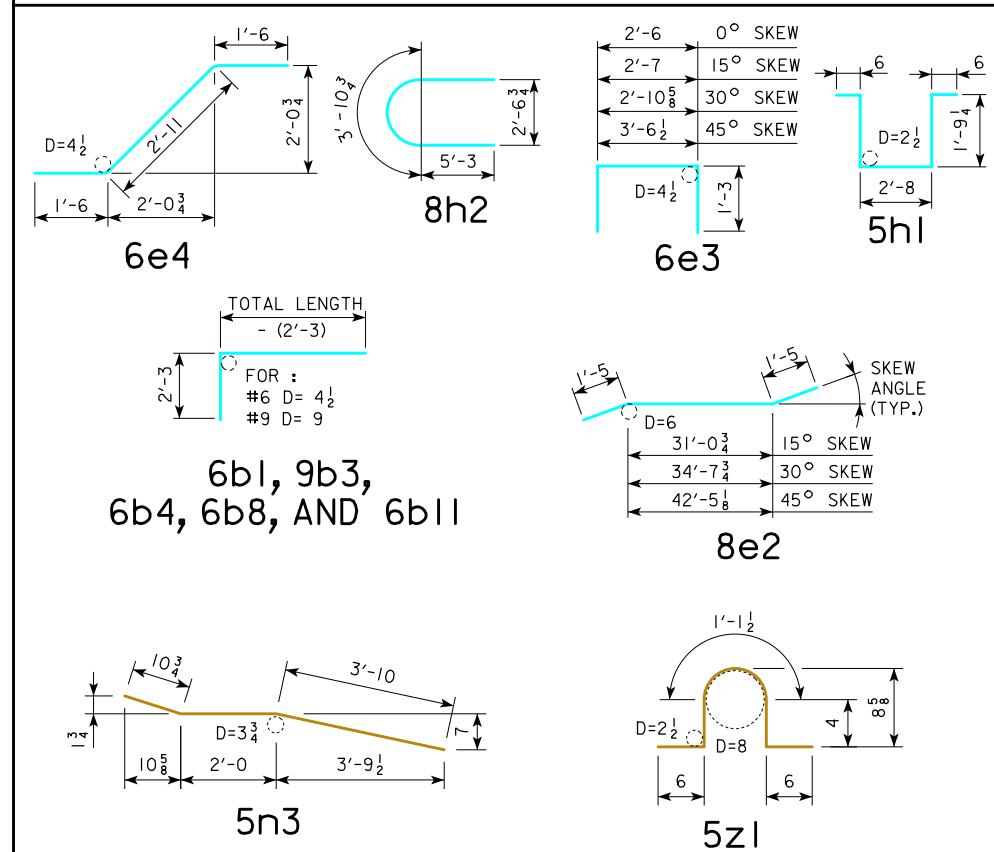

NOTE: ALL DIMENSIONS ARE OUT TO OUT. D = PIN DIAMETER.

09-2020 LATEST REVISION DATE	APPROVED BY BRIDGE ENGINEER		
		STANDARD DESIGN - 30' ROADWAY, 3 SPAN BRIDGES CONTINUOUS CONCRETE SLAB BRIDGES NOVEMBER, 2006	
		SUPERSTRUCTURE DETAILS 90'-0 BRIDGE	J30-07B-06

NON-EPOXY COATED REINFORCING

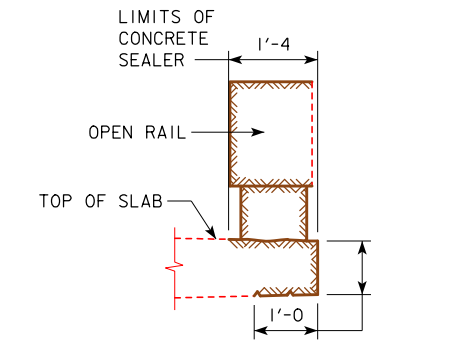
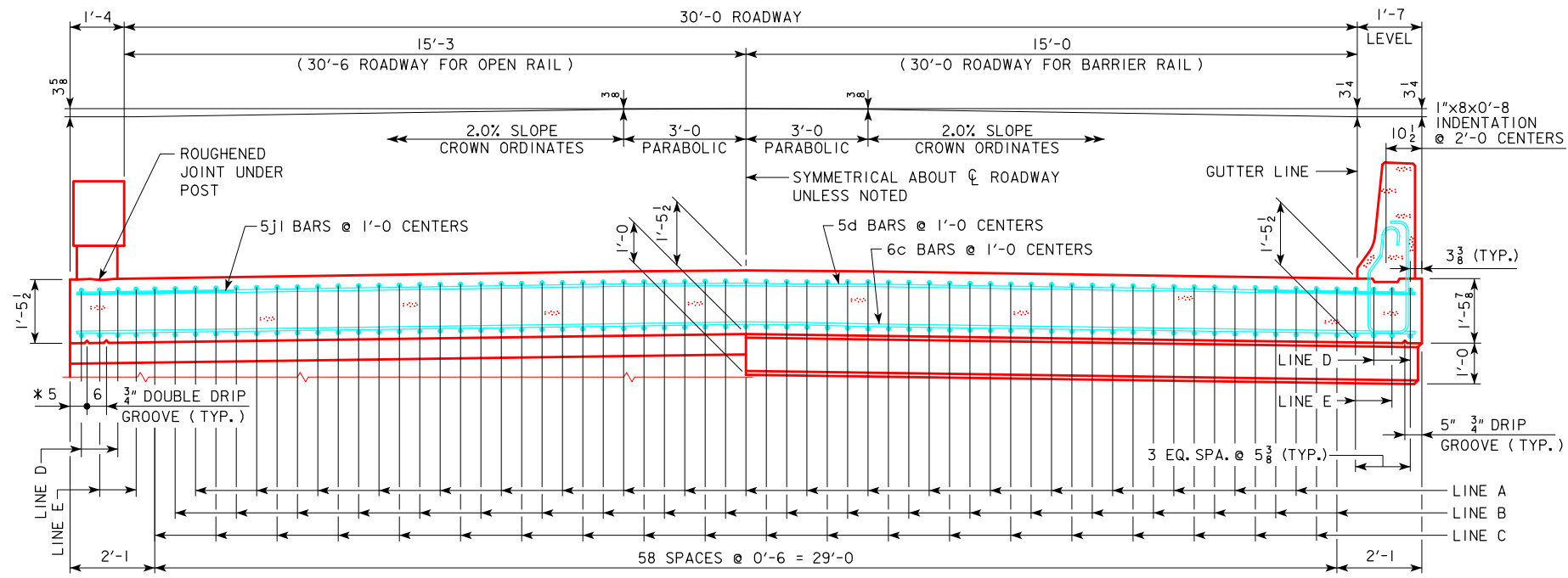

CONCRETE SEALER LIMITS FOR OPEN RAILS

CONCRETE SEALER SHALL BE APPLIED TO BOTH SIDES OF BRIDGE SLAB ON THE TOP, EDGE OF SLAB AND UNDER THE SLAB. THE CONCRETE SEALER SHALL ALSO BE APPLIED TO THE OPEN RAIL ON THE TOP, TRAFFIC FACE SIDE, BOTTOM OF RAIL, AND ON ALL SIDES OF THE OPEN RAIL POSTS.

THE CONCRETE SEALER LIMITS ARE SHOWN IN THE DETAIL AND SHALL APPLY TO THE FULL LENGTH OF BRIDGE. CONCRETE SEALER SHALL BE APPLIED IN ACCORDANCE WITH ARTICLE 2403.03, P, 3 OF THE STANDARD SPECIFICATIONS.

HALF SECTION NEAR ABUTMENT

HALF SECTION NEAR PIER

* NOTE: DOUBLE DRIP GROOVES FOR OPEN RAIL OPTION ONLY.

SLAB CROSS-SECTIONAL AREA FOR OPEN RAIL = 48.37 SQ. FT.

NOTE: TOP LONGITUDINAL REINFORCING STEEL IS TO BE PARALLEL TO AND 2 1/2" CLEAR BELOW TOP OF SLAB. BOTTOM LONGITUDINAL REINFORCING STEEL IS TO BE PARALLEL TO AND 1 1/2" CLEAR ABOVE BOTTOM OF SLAB. REINFORCING STEEL IS TO BE SECURELY WIRED IN PLACE AND ADEQUATELY SUPPORTED ON BAR CHAIRS BEFORE CONCRETE IS POURED. I.M. 451.01 REQUIREMENTS SHALL APPLY FOR BAR CHAIRS.

SLAB CROSS-SECTIONAL AREA FOR BARRIER RAIL = 48.42 SQ. FT.

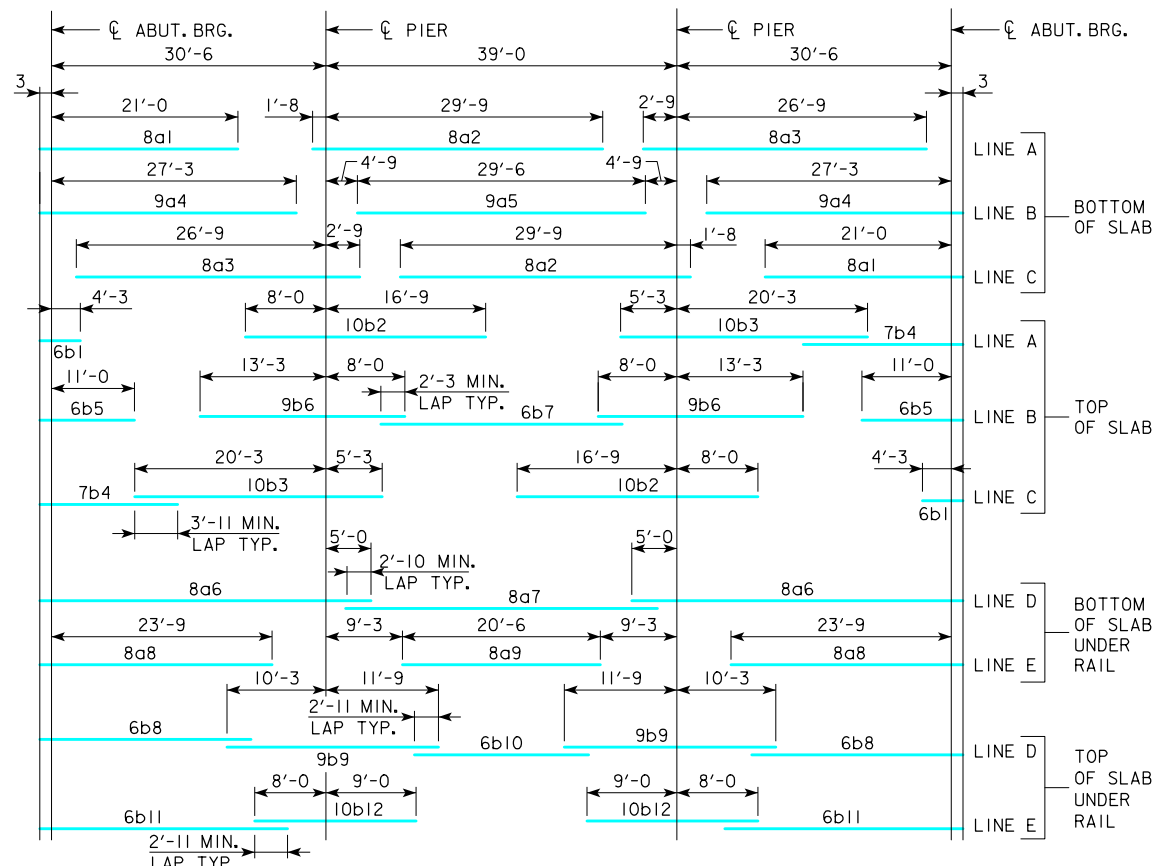

PLACEMENT FOR LONGITUDINAL REINFORCEMENT

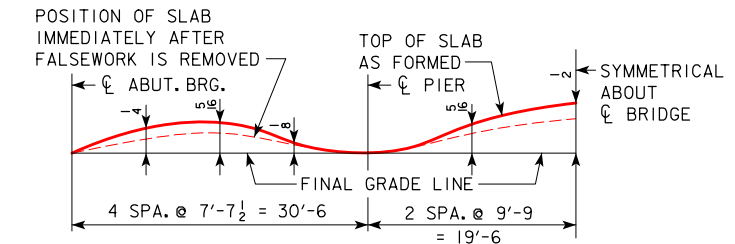

FORM CAMBER DIAGRAM

THIS DIAGRAM SHOWS THE FORM CAMBER REQUIRED TO COMPENSATE FOR THE ANTICIPATED ULTIMATE DEAD LOAD DEFLECTION. THE ABOVE DIMENSIONS DO NOT INCLUDE ANY ALLOWANCE FOR FORM DEFLECTION OR FALSEWORK SETTLEMENT.

REVISED 07-2016; DATE ON SHEET CHANGED TO CORRECT CLERICAL ERROR.
 REVISED 09-2020; UPDATED BRIDGE ENGINEER SIGNATURE.

09-2020 LATEST REVISION DATE	APPROVED BY BRIDGE ENGINEER		
		STANDARD DESIGN - 30' ROADWAY, 3 SPAN BRIDGES CONTINUOUS CONCRETE SLAB BRIDGES NOVEMBER, 2006	
		SUPERSTRUCTURE DETAILS 100'-0 BRIDGE	J30-08B-06
NON-EPOXY COATED REINFORCING			

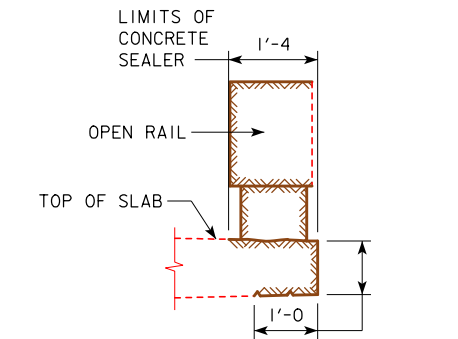
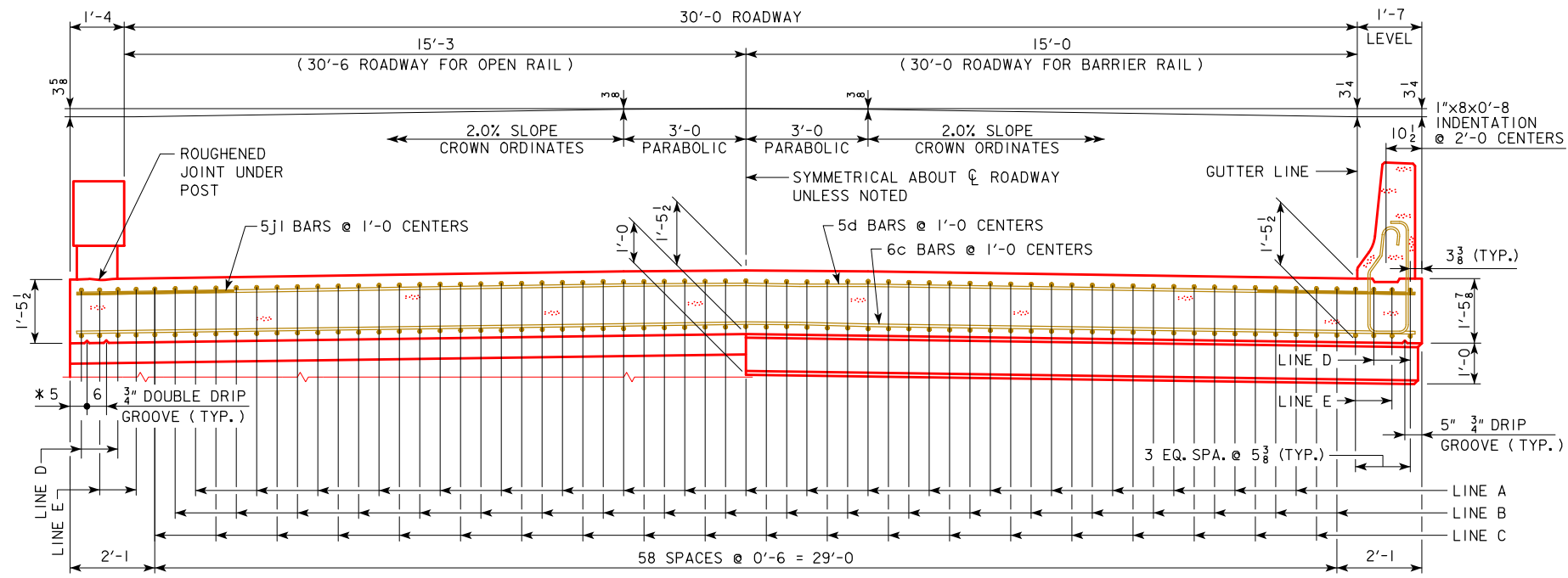

CONCRETE SEALER LIMITS FOR OPEN RAILS

CONCRETE SEALER SHALL BE APPLIED TO BOTH SIDES OF BRIDGE SLAB ON THE TOP, EDGE OF SLAB AND UNDER THE SLAB. THE CONCRETE SEALER SHALL ALSO BE APPLIED TO THE OPEN RAIL ON THE TOP, TRAFFIC FACE SIDE, BOTTOM OF RAIL, AND ON ALL SIDES OF THE OPEN RAIL POSTS.

THE CONCRETE SEALER LIMITS ARE SHOWN IN THE DETAIL AND SHALL APPLY TO THE FULL LENGTH OF BRIDGE. CONCRETE SEALER SHALL BE APPLIED IN ACCORDANCE WITH ARTICLE 2403.03, P, 3 OF THE STANDARD SPECIFICATIONS.

HALF SECTION NEAR ABUTMENT

HALF SECTION NEAR PIER

* NOTE: DOUBLE DRIP GROOVES FOR OPEN RAIL OPTION ONLY.

SLAB CROSS-SECTIONAL AREA FOR OPEN RAIL = 48.37 SQ. FT.

NOTE: TOP LONGITUDINAL REINFORCING STEEL IS TO BE PARALLEL TO AND 2 1/2" CLEAR BELOW TOP OF SLAB. BOTTOM LONGITUDINAL REINFORCING STEEL IS TO BE PARALLEL TO AND 1 1/2" CLEAR ABOVE BOTTOM OF SLAB. REINFORCING STEEL IS TO BE SECURELY WIRED IN PLACE AND ADEQUATELY SUPPORTED ON BAR CHAIRS BEFORE CONCRETE IS POURED. I.M. 451.01 REQUIREMENTS SHALL APPLY FOR BAR CHAIRS.

SLAB CROSS-SECTIONAL AREA FOR BARRIER RAIL = 48.42 SQ. FT.

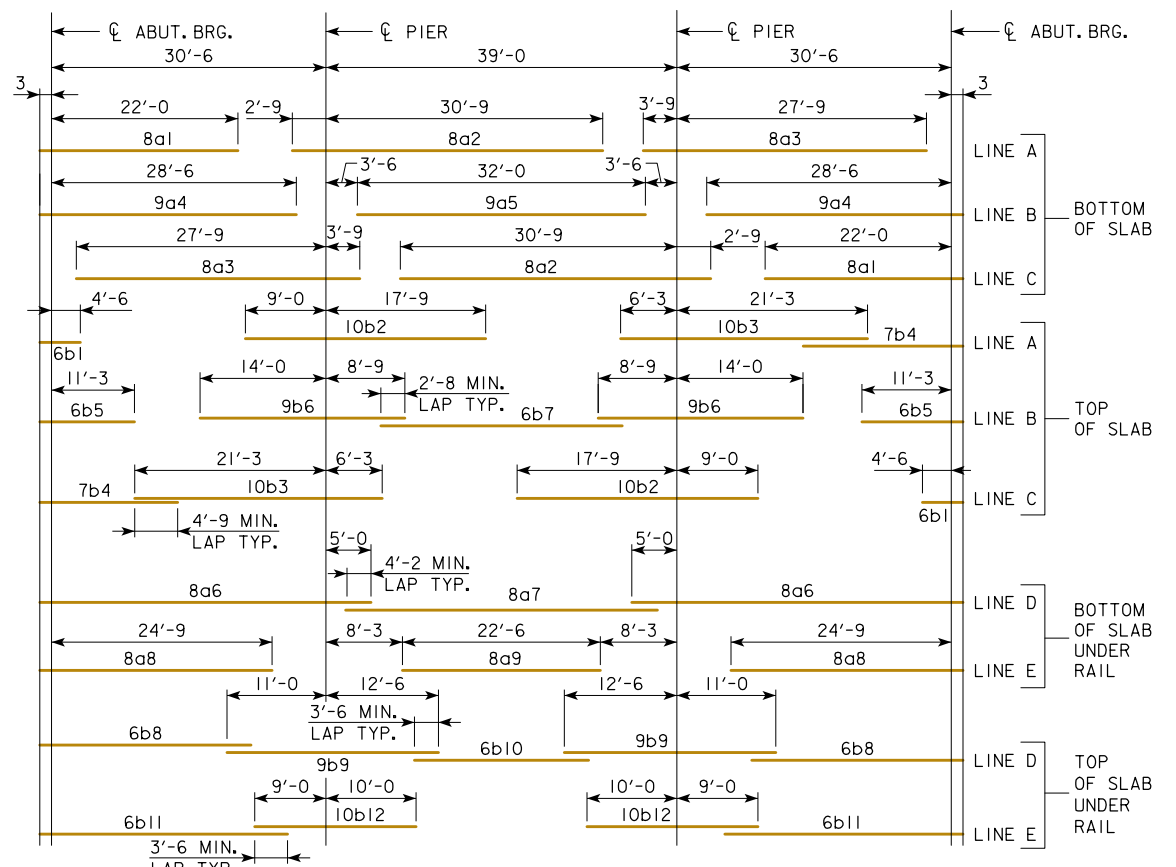

PLACEMENT FOR LONGITUDINAL REINFORCEMENT

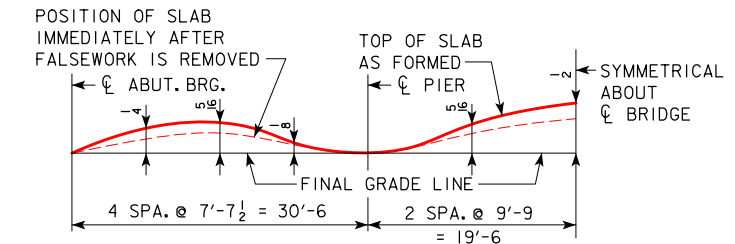

FORM CAMBER DIAGRAM

THIS DIAGRAM SHOWS THE FORM CAMBER REQUIRED TO COMPENSATE FOR THE ANTICIPATED ULTIMATE DEAD LOAD DEFLECTION. THE ABOVE DIMENSIONS DO NOT INCLUDE ANY ALLOWANCE FOR FORM DEFLECTION OR FALSEWORK SETTLEMENT.

REVISED 07-2016; DATE ON SHEET CHANGED TO CORRECT CLERICAL ERROR.
 REVISED 09-2020; UPDATED BRIDGE ENGINEER SIGNATURE.

09-2020 LATEST REVISION DATE		IOWADOT Highway Division	
		STANDARD DESIGN - 30' ROADWAY, 3 SPAN BRIDGES	
		CONTINUOUS CONCRETE SLAB BRIDGES NOVEMBER, 2006	
SUPERSTRUCTURE DETAILS 100'-0 BRIDGE		J30-08E-06	
EPOXY COATED REINFORCING			

BILL OF REINFORCING STEEL FOR SUPERSTRUCTURE - 100' BRIDGE

LOCATION	SKEW	SHAPE	BAR	0°				15°				30°				45°			
				NO.	LENGTH	WEIGHT		NO.	LENGTH	WEIGHT		NO.	LENGTH	WEIGHT		NO.	LENGTH	WEIGHT	
SLAB LONGITUDINAL BOTTOM			8a1	39	21'-3	2213		39	21'-3	2213		39	21'-3	2213		39	21'-3	2213	
SLAB LONGITUDINAL BOTTOM			8a2	39	31'-5	3272		39	31'-5	3272		39	31'-5	3272		39	31'-5	3272	
SLAB LONGITUDINAL BOTTOM			8a3	39	29'-6	3072		39	29'-6	3072		39	29'-6	3072		39	29'-6	3072	
SLAB LONGITUDINAL BOTTOM			9a4	40	27'-6	3740		40	27'-6	3740		40	27'-6	3740		40	27'-6	3740	
SLAB LONGITUDINAL BOTTOM			9a5	20	29'-6	2006		20	29'-6	2006		20	29'-6	2006		20	29'-6	2006	
SLAB LONGITUDINAL BOTTOM, AT RAIL			8a6	8	35'-9	764		8	35'-9	764		8	35'-9	764		8	35'-9	764	
SLAB LONGITUDINAL BOTTOM, AT RAIL			8a7	4	34'-8	371		4	34'-8	371		4	34'-8	371		4	34'-8	371	
SLAB LONGITUDINAL BOTTOM, AT RAIL			8a8	8	24'-0	513		8	24'-0	513		8	24'-0	513		8	24'-0	513	
SLAB LONGITUDINAL BOTTOM, AT RAIL			8a9	4	20'-6	219		4	20'-6	219		4	20'-6	219		4	20'-6	219	
SLAB LONGITUDINAL TOP			6b1	39	6'-9	396		39	6'-9	396		39	6'-9	396		39	6'-9	396	
SLAB LONGITUDINAL TOP			10b2	39	24'-9	4154		39	24'-9	4154		39	24'-9	4154		39	24'-9	4154	
SLAB LONGITUDINAL TOP			10b3	39	25'-6	4280		39	25'-6	4280		39	25'-6	4280		39	25'-6	4280	
SLAB LONGITUDINAL TOP			7b4	39	16'-8	1329		39	16'-8	1329		39	16'-8	1329		39	16'-8	1329	
SLAB LONGITUDINAL TOP			6b5	40	13'-6	812		40	13'-6	812		40	13'-6	812		40	13'-6	812	
SLAB LONGITUDINAL TOP			9b6	40	21'-3	2890		40	21'-3	2890		40	21'-3	2890		40	21'-3	2890	
SLAB LONGITUDINAL TOP			6b7	20	27'-6	827		20	27'-6	827		20	27'-6	827		20	27'-6	827	
SLAB LONGITUDINAL TOP, AT RAIL			6b8	8	25'-8	309		8	25'-8	309		8	25'-8	309		8	25'-8	309	
SLAB LONGITUDINAL TOP, AT RAIL			9b9	8	22'-0	599		8	22'-0	599		8	22'-0	599		8	22'-0	599	
SLAB LONGITUDINAL TOP, AT RAIL			6b10	4	21'-4	129		4	21'-4	129		4	21'-4	129		4	21'-4	129	
SLAB LONGITUDINAL TOP, AT RAIL			6b11	8	27'-11	336		8	27'-11	336		8	27'-11	336		8	27'-11	336	
SLAB LONGITUDINAL TOP, AT RAIL			10b12	8	17'-0	586		8	17'-0	586		8	17'-0	586		8	17'-0	586	
SLAB TRANSVERSE, BOTTOM			6c1	97	32'-10	4784		97	34'-0	4954		84	32'-10	4143		70	32'-10	3453	
SLAB TRANSVERSE ENDS, BOTTOM			6c2	-	-	-		-	-	-		30	VARIES	797		56	VARIES	1486	
SLAB TRANSVERSE, TOP			5d1	97	32'-10	3322		97	34'-0	3440		84	32'-10	2877		70	32'-10	2398	
SLAB TRANSVERSE ENDS, TOP			5d2	-	-	-		-	-	-		30	VARIES	553		56	VARIES	1032	
SLAB, TRANSVERSE AT ABUTMENT			8e1	18	32'-10	1578		-	-	-		-	-	-		-	-	-	
SLAB, TRANSVERSE AT ABUTMENT			8e2	-	-	-		18	33'-11	1631		18	37'-6	1803		18	45'-4	2179	
SLAB, HAIRPINS, AT ABUTMENT			6e3	72	5'-0	541		72	5'-1	550		72	5'-5	586		72	6'-1	658	
SLAB, DIAGONALS, AT ABUTMENT			6e4	72	5'-11	640		72	5'-11	640		72	5'-11	640		72	5'-11	640	
PIER CAP HOOPS			5h1	48	7'-5	372		48	7'-5	372		64	7'-5	496		64	7'-5	496	
PIER CAP ENDS			8h2	4	14'-5	154		4	14'-5	154		4	14'-5	154		4	14'-5	154	
PIER CAP, BOTTOM LONGITUDINAL			8h3	8	29'-10	638		8	30'-11	661		8	34'-5	736		8	42'-2	901	
PIER CAP, TOP LONGITUDINAL			8h4	4	32'-10	351		4	34'-0	364		4	37'-11	405		4	46'-6	497	
TOP OF SLAB, TRANSVERSE, AT RAIL			5j1	192	8'-6	1703		192	8'-6	1703		192	8'-6	1703		190	8'-6	1685	
WING, VERTICAL			5m1	40	4'-5	185		40	4'-5	185		40	4'-5	185		40	4'-5	185	
WING, HORIZONTAL BACK FACE			5n1	24	6'-8	167		24	6'-8	167		24	6'-8	167		24	6'-8	167	
WING, HORIZONTAL TRAFFIC FACE			5n3	24	6'-9	169		24	6'-9	169		24	6'-9	169		24	6'-9	169	
PAVING BLOCK LIFTING HOOPS			5z1	10	2'-10	30		10	2'-10	30		10	2'-10	30		10	2'-10	30	
SUB TOTAL - LBS.						47,451			47,837			48,261			48,947				
BARRIER RAIL - SEE LIST ON RAIL SHEET J30-41-06						6461			6461			6461			6461				
OPEN RAIL - SEE LIST ON RAIL SHEET J30-44-06						6794			6794			6794			6794				
TOTAL - LBS.				WITH MONOLITHIC PIER CAP	WITH BARRIER RAIL	53,912			54,298			54,722			55,408				
				WITH OPEN RAIL		54,245			54,631			55,055			55,741				
TOTAL - LBS.				WITH NON-MONOLITHIC PIER CAP	WITH BARRIER RAIL	52,397			52,747			52,931			53,360				
SAME AS ABOVE EXCEPT ALL "h" BARS DELETED				WITH OPEN RAIL		52,730			53,080			53,264			53,693				

ESTIMATED QUANTITIES FOR SUPERSTRUCTURE - 100' BRIDGE

ITEM	SKEW	WITH MONOLITHIC PIER CAP				WITH NON-MONOLITHIC PIER CAP				
		0°	15°	30°	45°	0°	15°	30°	45°	
WITH BARRIER RAIL	*STRUCTURAL CONCRETE (BRIDGE)	C.Y.	205.6	206.4	209.1	215.0	201.1	201.6	203.9	208.6
CONCRETE BARRIER OR OPEN RAIL	REINFORCING STEEL	LBS.	53,912	54,298	54,722	55,408	52,397	52,747	52,931	53,360
WITH OPEN RAIL	CONCRETE BARRIER OR OPEN RAIL	LIN. FT.	222.0	222.2	222.9	224.5	222.0	222.2	222.9	224.5
WITH OPEN RAIL	*STRUCTURAL CONCRETE (BRIDGE)	C.Y.	205.4	206.2	208.9	214.8	200.8	201.4	203.7	208.4
OPEN RAIL	REINFORCING STEEL	LBS.	54,245	54,631	55,055	55,741	52,730	53,080	53,264	53,693

* INCLUDES 4 WINGS @ 0.68 C.Y. EACH AND 2 TEMPORARY PAVING BLOCKS; EXCLUDES RAIL CONCRETE.

BENT BAR DETAILS

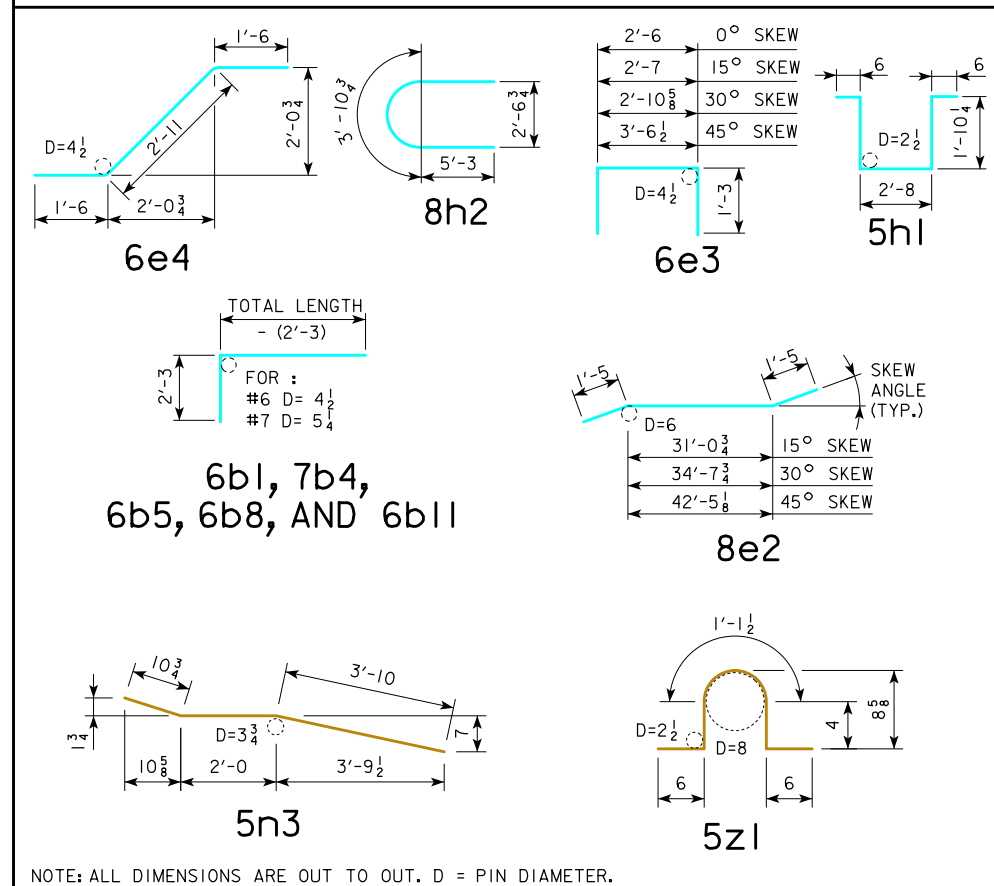

REVISED 07-2009; OPEN RAIL REINF. QTY'S. CHANGED WHICH CHANGED TOTAL REINF. QTY'S. REVISED 09-2020; UPDATED BRIDGE ENGINEER SIGNATURE. CHANGED PAVING BLOCK LIFTING HOOP BAR MARK, (WAS 5x1).

09-2020 LATEST REVISION DATE	 APPROVED BY BRIDGE ENGINEER	 STANDARD DESIGN - 30' ROADWAY, 3 SPAN BRIDGES CONTINUOUS CONCRETE SLAB BRIDGES NOVEMBER, 2006	
		SUPERSTRUCTURE DETAILS 100'-0 BRIDGE NON-EPOXY COATED REINFORCING	J30-09B-06

REVISED 07-2009: OPEN RAIL REINF. QTY'S. CHANGED WHICH CHANGED TOTAL REINF. QTY'S.
REVISED 09-2020: UPDATED BRIDGE ENGINEER SIGNATURE. CHANGED PAVING BLOCK LIFTING HOOP BAR MARK, (WAS 5X1).

BILL OF REINFORCING STEEL FOR SUPERSTRUCTURE - 100' BRIDGE

LOCATION	SKEW	SHAPE	BAR	0°				15°				30°				45°			
				NO.	LENGTH	WEIGHT		NO.	LENGTH	WEIGHT		NO.	LENGTH	WEIGHT		NO.	LENGTH	WEIGHT	
SLAB LONGITUDINAL BOTTOM			8a1	39	22'-3	2317		39	22'-3	2317		39	22'-3	2317		39	22'-3	2317	
SLAB LONGITUDINAL BOTTOM			8a2	39	33'-6	3489		39	33'-6	3489		39	33'-6	3489		39	33'-6	3489	
SLAB LONGITUDINAL BOTTOM			8a3	39	31'-6	3281		39	31'-6	3281		39	31'-6	3281		39	31'-6	3281	
SLAB LONGITUDINAL BOTTOM			9a4	40	28'-9	3910		40	28'-9	3910		40	28'-9	3910		40	28'-9	3910	
SLAB LONGITUDINAL BOTTOM			9a5	20	32'-0	2176		20	32'-0	2176		20	32'-0	2176		20	32'-0	2176	
SLAB LONGITUDINAL BOTTOM, AT RAIL			8a6	8	35'-9	764		8	35'-9	764		8	35'-9	764		8	35'-9	764	
SLAB LONGITUDINAL BOTTOM, AT RAIL			8a7	4	37'-4	399		4	37'-4	399		4	37'-4	399		4	37'-4	399	
SLAB LONGITUDINAL BOTTOM, AT RAIL			8a8	8	25'-0	534		8	25'-0	534		8	25'-0	534		8	25'-0	534	
SLAB LONGITUDINAL BOTTOM, AT RAIL			8a9	4	22'-6	241		4	22'-6	241		4	22'-6	241		4	22'-6	241	
SLAB LONGITUDINAL TOP			6b1	39	7'-0	411		39	7'-0	411		39	7'-0	411		39	7'-0	411	
SLAB LONGITUDINAL TOP			10b2	39	26'-9	4490		39	26'-9	4490		39	26'-9	4490		39	26'-9	4490	
SLAB LONGITUDINAL TOP			10b3	39	27'-6	4615		39	27'-6	4615		39	27'-6	4615		39	27'-6	4615	
SLAB LONGITUDINAL TOP			7b4	39	16'-6	1316		39	16'-6	1316		39	16'-6	1316		39	16'-6	1316	
SLAB LONGITUDINAL TOP			6b5	40	13'-9	827		40	13'-9	827		40	13'-9	827		40	13'-9	827	
SLAB LONGITUDINAL TOP			9b6	40	22'-9	3094		40	22'-9	3094		40	22'-9	3094		40	22'-9	3094	
SLAB LONGITUDINAL TOP			6b7	20	26'-10	807		20	26'-10	807		20	26'-10	807		20	26'-10	807	
SLAB LONGITUDINAL TOP, AT RAIL			6b8	8	25'-6	307		8	25'-6	307		8	25'-6	307		8	25'-6	307	
SLAB LONGITUDINAL TOP, AT RAIL			9b9	8	23'-6	640		8	23'-6	640		8	23'-6	640		8	23'-6	640	
SLAB LONGITUDINAL TOP, AT RAIL			6b10	4	21'-0	127		4	21'-0	127		4	21'-0	127		4	21'-0	127	
SLAB LONGITUDINAL TOP, AT RAIL			6b11	8	27'-6	331		8	27'-6	331		8	27'-6	331		8	27'-6	331	
SLAB LONGITUDINAL TOP, AT RAIL			10b12	8	19'-0	655		8	19'-0	655		8	19'-0	655		8	19'-0	655	
SLAB TRANSVERSE, BOTTOM			6c1	97	32'-10	4784		97	34'-0	4954		84	32'-10	4143		70	32'-10	3453	
SLAB TRANSVERSE ENDS, BOTTOM			6c2	-	-	-		-	-	-		30	VARIES	797		56	VARIES	1486	
SLAB TRANSVERSE, TOP			5d1	97	32'-10	3322		97	34'-0	3440		84	32'-10	2877		70	32'-10	2398	
SLAB TRANSVERSE ENDS, TOP			5d2	-	-	-		-	-	-		30	VARIES	553		56	VARIES	1032	
SLAB, TRANSVERSE AT ABUTMENT			8e1	18	32'-10	1578		-	-	-		-	-	-		-	-	-	
SLAB, TRANSVERSE AT ABUTMENT			8e2	-	-	-		18	33'-11	1631		18	37'-6	1803		18	45'-4	2179	
SLAB, HAIRPINS, AT ABUTMENT			6e3	72	5'-0	541		72	5'-1	550		72	5'-5	586		72	6'-1	658	
SLAB, DIAGONALS, AT ABUTMENT			6e4	72	5'-11	640		72	5'-11	640		72	5'-11	640		72	5'-11	640	
PIER CAP HOOPS			5h1	48	7'-5	372		48	7'-5	372		64	7'-5	496		64	7'-5	496	
PIER CAP ENDS			8h2	4	14'-5	154		4	14'-5	154		4	14'-5	154		4	14'-5	154	
PIER CAP, BOTTOM LONGITUDINAL			8h3	8	29'-10	638		8	30'-11	661		8	34'-5	736		8	42'-2	901	
PIER CAP, TOP LONGITUDINAL			8h4	4	32'-10	351		4	34'-0	364		4	37'-11	405		4	46'-6	497	
TOP OF SLAB, TRANSVERSE, AT RAIL			5j1	192	8'-6	1703		192	8'-6	1703		192	8'-6	1703		190	8'-6	1685	
WING, VERTICAL			5m1	40	4'-5	185		40	4'-5	185		40	4'-5	185		40	4'-5	185	
WING, HORIZONTAL BACK FACE			5n1	24	6'-8	167		24	6'-8	167		24	6'-8	167		24	6'-8	167	
WING, HORIZONTAL TRAFFIC FACE			5n3	24	6'-9	169		24	6'-9	169		24	6'-9	169		24	6'-9	169	
** PAVING BLOCK LIFTING HOOPS			5z1	10	2'-10	30		10	2'-10	30		10	2'-10	30		10	2'-10	30	
SUB TOTAL - LBS.						49,365				49,751				50,175				50,861	
BARRIER RAIL - SEE LIST ON RAIL SHEET J30-41-06						6461				6461				6461				6461	
OPEN RAIL - SEE LIST ON RAIL SHEET J30-44-06						6794				6794				6794				6794	
TOTAL - LBS.																			
				WITH MONOLITHIC PIER CAP															
				WITH BARRIER RAIL		55,826				56,212				56,636				57,322	
				WITH OPEN RAIL		56,159				56,545				56,969				57,655	
TOTAL - LBS.				WITH NON-MONOLITHIC PIER CAP															
				WITH BARRIER RAIL		54,311				54,661				54,845				55,274	
				WITH OPEN RAIL		54,644				54,994				55,178				55,607	
SAME AS ABOVE EXCEPT ALL "h" BARS DELETED						54,644				54,994				55,178				55,607	

** BARS MAY BE NON-COATED AT CONTRACTOR'S OPTION.

ESTIMATED QUANTITIES FOR SUPERSTRUCTURE - 100' BRIDGE

ITEM	SKEW	WITH MONOLITHIC PIER CAP				WITH NON-MONOLITHIC PIER CAP			
		0°	15°	30°	45°	0°	15°	30°	45°
WITH *STRUCTURAL CONCRETE (BRIDGE) C.Y.		205.6	206.4	209.1	215.0	201.0	201.6	203.9	208.6
BARRIER RAIL REINFORCING STEEL EPOXY COATED LBS.		55,826	56,212	56,636	57,322	54,311	54,661	54,845	55,274
CONCRETE BARRIER OR OPEN RAIL LIN. FT.		222.0	222.2	222.9	224.5	222.0	222.2	222.9	224.5
WITH *STRUCTURAL CONCRETE (BRIDGE) C.Y.		205.4	206.2	208.9	214.8	200.8	201.4	203.7	208.4
OPEN RAIL REINFORCING STEEL EPOXY COATED LBS.		56,159	56,545	56,969	57,655	54,644	54,994	55,178	55,607

* INCLUDES 4 WINGS @ 0.68 C.Y. EACH AND 2 TEMPORARY PAVING BLOCKS; EXCLUDES RAIL CONCRETE.

BENT BAR DETAILS

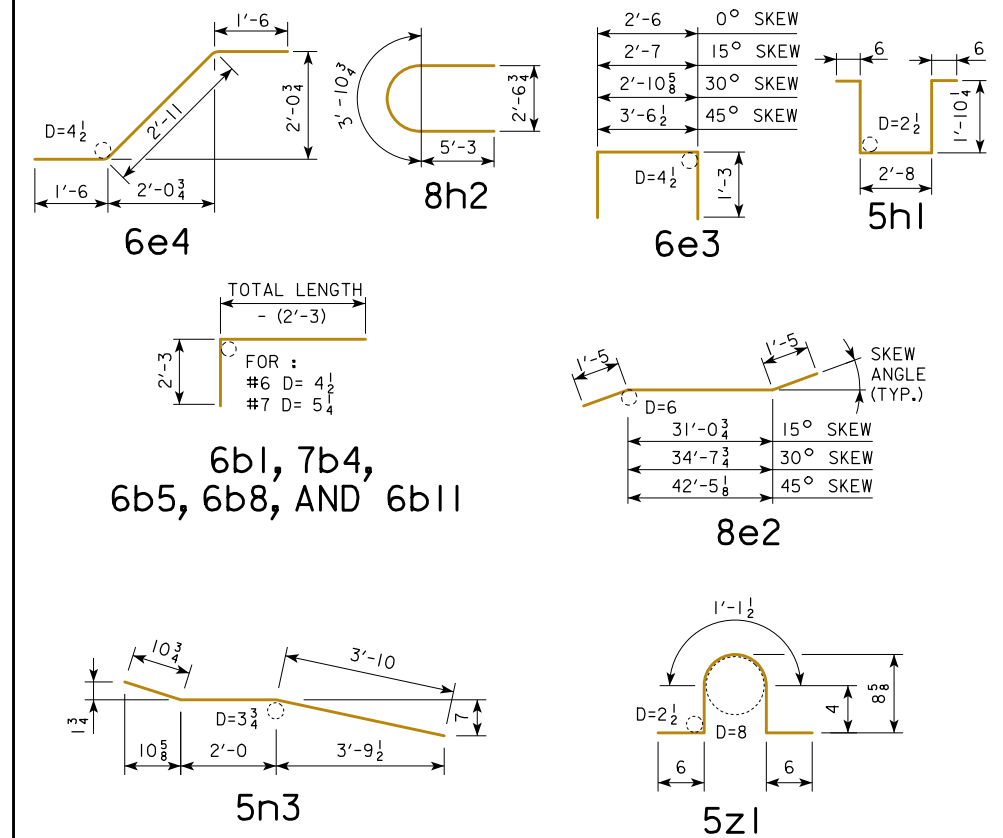

NOTE: ALL DIMENSIONS ARE OUT TO OUT. D = PIN DIAMETER.

09-2020 LATEST REVISION DATE	 APPROVED BY BRIDGE ENGINEER	
		STANDARD DESIGN - 30' ROADWAY, 3 SPAN BRIDGES CONTINUOUS CONCRETE SLAB BRIDGES NOVEMBER, 2006
		<div style="text-align: center;"> SUPERSTRUCTURE DETAILS 100'-0 BRIDGE EPOXY COATED REINFORCING </div> <div style="text-align: right; font-size: 1.2em;"> J30-09E-06 </div>

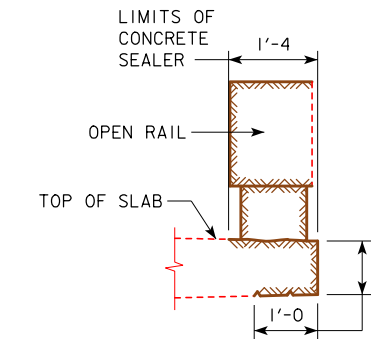
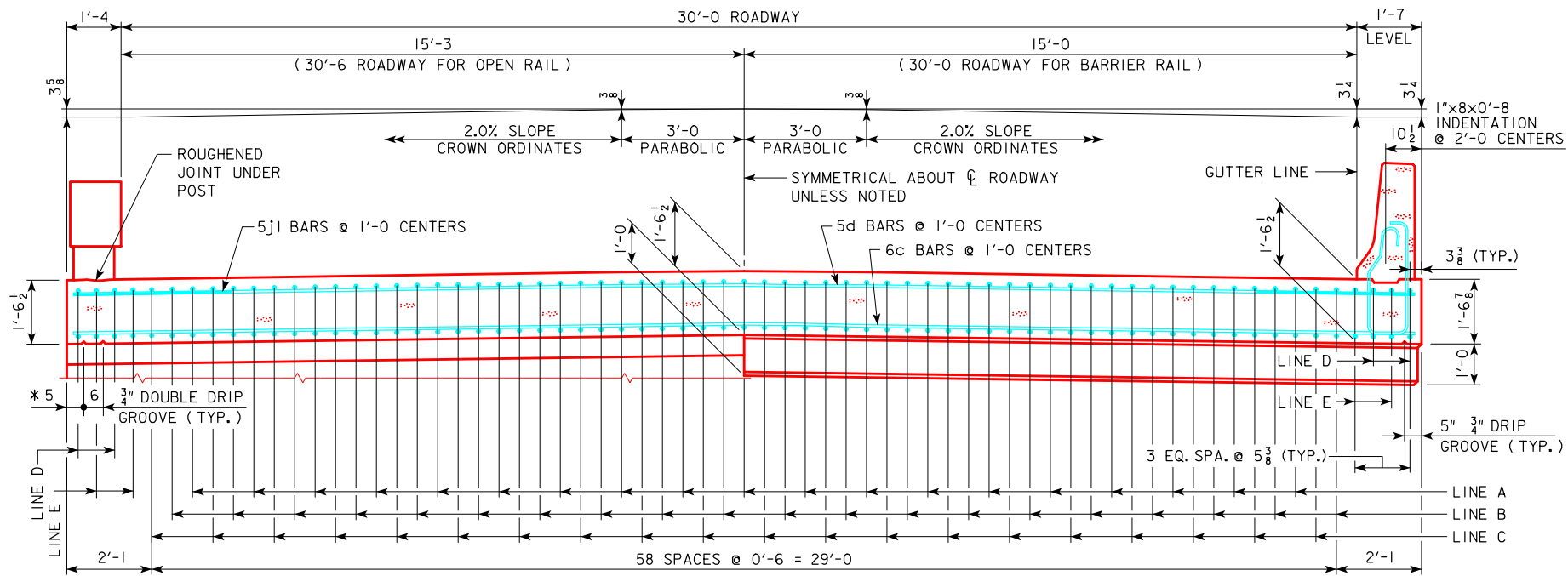

CONCRETE SEALER LIMITS FOR OPEN RAILS

CONCRETE SEALER SHALL BE APPLIED TO BOTH SIDES OF BRIDGE SLAB ON THE TOP, EDGE OF SLAB AND UNDER THE SLAB. THE CONCRETE SEALER SHALL ALSO BE APPLIED TO THE OPEN RAIL ON THE TOP, TRAFFIC FACE SIDE, BOTTOM OF RAIL, AND ON ALL SIDES OF THE OPEN RAIL POSTS.

THE CONCRETE SEALER LIMITS ARE SHOWN IN THE DETAIL AND SHALL APPLY TO THE FULL LENGTH OF BRIDGE. CONCRETE SEALER SHALL BE APPLIED IN ACCORDANCE WITH ARTICLE 2403.03, P, 3 OF THE STANDARD SPECIFICATIONS.

HALF SECTION NEAR ABUTMENT

HALF SECTION NEAR PIER

* NOTE: DOUBLE DRIP GROOVES FOR OPEN RAIL OPTION ONLY.

SLAB CROSS-SECTIONAL AREA FOR OPEN RAIL = 51.14 SQ. FT.

NOTE: TOP LONGITUDINAL REINFORCING STEEL IS TO BE PARALLEL TO AND 2 1/2" CLEAR BELOW TOP OF SLAB. BOTTOM LONGITUDINAL REINFORCING STEEL IS TO BE PARALLEL TO AND 1 1/2" CLEAR ABOVE BOTTOM OF SLAB. REINFORCING STEEL IS TO BE SECURELY WIRED IN PLACE AND ADEQUATELY SUPPORTED ON BAR CHAIRS BEFORE CONCRETE IS POURED. I.M. 451.01 REQUIREMENTS SHALL APPLY FOR BAR CHAIRS.

SLAB CROSS-SECTIONAL AREA FOR BARRIER RAIL = 51.19 SQ. FT.

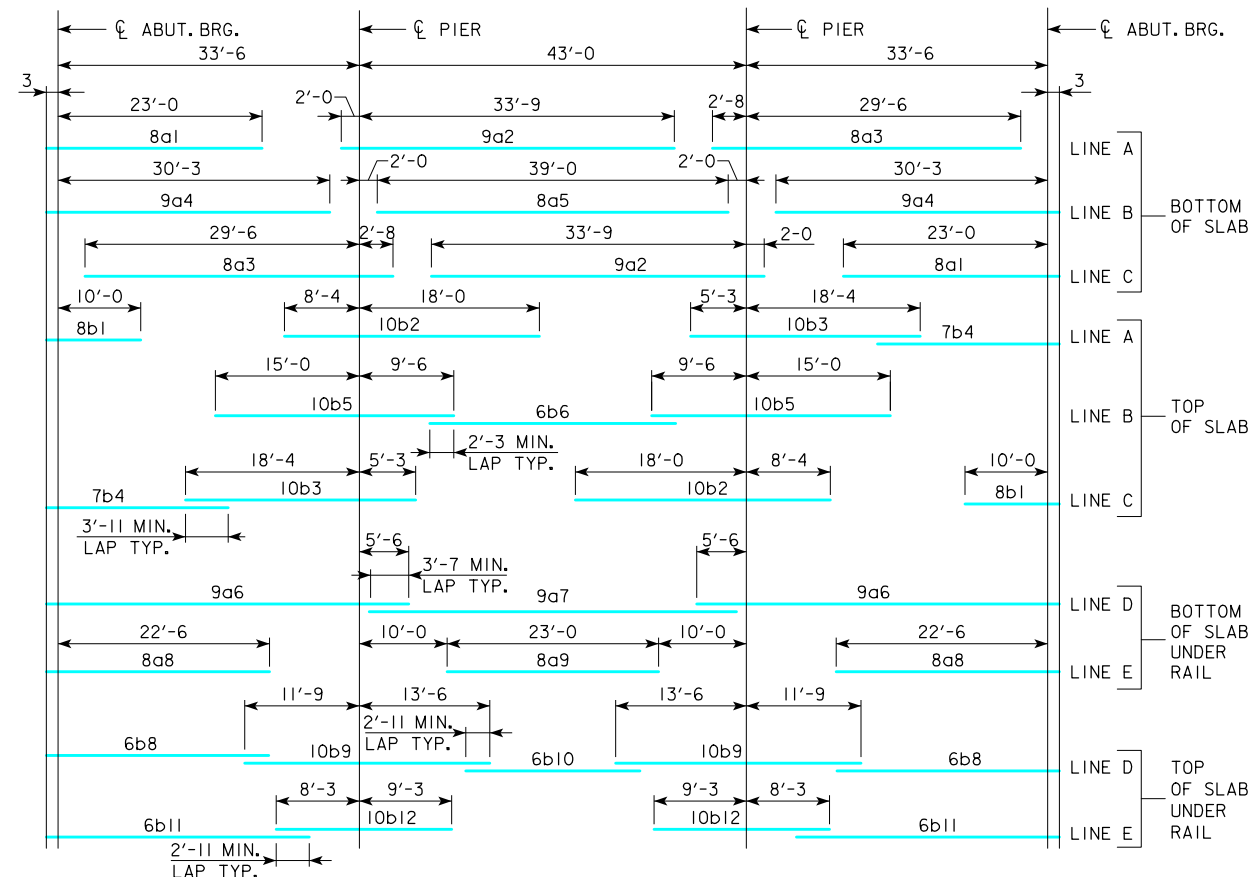

PLACEMENT FOR LONGITUDINAL REINFORCEMENT

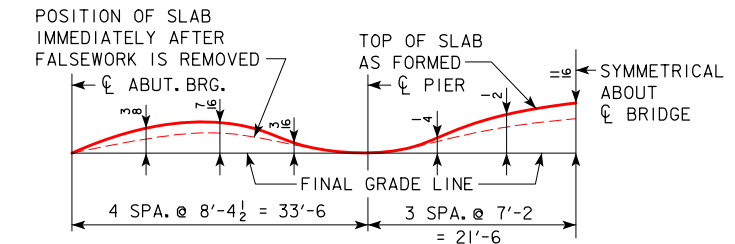

FORM CAMBER DIAGRAM

THIS DIAGRAM SHOWS THE FORM CAMBER REQUIRED TO COMPENSATE FOR THE ANTICIPATED ULTIMATE DEAD LOAD DEFLECTION. THE ABOVE DIMENSIONS DO NOT INCLUDE ANY ALLOWANCE FOR FORM DEFLECTION OR FALSEWORK SETTLEMENT.

REVISED 07-2016; DATE ON SHEET CHANGED TO CORRECT CLERICAL ERROR.
 REVISED 09-2020; UPDATED BRIDGE ENGINEER SIGNATURE.

09-2020 LATEST REVISION DATE APPROVED BY BRIDGE ENGINEER		
	STANDARD DESIGN - 30' ROADWAY, 3 SPAN BRIDGES CONTINUOUS CONCRETE SLAB BRIDGES NOVEMBER, 2006	
	SUPERSTRUCTURE DETAILS 110'-0 BRIDGE	J30-10B-06

NON-EPOXY COATED REINFORCING

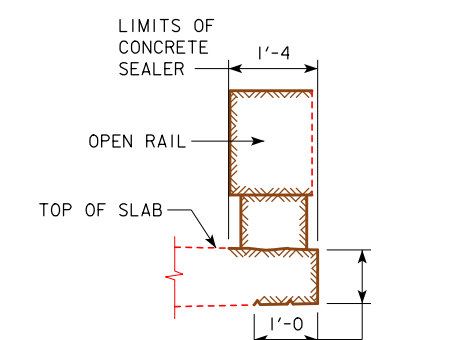
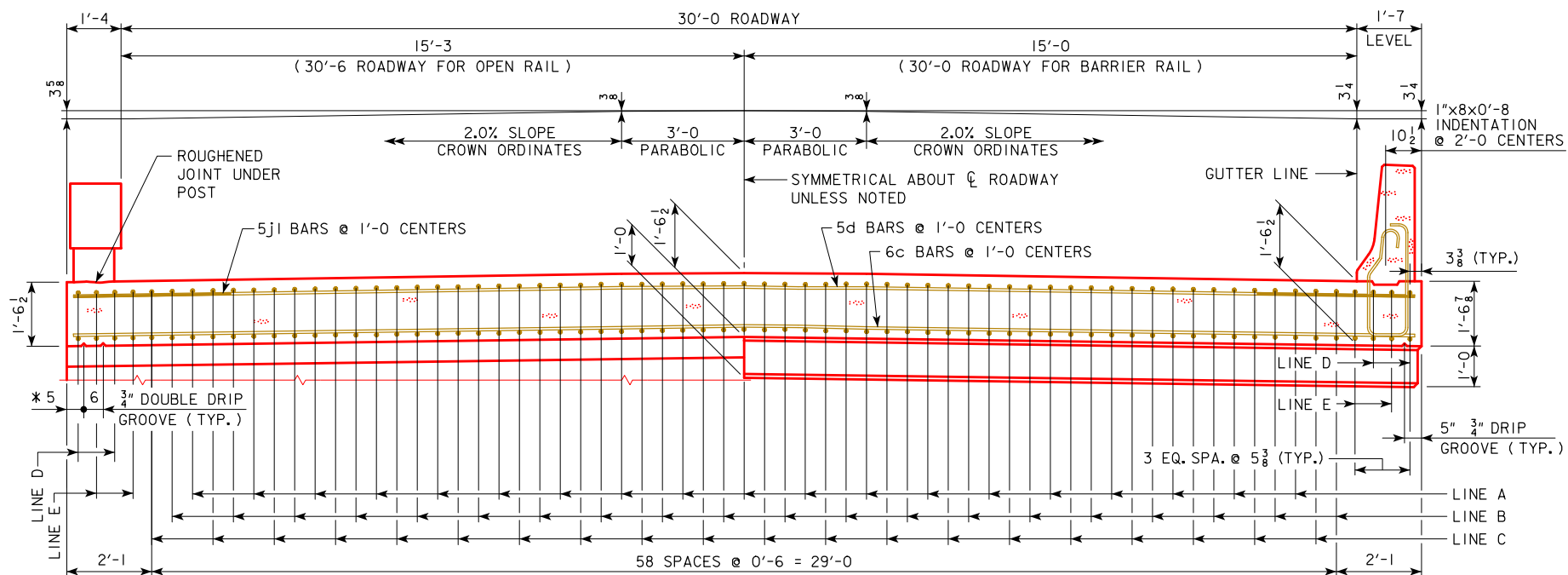

CONCRETE SEALER LIMITS FOR OPEN RAILS

CONCRETE SEALER SHALL BE APPLIED TO BOTH SIDES OF BRIDGE SLAB ON THE TOP, EDGE OF SLAB AND UNDER THE SLAB. THE CONCRETE SEALER SHALL ALSO BE APPLIED TO THE OPEN RAIL ON THE TOP, TRAFFIC FACE SIDE, BOTTOM OF RAIL, AND ON ALL SIDES OF THE OPEN RAIL POSTS.

THE CONCRETE SEALER LIMITS ARE SHOWN IN THE DETAIL AND SHALL APPLY TO THE FULL LENGTH OF BRIDGE. CONCRETE SEALER SHALL BE APPLIED IN ACCORDANCE WITH ARTICLE 2403.03, P, 3 OF THE STANDARD SPECIFICATIONS.

HALF SECTION NEAR ABUTMENT

* NOTE: DOUBLE DRIP GROOVES FOR OPEN RAIL OPTION ONLY.

SLAB CROSS-SECTIONAL AREA FOR OPEN RAIL = 51.14 SQ. FT.

NOTE: TOP LONGITUDINAL REINFORCING STEEL IS TO BE PARALLEL TO AND 2 1/2" CLEAR BELOW TOP OF SLAB. BOTTOM LONGITUDINAL REINFORCING STEEL IS TO BE PARALLEL TO AND 1 1/2" CLEAR ABOVE BOTTOM OF SLAB. REINFORCING STEEL IS TO BE SECURELY WIRED IN PLACE AND ADEQUATELY SUPPORTED ON BAR CHAIRS BEFORE CONCRETE IS POURED. I.M. 451.01 REQUIREMENTS SHALL APPLY FOR BAR CHAIRS.

HALF SECTION NEAR PIER

SLAB CROSS-SECTIONAL AREA FOR BARRIER RAIL = 51.19 SQ. FT.

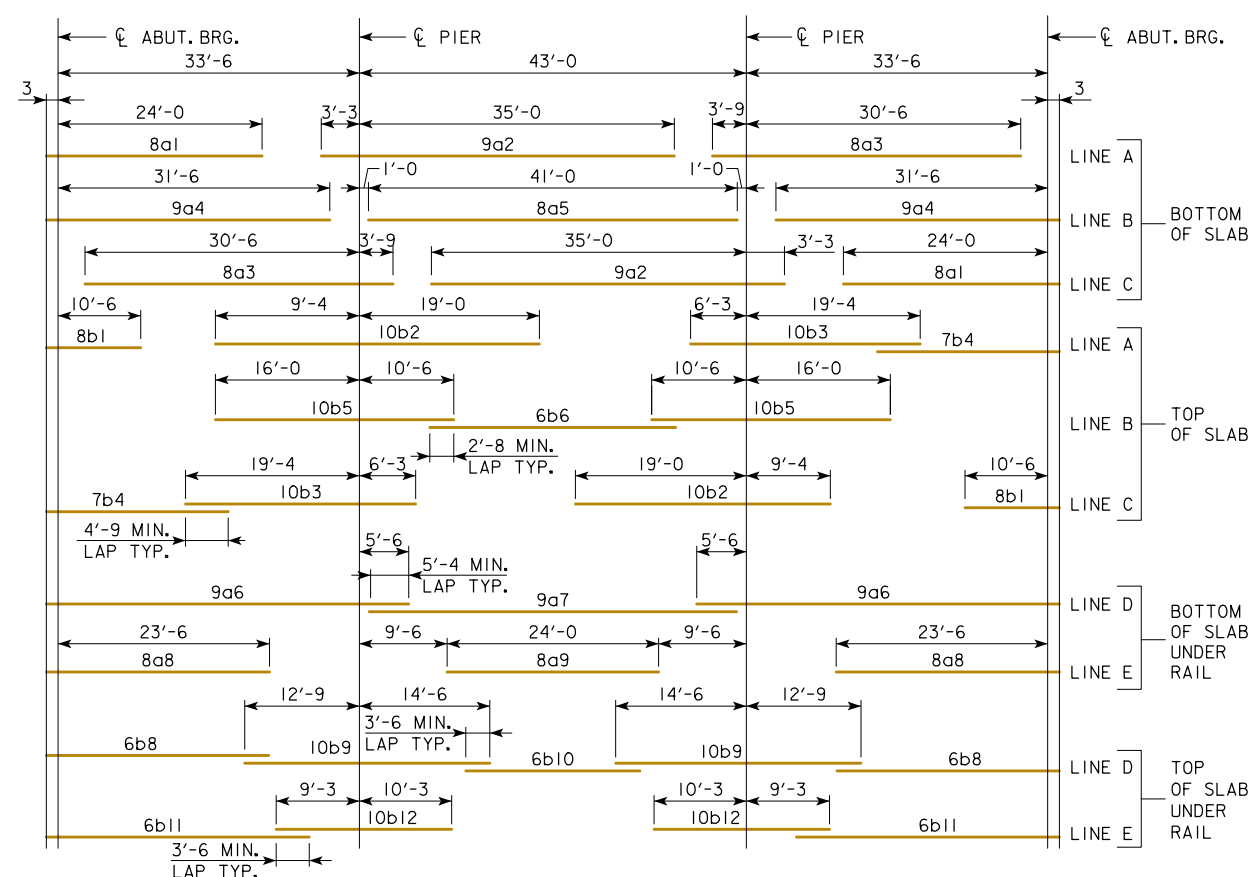

PLACEMENT FOR LONGITUDINAL REINFORCEMENT

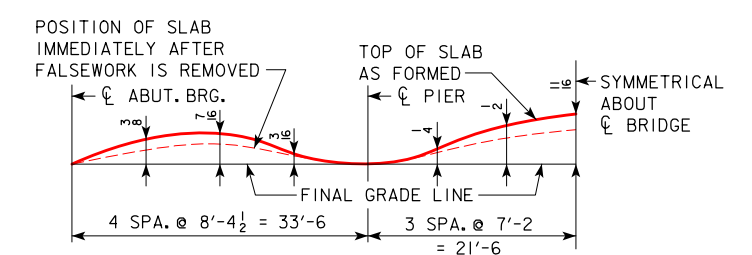

FORM CAMBER DIAGRAM

THIS DIAGRAM SHOWS THE FORM CAMBER REQUIRED TO COMPENSATE FOR THE ANTICIPATED ULTIMATE DEAD LOAD DEFLECTION. THE ABOVE DIMENSIONS DO NOT INCLUDE ANY ALLOWANCE FOR FORM DEFLECTION OR FALSEWORK SETTLEMENT.

REVISED 07-2016; DATE ON SHEET CHANGED TO CORRECT CLERICAL ERROR.
 REVISED 09-2020; UPDATED BRIDGE ENGINEER SIGNATURE.

09-2020 LATEST REVISION DATE	<i>[Signature]</i> APPROVED BY BRIDGE ENGINEER		
		STANDARD DESIGN - 30' ROADWAY, 3 SPAN BRIDGES CONTINUOUS CONCRETE SLAB BRIDGES NOVEMBER, 2006	
		SUPERSTRUCTURE DETAILS 110'-0 BRIDGE EPOXY COATED REINFORCING	J30-10E-06

BILL OF REINFORCING STEEL FOR SUPERSTRUCTURE - 110' BRIDGE

LOCATION	SKEW	SHAPE	BAR	0°				15°				30°				45°			
				NO.	LENGTH	WEIGHT		NO.	LENGTH	WEIGHT		NO.	LENGTH	WEIGHT		NO.	LENGTH	WEIGHT	
SLAB LONGITUDINAL BOTTOM			8a1	39	23'-3	2422		39	23'-3	2422		39	23'-3	2422		39	23'-3	2422	
SLAB LONGITUDINAL BOTTOM, AT RAIL			9a2	39	35'-9	4741		39	35'-9	4741		39	35'-9	4741		39	35'-9	4741	
SLAB LONGITUDINAL BOTTOM			8a3	39	32'-2	3350		39	32'-2	3350		39	32'-2	3350		39	32'-2	3350	
SLAB LONGITUDINAL BOTTOM, AT RAIL			9a4	40	30'-6	4148		40	30'-6	4148		40	30'-6	4148		40	30'-6	4148	
SLAB LONGITUDINAL BOTTOM			8a5	20	39'-0	2083		20	39'-0	2083		20	39'-0	2083		20	39'-0	2083	
SLAB LONGITUDINAL BOTTOM, AT RAIL			9a6	8	39'-3	1068		8	39'-3	1068		8	39'-3	1068		8	39'-3	1068	
SLAB LONGITUDINAL BOTTOM, AT RAIL			9a7	4	39'-2	533		4	39'-2	533		4	39'-2	533		4	39'-2	533	
SLAB LONGITUDINAL BOTTOM, AT RAIL			8a8	8	22'-9	486		8	22'-9	486		8	22'-9	486		8	22'-9	486	
SLAB LONGITUDINAL BOTTOM, AT RAIL			8a9	4	23'-0	246		4	23'-0	246		4	23'-0	246		4	23'-0	246	
SLAB LONGITUDINAL TOP			8b1	39	12'-6	1302		39	12'-6	1302		39	12'-6	1302		39	12'-6	1302	
SLAB LONGITUDINAL TOP			10b2	39	26'-4	4420		39	26'-4	4420		39	26'-4	4420		39	26'-4	4420	
SLAB LONGITUDINAL TOP			10b3	39	23'-7	3958		39	23'-7	3958		39	23'-7	3958		39	23'-7	3958	
SLAB LONGITUDINAL TOP			7b4	39	21'-7	1721		39	21'-7	1721		39	21'-7	1721		39	21'-7	1721	
SLAB LONGITUDINAL TOP			10b5	40	24'-6	4217		40	24'-6	4217		40	24'-6	4217		40	24'-6	4217	
SLAB LONGITUDINAL TOP			6b6	20	28'-6	857		20	28'-6	857		20	28'-6	857		20	28'-6	857	
SLAB LONGITUDINAL TOP, AT RAIL			6b8	8	27'-2	327		8	27'-2	327		8	27'-2	327		8	27'-2	327	
SLAB LONGITUDINAL TOP, AT RAIL			10b9	8	25'-3	870		8	25'-3	870		8	25'-3	870		8	25'-3	870	
SLAB LONGITUDINAL TOP, AT RAIL			6b10	4	21'-10	132		4	21'-10	132		4	21'-10	132		4	21'-10	132	
SLAB LONGITUDINAL TOP, AT RAIL			6b11	8	30'-8	369		8	30'-8	369		8	30'-8	369		8	30'-8	369	
SLAB LONGITUDINAL TOP, AT RAIL			10b12	8	17'-6	603		8	17'-6	603		8	17'-6	603		8	17'-6	603	
SLAB TRANSVERSE, BOTTOM			6c1	107	32'-10	5277		107	34'-0	5465		94	32'-10	4636		80	32'-10	3946	
SLAB TRANSVERSE ENDS, BOTTOM			6c2	-	-	-		-	-	-		30	VARIABLES	797		56	VARIABLES	1486	
SLAB TRANSVERSE, TOP			5d1	107	32'-10	3665		107	34'-0	3795		94	32'-10	3220		80	32'-10	2740	
SLAB TRANSVERSE ENDS, TOP			5d2	-	-	-		-	-	-		30	VARIABLES	553		56	VARIABLES	1032	
SLAB, TRANSVERSE AT ABUTMENT			8e1	18	32'-10	1578		-	-	-		-	-	-		-	-	-	
SLAB, TRANSVERSE AT ABUTMENT			8e2	-	-	-		18	33'-11	1631		18	37'-6	1803		18	45'-4	2179	
SLAB, HAIRPINS, AT ABUTMENT			6e3	72	5'-0	541		72	5'-1	550		72	5'-5	586		72	6'-1	658	
SLAB, DIAGONALS, AT ABUTMENT			6e4	72	5'-11	640		72	5'-11	640		72	5'-11	640		72	5'-11	640	
PIER CAP HOOPS			5h1	54	7'-7	428		54	7'-7	428		54	7'-7	428		72	7'-7	570	
PIER CAP ENDS			8h2	4	14'-5	154		4	14'-5	154		4	14'-5	154		4	14'-5	154	
PIER CAP, BOTTOM LONGITUDINAL			8h3	8	29'-10	638		8	30'-11	661		8	34'-5	736		8	42'-2	901	
PIER CAP, TOP LONGITUDINAL			8h4	4	32'-10	351		4	34'-0	364		4	37'-11	405		4	46'-6	497	
TOP OF SLAB, TRANSVERSE, AT RAIL			5j1	212	8'-6	1880		212	8'-6	1880		212	8'-6	1880		210	8'-6	1862	
WING, VERTICAL			5m1	40	4'-5	185		40	4'-5	185		40	4'-5	185		40	4'-5	185	
WING, HORIZONTAL BACK FACE			5n1	24	6'-8	167		24	6'-8	167		24	6'-8	167		24	6'-8	167	
WING, HORIZONTAL TRAFFIC FACE			5n3	24	6'-9	169		24	6'-9	169		24	6'-9	169		24	6'-9	169	
PAVING BLOCK LIFTING HOOPS			5z1	10	2'-10	30		10	2'-10	30		10	2'-10	30		10	2'-10	30	
SUB TOTAL - LBS.						53,556				53,972				54,242				55,069	
BARRIER RAIL - SEE LIST ON RAIL SHEET J30-41-06						6962				6962				6962				6962	
OPEN RAIL - SEE LIST ON RAIL SHEET J30-44-06						7261				7261				7261				7261	
TOTAL - LBS.						60,518				60,934				61,204				62,031	
WITH MONOLITHIC PIER CAP						60,817				61,233				61,503				62,330	
TOTAL - LBS.						58,947				59,327				59,481				59,909	
SAME AS ABOVE EXCEPT ALL "h" BARS DELETED						59,246				59,626				59,780				60,208	

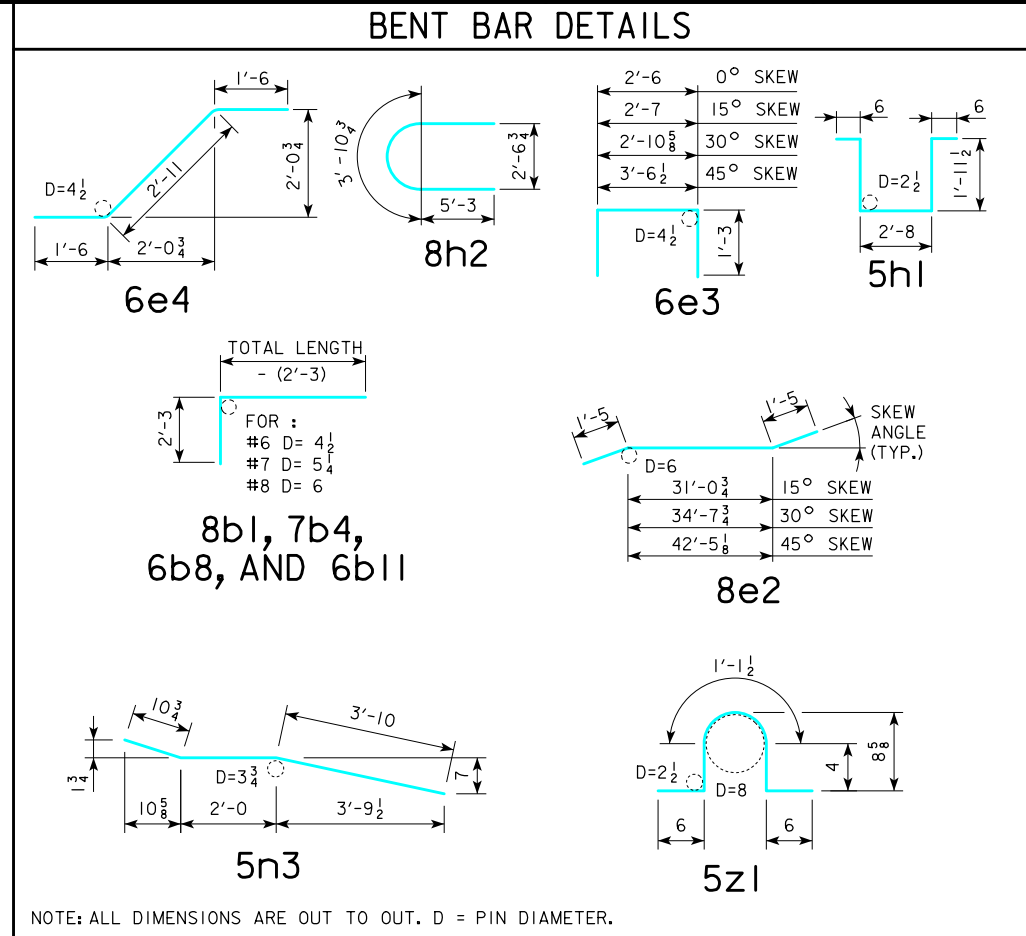

ESTIMATED QUANTITIES FOR SUPERSTRUCTURE - 110' BRIDGE

ITEM	SKEW	WITH MONOLITHIC PIER CAP				WITH NON-MONOLITHIC PIER CAP			
		0°	15°	30°	45°	0°	15°	30°	45°
WITH BARRIER RAIL	*STRUCTURAL CONCRETE (BRIDGE) C.Y.	234.5	235.2	238.0	243.7	229.9	230.5	232.7	237.3
CONCRETE BARRIER OR OPEN RAIL	REINFORCING STEEL LBS.	60,518	60,934	61,204	62,031	58,947	59,327	59,481	59,909
WITH OPEN RAIL	CONCRETE BARRIER OR OPEN RAIL LIN. FT.	242.0	242.2	242.9	244.5	242.0	242.2	242.9	244.5
WITH OPEN RAIL	*STRUCTURAL CONCRETE (BRIDGE) C.Y.	234.3	235.0	237.8	243.5	229.7	230.3	232.5	237.1
WITH OPEN RAIL	REINFORCING STEEL LBS.	60,817	61,233	61,503	62,330	59,246	59,626	59,780	60,208

* INCLUDES 4 WINGS @ 0.68 C.Y. EACH AND 2 TEMPORARY PAVING BLOCKS; EXCLUDES RAIL CONCRETE.

09-2020
LATEST REVISION DATE

APPROVED BY BRIDGE ENGINEER

STANDARD DESIGN - 30' ROADWAY, 3 SPAN BRIDGES

CONTINUOUS CONCRETE SLAB BRIDGES

NOVEMBER, 2006

SUPERSTRUCTURE DETAILS
110'-0 BRIDGE

NON-EPOXY COATED REINFORCING

J30-11B-06

REVISED 07-2009: OPEN RAIL REINF. QTY'S. CHANGED WHICH CHANGED TOTAL REINF. QTY'S.
REVISED 09-2020: UPDATED BRIDGE ENGINEER SIGNATURE. CHANGED PAVING BLOCK LIFTING HOOP BAR MARK. (WAS 5x1).

REVISED 07-2009; OPEN RAIL REINF. QTY'S. CHANGED WHICH CHANGED TOTAL REINF. QTY'S.
REVISED 09-2020; UPDATED BRIDGE ENGINEER SIGNATURE. CHANGED PAVING BLOCK LIFTING HOOP BAR MARK, (WAS 5x1).

BILL OF REINFORCING STEEL FOR SUPERSTRUCTURE - 110' BRIDGE

LOCATION	SKEW	SHAPE	BAR	0°				15°				30°				45°			
				NO.	LENGTH	WEIGHT		NO.	LENGTH	WEIGHT		NO.	LENGTH	WEIGHT		NO.	LENGTH	WEIGHT	
SLAB LONGITUDINAL BOTTOM			8a1	39	24'-3"	2526		39	24'-3"	2526		39	24'-3"	2526		39	24'-3"	2526	
SLAB LONGITUDINAL BOTTOM, AT RAIL			9a2	39	38'-3"	5072		39	38'-3"	5072		39	38'-3"	5072		39	38'-3"	5072	
SLAB LONGITUDINAL BOTTOM			8a3	39	34'-3"	3567		39	34'-3"	3567		39	34'-3"	3567		39	34'-3"	3567	
SLAB LONGITUDINAL BOTTOM, AT RAIL			9a4	40	31'-9"	4318		40	31'-9"	4318		40	31'-9"	4318		40	31'-9"	4318	
SLAB LONGITUDINAL BOTTOM			8a5	20	41'-0"	2190		20	41'-0"	2190		20	41'-0"	2190		20	41'-0"	2190	
SLAB LONGITUDINAL BOTTOM, AT RAIL			9a6	8	39'-3"	1068		8	39'-3"	1068		8	39'-3"	1068		8	39'-3"	1068	
SLAB LONGITUDINAL BOTTOM, AT RAIL			9a7	4	42'-8"	581		4	42'-8"	581		4	42'-8"	581		4	42'-8"	581	
SLAB LONGITUDINAL BOTTOM, AT RAIL			8a8	8	23'-9"	508		8	23'-9"	508		8	23'-9"	508		8	23'-9"	508	
SLAB LONGITUDINAL BOTTOM, AT RAIL			8a9	4	24'-0"	257		4	24'-0"	257		4	24'-0"	257		4	24'-0"	257	
SLAB LONGITUDINAL TOP			8b1	39	13'-0"	1354		39	13'-0"	1354		39	13'-0"	1354		39	13'-0"	1354	
SLAB LONGITUDINAL TOP			10b2	39	28'-4"	4755		39	28'-4"	4755		39	28'-4"	4755		39	28'-4"	4755	
SLAB LONGITUDINAL TOP			10b3	39	25'-7"	4294		39	25'-7"	4294		39	25'-7"	4294		39	25'-7"	4294	
SLAB LONGITUDINAL TOP			7b4	39	21'-5"	1708		39	21'-5"	1708		39	21'-5"	1708		39	21'-5"	1708	
SLAB LONGITUDINAL TOP			10b5	40	26'-6"	4562		40	26'-6"	4562		40	26'-6"	4562		40	26'-6"	4562	
SLAB LONGITUDINAL TOP			6b6	20	27'-4"	822		20	27'-4"	822		20	27'-4"	822		20	27'-4"	822	
SLAB LONGITUDINAL TOP, AT RAIL			6b8	8	26'-9"	322		8	26'-9"	322		8	26'-9"	322		8	26'-9"	322	
SLAB LONGITUDINAL TOP, AT RAIL			10b9	8	27'-3"	939		8	27'-3"	939		8	27'-3"	939		8	27'-3"	939	
SLAB LONGITUDINAL TOP, AT RAIL			6b10	4	21'-0"	127		4	21'-0"	127		4	21'-0"	127		4	21'-0"	127	
SLAB LONGITUDINAL TOP, AT RAIL			6b11	8	30'-3"	364		8	30'-3"	364		8	30'-3"	364		8	30'-3"	364	
SLAB LONGITUDINAL TOP, AT RAIL			10b12	8	19'-6"	672		8	19'-6"	672		8	19'-6"	672		8	19'-6"	672	
SLAB TRANSVERSE, BOTTOM			6c1	107	32'-10"	5277		107	34'-0"	5465		94	32'-10"	4636		80	32'-10"	3946	
SLAB TRANSVERSE ENDS, BOTTOM			6c2	-	-	-		-	-	-		30	VARIABLES	797		56	VARIABLES	1486	
SLAB TRANSVERSE, TOP			5d1	107	32'-10"	3665		107	34'-0"	3795		94	32'-10"	3220		80	32'-10"	2740	
SLAB TRANSVERSE ENDS, TOP			5d2	-	-	-		-	-	-		30	VARIABLES	553		56	VARIABLES	1032	
SLAB, TRANSVERSE AT ABUTMENT			8e1	18	32'-10"	1578		-	-	-		-	-	-		-	-	-	
SLAB, TRANSVERSE AT ABUTMENT			8e2	-	-	-		18	33'-11"	1631		18	37'-6"	1803		18	45'-4"	2179	
SLAB, HAIRPINS, AT ABUTMENT			6e3	72	5'-0"	541		72	5'-1"	550		72	5'-5"	586		72	6'-1"	658	
SLAB, DIAGONALS, AT ABUTMENT			6e4	72	5'-11"	640		72	5'-11"	640		72	5'-11"	640		72	5'-11"	640	
PIER CAP HOOPS			5h1	54	7'-7"	428		54	7'-7"	428		54	7'-7"	428		72	7'-7"	570	
PIER CAP ENDS			8h2	4	14'-5"	154		4	14'-5"	154		4	14'-5"	154		4	14'-5"	154	
PIER CAP, BOTTOM LONGITUDINAL			8h3	8	29'-10"	638		8	30'-11"	661		8	34'-5"	736		8	42'-2"	901	
PIER CAP, TOP LONGITUDINAL			8h4	4	32'-10"	351		4	34'-0"	364		4	37'-11"	405		4	46'-6"	497	
TOP OF SLAB, TRANSVERSE, AT RAIL			5j1	212	8'-6"	1880		212	8'-6"	1880		212	8'-6"	1880		210	8'-6"	1862	
WING, VERTICAL			5m1	40	4'-5"	185		40	4'-5"	185		40	4'-5"	185		40	4'-5"	185	
WING, HORIZONTAL BACK FACE			5n1	24	6'-8"	167		24	6'-8"	167		24	6'-8"	167		24	6'-8"	167	
WING, HORIZONTAL TRAFFIC FACE			5n3	24	6'-9"	169		24	6'-9"	169		24	6'-9"	169		24	6'-9"	169	
** PAVING BLOCK LIFTING HOOPS			5z1	10	2'-10"	30		10	2'-10"	30		10	2'-10"	30		10	2'-10"	30	
SUB TOTAL - LBS.						55,709				56,125				56,395				57,222	
BARRIER RAIL - SEE LIST ON RAIL SHEET J30-41-06						6962				6962				6962				6962	
OPEN RAIL - SEE LIST ON RAIL SHEET J30-44-06						7261				7261				7261				7261	
TOTAL - LBS.																			
				WITH MONOLITHIC PIER CAP	WITH BARRIER RAIL	62,671				63,087				63,357				64,184	
					WITH OPEN RAIL	62,970				63,386				63,656				64,483	
TOTAL - LBS.				WITH NON-MONOLITHIC PIER CAP	WITH BARRIER RAIL	61,100				61,480				61,634				62,062	
SAME AS ABOVE EXCEPT ALL "h" BARS DELETED					WITH OPEN RAIL	61,399				61,779				61,933				62,361	

** BARS MAY BE NON-COATED AT CONTRACTOR'S OPTION.

ESTIMATED QUANTITIES FOR SUPERSTRUCTURE - 110' BRIDGE

ITEM	SKEW	WITH MONOLITHIC PIER CAP				WITH NON-MONOLITHIC PIER CAP			
		0°	15°	30°	45°	0°	15°	30°	45°
WITH *STRUCTURAL CONCRETE (BRIDGE) C.Y.		234.5	235.2	238.0	243.7	229.9	230.5	232.7	237.3
BARRIER RAIL REINFORCING STEEL EPOXY COATED LBS.		62,671	63,087	63,357	64,184	61,100	61,480	61,634	62,062
CONCRETE BARRIER OR OPEN RAIL LIN. FT.		242.0	242.2	242.9	244.5	242.0	242.2	242.9	244.5
WITH *STRUCTURAL CONCRETE (BRIDGE) C.Y.		234.3	235.0	237.8	243.5	229.7	230.3	232.5	237.1
OPEN RAIL REINFORCING STEEL EPOXY COATED LBS.		62,970	63,386	63,656	64,483	61,399	61,779	61,933	62,361

* INCLUDES 4 WINGS @ 0.68 C.Y. EACH AND 2 TEMPORARY PAVING BLOCKS; EXCLUDES RAIL CONCRETE.

BENT BAR DETAILS

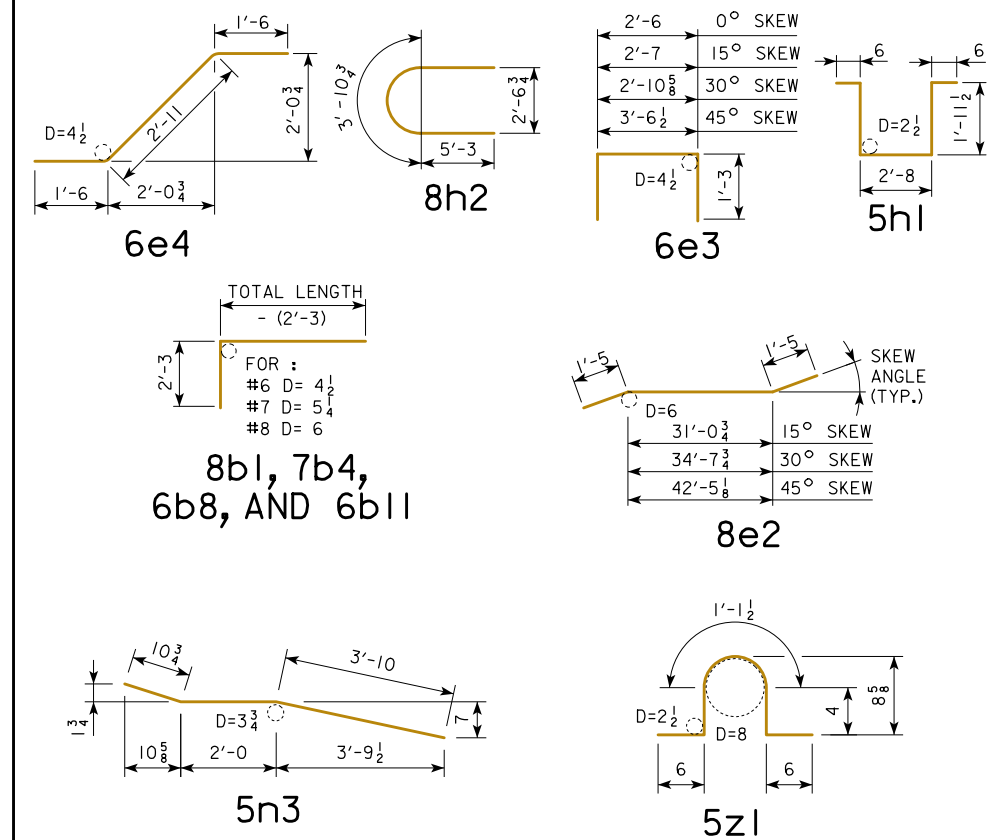

09-2020 LATEST REVISION DATE	 APPROVED BY BRIDGE ENGINEER	 STANDARD DESIGN - 30' ROADWAY, 3 SPAN BRIDGES CONTINUOUS CONCRETE SLAB BRIDGES NOVEMBER, 2006	
		SUPERSTRUCTURE DETAILS 110'-0 BRIDGE	J30-11E-06
		EPOXY COATED REINFORCING	

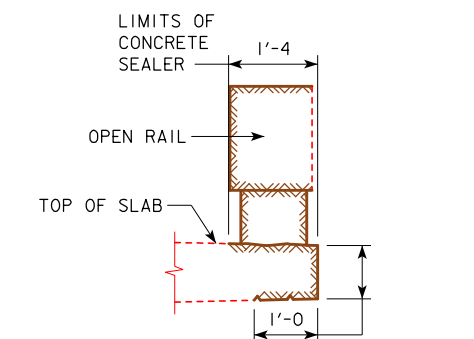
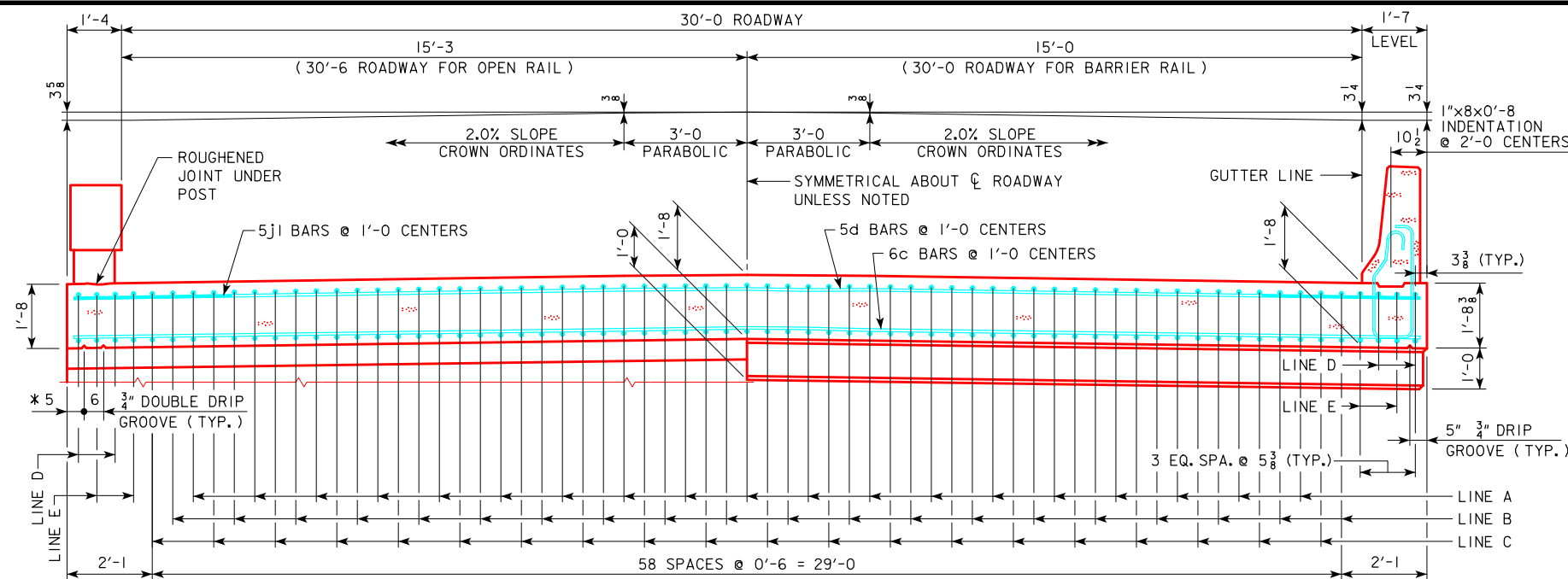

CONCRETE SEALER LIMITS FOR OPEN RAILS

CONCRETE SEALER SHALL BE APPLIED TO BOTH SIDES OF BRIDGE SLAB ON THE TOP, EDGE OF SLAB AND UNDER THE SLAB. THE CONCRETE SEALER SHALL ALSO BE APPLIED TO THE OPEN RAIL ON THE TOP, TRAFFIC FACE SIDE, BOTTOM OF RAIL, AND ON ALL SIDES OF THE OPEN RAIL POSTS.

THE CONCRETE SEALER LIMITS ARE SHOWN IN THE DETAIL AND SHALL APPLY TO THE FULL LENGTH OF BRIDGE. CONCRETE SEALER SHALL BE APPLIED IN ACCORDANCE WITH ARTICLE 2403.03, P, 3 OF THE STANDARD SPECIFICATIONS.

HALF SECTION NEAR ABUTMENT

HALF SECTION NEAR PIER

* NOTE: DOUBLE DRIP GROOVES FOR OPEN RAIL OPTION ONLY.

SLAB CROSS-SECTIONAL AREA FOR OPEN RAIL = 55.28 SQ. FT.

NOTE: TOP LONGITUDINAL REINFORCING STEEL IS TO BE PARALLEL TO AND 2 1/2" CLEAR BELOW TOP OF SLAB. BOTTOM LONGITUDINAL REINFORCING STEEL IS TO BE PARALLEL TO AND 1 1/2" CLEAR ABOVE BOTTOM OF SLAB. REINFORCING STEEL IS TO BE SECURELY WIRED IN PLACE AND ADEQUATELY SUPPORTED ON BAR CHAIRS BEFORE CONCRETE IS POURED. I.M. 451.01 REQUIREMENTS SHALL APPLY FOR BAR CHAIRS.

SLAB CROSS-SECTIONAL AREA FOR BARRIER RAIL = 55.33 SQ. FT.

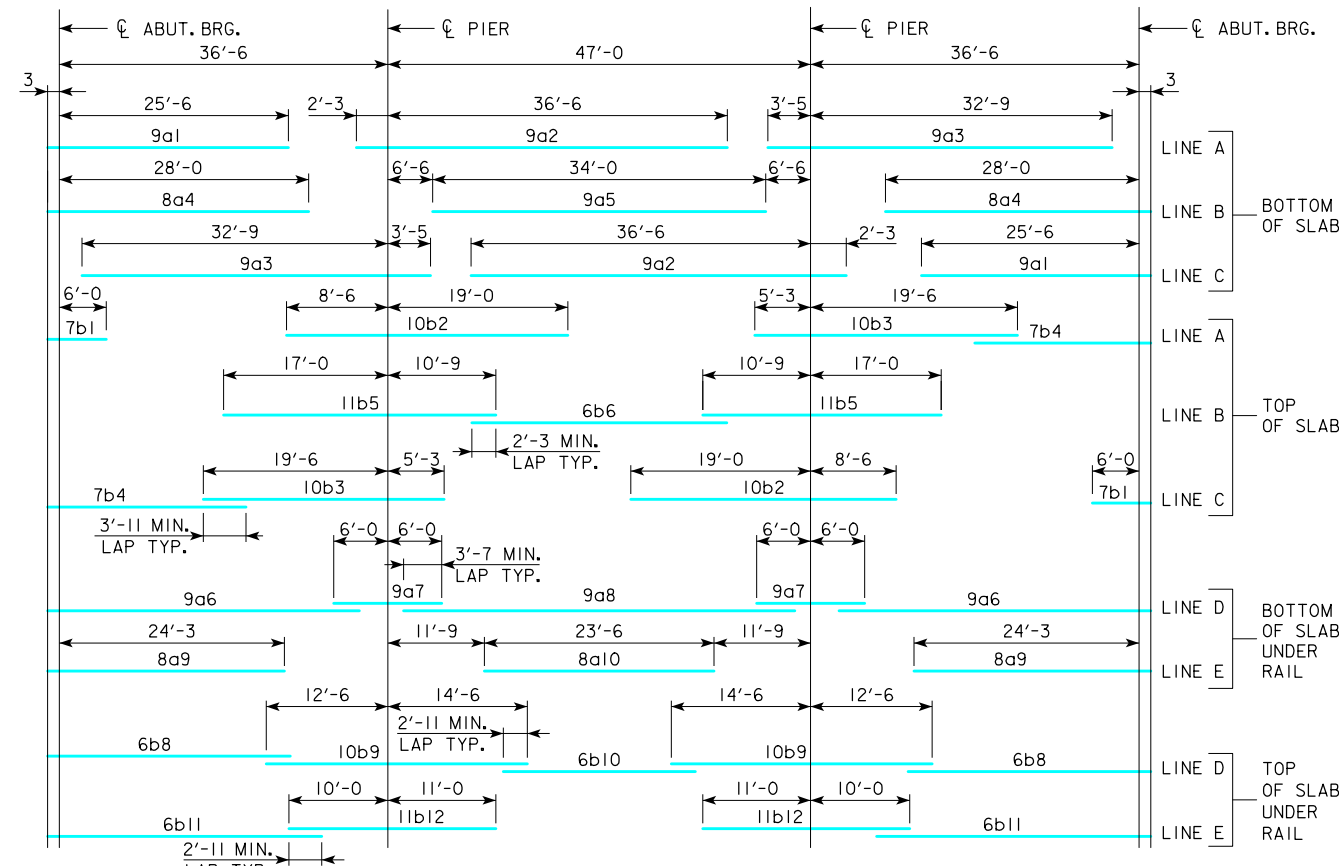

PLACEMENT FOR LONGITUDINAL REINFORCEMENT

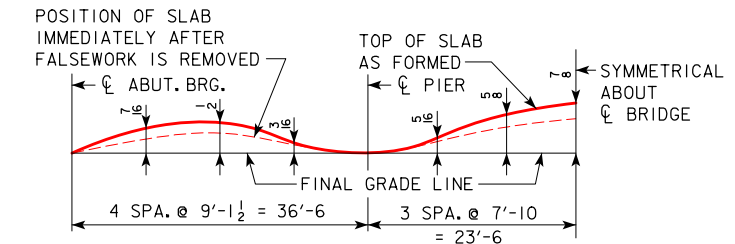

FORM CAMBER DIAGRAM

THIS DIAGRAM SHOWS THE FORM CAMBER REQUIRED TO COMPENSATE FOR THE ANTICIPATED ULTIMATE DEAD LOAD DEFLECTION. THE ABOVE DIMENSIONS DO NOT INCLUDE ANY ALLOWANCE FOR FORM DEFLECTION OR FALSEWORK SETTLEMENT.

REVISED 07-2016; DATE ON SHEET CHANGED TO CORRECT CLERICAL ERROR.
 REVISED 09-2020; UPDATED BRIDGE ENGINEER SIGNATURE.

09-2020 LATEST REVISION DATE APPROVED BY BRIDGE ENGINEER		
	STANDARD DESIGN - 30' ROADWAY, 3 SPAN BRIDGES CONTINUOUS CONCRETE SLAB BRIDGES NOVEMBER, 2006	
	SUPERSTRUCTURE DETAILS 120'-0 BRIDGE	J30-12B-06

NON-EPOXY COATED REINFORCING

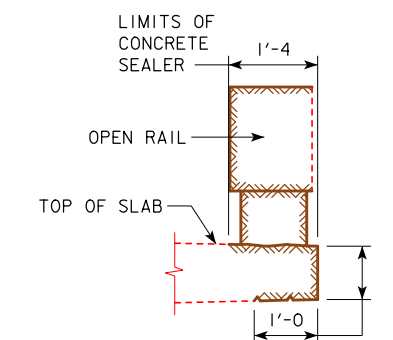
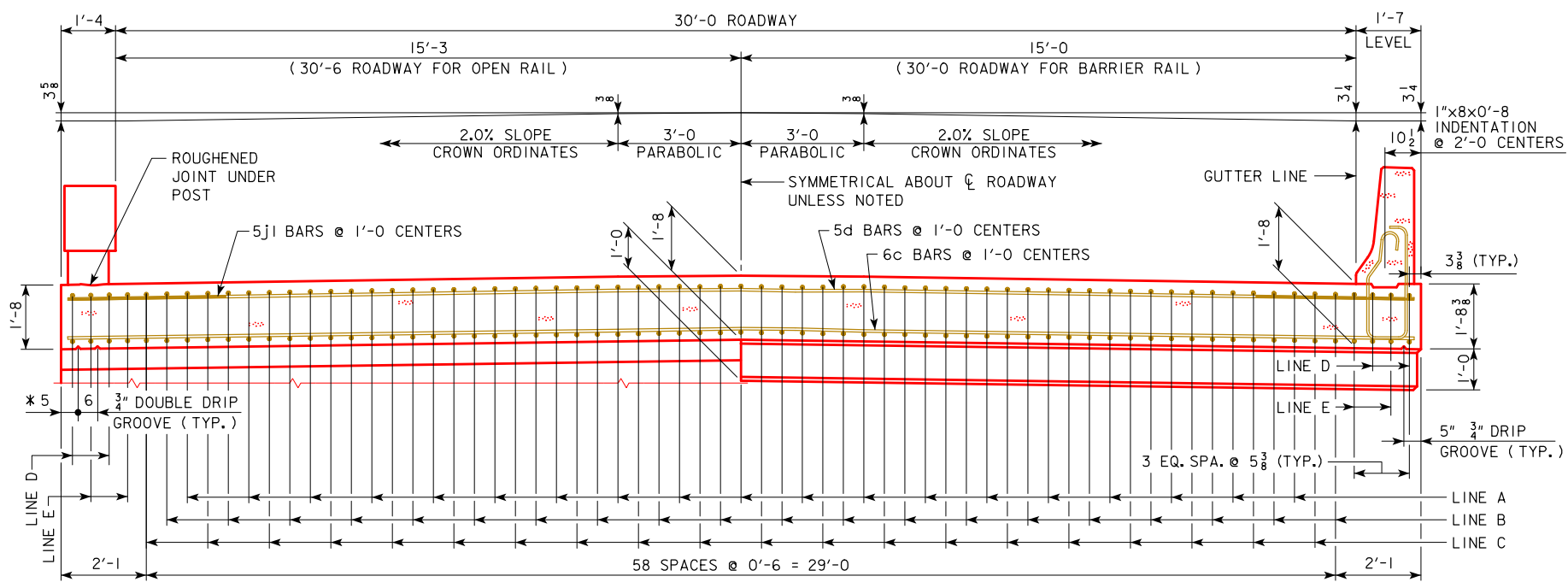

CONCRETE SEALER LIMITS FOR OPEN RAILS

CONCRETE SEALER SHALL BE APPLIED TO BOTH SIDES OF BRIDGE SLAB ON THE TOP, EDGE OF SLAB AND UNDER THE SLAB. THE CONCRETE SEALER SHALL ALSO BE APPLIED TO THE OPEN RAIL ON THE TOP, TRAFFIC FACE SIDE, BOTTOM OF RAIL, AND ON ALL SIDES OF THE OPEN RAIL POSTS.

THE CONCRETE SEALER LIMITS ARE SHOWN IN THE DETAIL AND SHALL APPLY TO THE FULL LENGTH OF BRIDGE. CONCRETE SEALER SHALL BE APPLIED IN ACCORDANCE WITH ARTICLE 2403.03, P, 3 OF THE STANDARD SPECIFICATIONS.

HALF SECTION NEAR ABUTMENT

HALF SECTION NEAR PIER

* NOTE: DOUBLE DRIP GROOVES FOR OPEN RAIL OPTION ONLY.

SLAB CROSS-SECTIONAL AREA FOR OPEN RAIL = 55.28 SQ. FT.

NOTE: TOP LONGITUDINAL REINFORCING STEEL IS TO BE PARALLEL TO AND 2 1/2" CLEAR BELOW TOP OF SLAB. BOTTOM LONGITUDINAL REINFORCING STEEL IS TO BE PARALLEL TO AND 1 1/2" CLEAR ABOVE BOTTOM OF SLAB. REINFORCING STEEL IS TO BE SECURELY WIRED IN PLACE AND ADEQUATELY SUPPORTED ON BAR CHAIRS BEFORE CONCRETE IS POURED. I.M. 451.01 REQUIREMENTS SHALL APPLY FOR BAR CHAIRS.

SLAB CROSS-SECTIONAL AREA FOR BARRIER RAIL = 55.33 SQ. FT.

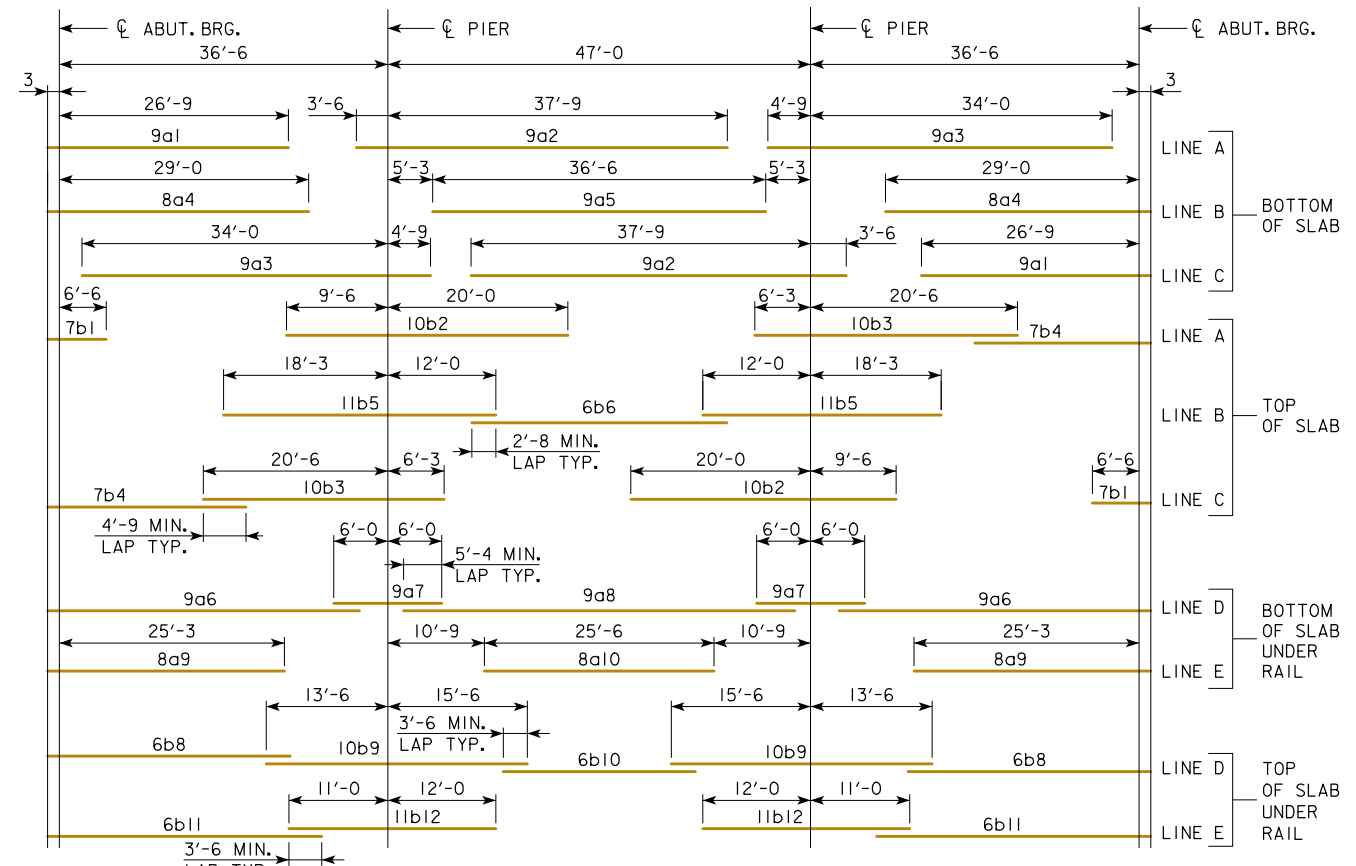

PLACEMENT FOR LONGITUDINAL REINFORCEMENT

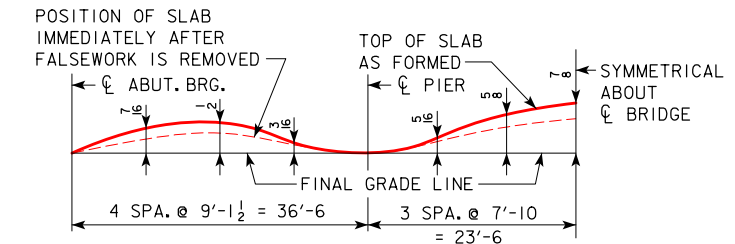

FORM CAMBER DIAGRAM

THIS DIAGRAM SHOWS THE FORM CAMBER REQUIRED TO COMPENSATE FOR THE ANTICIPATED ULTIMATE DEAD LOAD DEFLECTION. THE ABOVE DIMENSIONS DO NOT INCLUDE ANY ALLOWANCE FOR FORM DEFLECTION OR FALSEWORK SETTLEMENT.

REVISED 07-2016; DATE ON SHEET CHANGED TO CORRECT CLERICAL ERROR.
 REVISED 09-2020; UPDATED BRIDGE ENGINEER SIGNATURE.

09-2020 LATEST REVISION DATE		 STANDARD DESIGN - 30' ROADWAY, 3 SPAN BRIDGES CONTINUOUS CONCRETE SLAB BRIDGES NOVEMBER, 2006	
		SUPERSTRUCTURE DETAILS 120'-0 BRIDGE	J30-12E-06
		EPOXY COATED REINFORCING	

BILL OF REINFORCING STEEL FOR SUPERSTRUCTURE - 120' BRIDGE

LOCATION	SKEW	SHAPE	BAR	0°				15°				30°				45°			
				NO.	LENGTH	WEIGHT		NO.	LENGTH	WEIGHT		NO.	LENGTH	WEIGHT		NO.	LENGTH	WEIGHT	
SLAB LONGITUDINAL BOTTOM		————	9a1	39	25'-9"	3415		39	25'-9"	3415		39	25'-9"	3415		39	25'-9"	3415	
SLAB LONGITUDINAL BOTTOM		————	9a2	39	38'-9"	5139		39	38'-9"	5139		39	38'-9"	5139		39	38'-9"	5139	
SLAB LONGITUDINAL BOTTOM		————	9a3	39	36'-2"	4796		39	36'-2"	4796		39	36'-2"	4796		39	36'-2"	4796	
SLAB LONGITUDINAL BOTTOM		————	8a4	40	28'-3"	3018		40	28'-3"	3018		40	28'-3"	3018		40	28'-3"	3018	
SLAB LONGITUDINAL BOTTOM		————	9a5	20	34'-0"	2312		20	34'-0"	2312		20	34'-0"	2312		20	34'-0"	2312	
SLAB LONGITUDINAL BOTTOM, AT RAIL		————	9a6	8	34'-4"	934		8	34'-4"	934		8	34'-4"	934		8	34'-4"	934	
SLAB LONGITUDINAL BOTTOM, AT RAIL		————	9a7	8	12'-0"	327		8	12'-0"	327		8	12'-0"	327		8	12'-0"	327	
SLAB LONGITUDINAL BOTTOM, AT RAIL		————	9a8	4	42'-2"	574		4	42'-2"	574		4	42'-2"	574		4	42'-2"	574	
SLAB LONGITUDINAL BOTTOM, AT RAIL		————	8a9	8	24'-6"	524		8	24'-6"	524		8	24'-6"	524		8	24'-6"	524	
SLAB LONGITUDINAL BOTTOM, AT RAIL		————	8a10	4	23'-6"	251		4	23'-6"	251		4	23'-6"	251		4	23'-6"	251	
SLAB LONGITUDINAL TOP		————	7b1	39	8'-6"	678		39	8'-6"	678		39	8'-6"	678		39	8'-6"	678	
SLAB LONGITUDINAL TOP		————	10b2	39	27'-6"	4615		39	27'-6"	4615		39	27'-6"	4615		39	27'-6"	4615	
SLAB LONGITUDINAL TOP		————	10b3	39	24'-9"	4154		39	24'-9"	4154		39	24'-9"	4154		39	24'-9"	4154	
SLAB LONGITUDINAL TOP		————	7b4	39	23'-5"	1867		39	23'-5"	1867		39	23'-5"	1867		39	23'-5"	1867	
SLAB LONGITUDINAL TOP		————	11b5	40	27'-9"	5898		40	27'-9"	5898		40	27'-9"	5898		40	27'-9"	5898	
SLAB LONGITUDINAL TOP		————	6b6	20	30'-0"	902		20	30'-0"	902		20	30'-0"	902		20	30'-0"	902	
SLAB LONGITUDINAL TOP, AT RAIL		————	6b8	8	29'-5"	354		8	29'-5"	354		8	29'-5"	354		8	29'-5"	354	
SLAB LONGITUDINAL TOP, AT RAIL		————	10b9	8	27'-0"	930		8	27'-0"	930		8	27'-0"	930		8	27'-0"	930	
SLAB LONGITUDINAL TOP, AT RAIL		————	6b10	4	23'-10"	144		4	23'-10"	144		4	23'-10"	144		4	23'-10"	144	
SLAB LONGITUDINAL TOP, AT RAIL		————	6b11	8	31'-11"	384		8	31'-11"	384		8	31'-11"	384		8	31'-11"	384	
SLAB LONGITUDINAL TOP, AT RAIL		————	11b12	8	21'-0"	893		8	21'-0"	893		8	21'-0"	893		8	21'-0"	893	
SLAB TRANSVERSE, BOTTOM		————	6c1	117	32'-10"	5770		117	34'-0"	5975		104	32'-10"	5129		90	32'-10"	4439	
SLAB TRANSVERSE ENDS, BOTTOM		————	6c2	-	-	-		-	-	-		30	VARIABLES	797		56	VARIABLES	1486	
SLAB TRANSVERSE, TOP		————	5d1	117	32'-10"	4007		117	34'-0"	4150		104	32'-10"	3562		90	32'-10"	3083	
SLAB TRANSVERSE ENDS, TOP		————	5d2	-	-	-		-	-	-		30	VARIABLES	553		56	VARIABLES	1032	
SLAB, TRANSVERSE AT ABUTMENT		————	8e1	18	32'-10"	1578		-	-	-		-	-	-		-	-	-	
SLAB, TRANSVERSE AT ABUTMENT		————	8e2	-	-	-		18	33'-11"	1631		18	37'-6"	1803		18	45'-4"	2179	
SLAB, HAIRPINS, AT ABUTMENT		————	6e3	72	5'-0"	541		72	5'-1"	550		72	5'-5"	586		72	6'-1"	658	
SLAB, DIAGONALS, AT ABUTMENT		————	6e4	72	5'-11"	640		72	5'-11"	640		72	5'-11"	640		72	5'-11"	640	
PIER CAP HOOPS		————	5h1	40	7'-10"	327		40	7'-10"	327		60	7'-10"	491		60	7'-10"	491	
PIER CAP ENDS		————	8h2	4	14'-5"	154		4	14'-5"	154		4	14'-5"	154		4	14'-5"	154	
PIER CAP, BOTTOM LONGITUDINAL		————	8h3	8	29'-10"	638		8	30'-11"	661		8	34'-5"	736		8	42'-2"	901	
PIER CAP, TOP LONGITUDINAL		————	8h4	4	32'-10"	351		4	34'-0"	364		4	37'-11"	405		4	46'-6"	497	
TOP OF SLAB, TRANSVERSE, AT RAIL		————	5j1	232	8'-6"	2057		232	8'-6"	2057		232	8'-6"	2057		230	8'-6"	2040	
WING, VERTICAL		————	5m1	40	4'-5"	185		40	4'-5"	185		40	4'-5"	185		40	4'-5"	185	
WING, HORIZONTAL BACK FACE		————	5n1	24	6'-8"	167		24	6'-8"	167		24	6'-8"	167		24	6'-8"	167	
WING, HORIZONTAL TRAFFIC FACE		————	5n3	24	6'-9"	169		24	6'-9"	169		24	6'-9"	169		24	6'-9"	169	
PAVING BLOCK LIFTING HOOPS		————	5z1	10	2'-10"	30		10	2'-10"	30		10	2'-10"	30		10	2'-10"	30	
SUB TOTAL - LBS.						58,723				59,169				59,573				60,260	
BARRIER RAIL - SEE LIST ON RAIL SHEET J30-41-06						7536				7536				7536				7536	
OPEN RAIL - SEE LIST ON RAIL SHEET J30-44-06						8061				8061				8061				8061	
TOTAL - LBS.																			
				WITH MONOLITHIC PIER CAP															
				WITH BARRIER RAIL															
				WITH OPEN RAIL															
						66,259				66,705				67,109				67,796	
						66,784				67,230				67,634				68,321	
TOTAL - LBS.				WITH NON-MONOLITHIC PIER CAP															
				WITH BARRIER RAIL															
				WITH OPEN RAIL															
						64,789				65,199				65,323				65,753	
						65,314				65,724				65,848				66,278	
SAME AS ABOVE EXCEPT ALL "h" BARS DELETED						65,314				65,724				65,848				66,278	

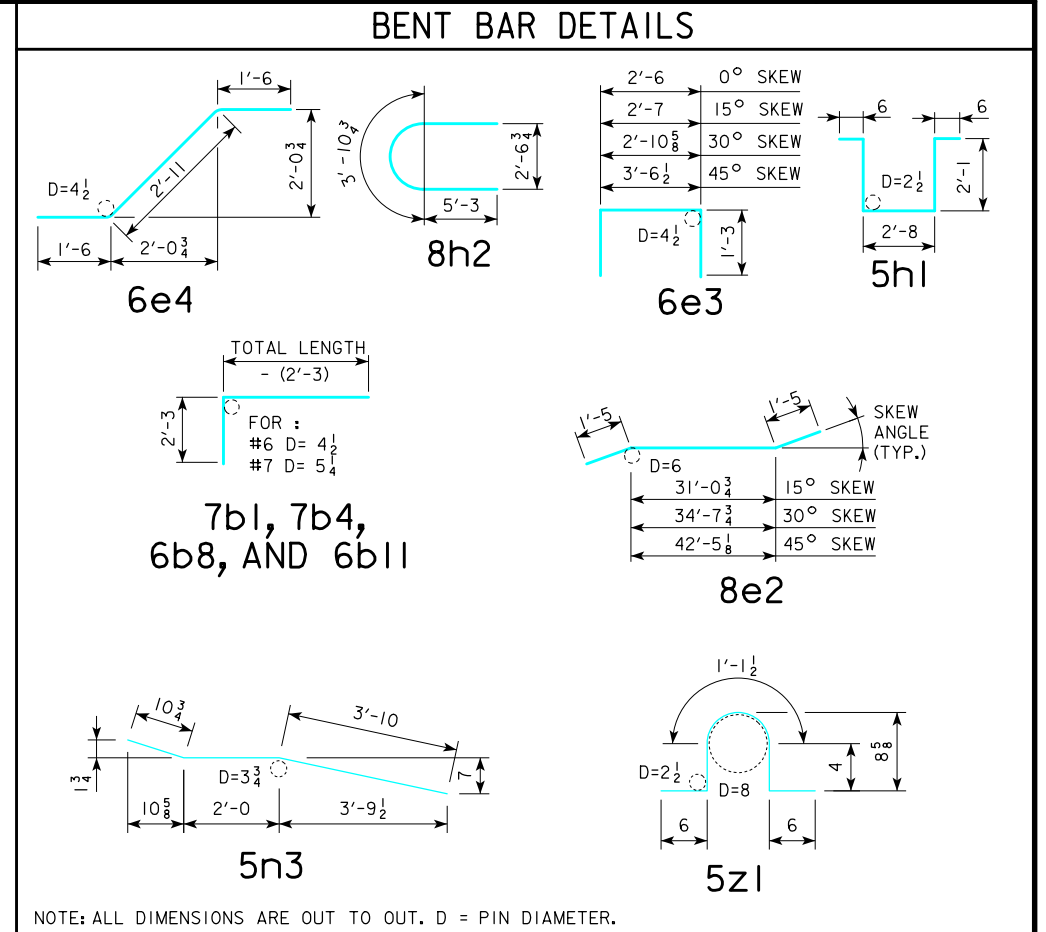

ESTIMATED QUANTITIES FOR SUPERSTRUCTURE - 120' BRIDGE

ITEM	SKEW	WITH MONOLITHIC PIER CAP				WITH NON-MONOLITHIC PIER CAP			
		0°	15°	30°	45°	0°	15°	30°	45°
WITH *STRUCTURAL CONCRETE (BRIDGE) C.Y.		271.4	272.1	274.8	280.4	266.8	267.4	269.6	274.1
BARRIER RAIL REINFORCING STEEL LBS.		66,259	66,705	67,109	67,796	64,789	65,199	65,323	65,753
CONCRETE BARRIER OR OPEN RAIL LIN. FT.		262.0	262.2	262.9	264.5	262.0	262.2	262.9	264.5
WITH *STRUCTURAL CONCRETE (BRIDGE) C.Y.		271.2	271.9	274.6	280.2	266.6	267.1	269.3	273.8
OPEN RAIL REINFORCING STEEL LBS.		66,784	67,230	67,634	68,321	65,314	65,724	65,848	66,278

* INCLUDES 4 WINGS @ 0.68 C.Y. EACH AND 2 TEMPORARY PAVING BLOCKS; EXCLUDES RAIL CONCRETE.

REVISED 07-2009: OPEN RAIL REINF. QTY'S. CHANGED WHICH CHANGED TOTAL REINF. QTY'S.
REVISED 09-2020: UPDATED BRIDGE ENGINEER SIGNATURE. CHANGED PAVING BLOCK LIFTING HOOP BAR MARK, (WAS 5x1).

09-2020 LATEST REVISION DATE	 APPROVED BY BRIDGE ENGINEER	
		STANDARD DESIGN - 30' ROADWAY, 3 SPAN BRIDGES CONTINUOUS CONCRETE SLAB BRIDGES NOVEMBER, 2006
		<div style="text-align: center;"> SUPERSTRUCTURE DETAILS 120'-0 BRIDGE </div> <div style="text-align: right;"> J30-13B-06 </div>

NON-EPOXY COATED REINFORCING

REVISED 07-2009: OPEN RAIL REINF. QTY'S. CHANGED WHICH CHANGED TOTAL REINF. QTY'S.
REVISED 09-2020: UPDATED BRIDGE ENGINEER SIGNATURE. CHANGED PAVING BLOCK LIFTING HOOP BAR MARK, (WAS 5x1).

BILL OF REINFORCING STEEL FOR SUPERSTRUCTURE - 120' BRIDGE

LOCATION	SKEW	SHAPE	BAR	0°				15°				30°				45°			
				NO.	LENGTH	WEIGHT		NO.	LENGTH	WEIGHT		NO.	LENGTH	WEIGHT		NO.	LENGTH	WEIGHT	
SLAB LONGITUDINAL BOTTOM			9a1	39	27'-0	3581		39	27'-0	3581		39	27'-0	3581		39	27'-0	3581	
SLAB LONGITUDINAL BOTTOM			9a2	39	41'-3	5470		39	41'-3	5470		39	41'-3	5470		39	41'-3	5470	
SLAB LONGITUDINAL BOTTOM			9a3	39	38'-9	5139		39	38'-9	5139		39	38'-9	5139		39	38'-9	5139	
SLAB LONGITUDINAL BOTTOM			8a4	40	29'-3	3124		40	29'-3	3124		40	29'-3	3124		40	29'-3	3124	
SLAB LONGITUDINAL BOTTOM			9a5	20	36'-6	2482		20	36'-6	2482		20	36'-6	2482		20	36'-6	2482	
SLAB LONGITUDINAL BOTTOM, AT RAIL			9a6	8	36'-1	982		8	36'-1	982		8	36'-1	982		8	36'-1	982	
SLAB LONGITUDINAL BOTTOM, AT RAIL			9a7	8	12'-0	327		8	12'-0	327		8	12'-0	327		8	12'-0	327	
SLAB LONGITUDINAL BOTTOM, AT RAIL			9a8	4	45'-8	622		4	45'-8	622		4	45'-8	622		4	45'-8	622	
SLAB LONGITUDINAL BOTTOM, AT RAIL			8a9	8	25'-6	545		8	25'-6	545		8	25'-6	545		8	25'-6	545	
SLAB LONGITUDINAL BOTTOM, AT RAIL			8a10	4	25'-6	273		4	25'-6	273		4	25'-6	273		4	25'-6	273	
SLAB LONGITUDINAL TOP			7b1	39	9'-0	718		39	9'-0	718		39	9'-0	718		39	9'-0	718	
SLAB LONGITUDINAL TOP			10b2	39	29'-6	4951		39	29'-6	4951		39	29'-6	4951		39	29'-6	4951	
SLAB LONGITUDINAL TOP			10b3	39	26'-9	4490		39	26'-9	4490		39	26'-9	4490		39	26'-9	4490	
SLAB LONGITUDINAL TOP			7b4	39	23'-3	1854		39	23'-3	1854		39	23'-3	1854		39	23'-3	1854	
SLAB LONGITUDINAL TOP			11b5	40	30'-3	6429		40	30'-3	6429		40	30'-3	6429		40	30'-3	6429	
SLAB LONGITUDINAL TOP			6b6	20	28'-4	852		20	28'-4	852		20	28'-4	852		20	28'-4	852	
SLAB LONGITUDINAL TOP, AT RAIL			6b8	8	29'-0	349		8	29'-0	349		8	29'-0	349		8	29'-0	349	
SLAB LONGITUDINAL TOP, AT RAIL			10b9	8	29'-0	999		8	29'-0	999		8	29'-0	999		8	29'-0	999	
SLAB LONGITUDINAL TOP, AT RAIL			6b10	4	23'-0	139		4	23'-0	139		4	23'-0	139		4	23'-0	139	
SLAB LONGITUDINAL TOP, AT RAIL			6b11	8	31'-6	379		8	31'-6	379		8	31'-6	379		8	31'-6	379	
SLAB LONGITUDINAL TOP, AT RAIL			11b12	8	23'-0	978		8	23'-0	978		8	23'-0	978		8	23'-0	978	
SLAB TRANSVERSE, BOTTOM			6c1	117	32'-10	5770		117	34'-0	5975		104	32'-10	5129		90	32'-10	4439	
SLAB TRANSVERSE ENDS, BOTTOM			6c2	-	-	-		-	-	-		30	VARIES	797		56	VARIES	1486	
SLAB TRANSVERSE, TOP			5d1	117	32'-10	4007		117	34'-0	4150		104	32'-10	3562		90	32'-10	3083	
SLAB TRANSVERSE ENDS, TOP			5d2	-	-	-		-	-	-		30	VARIES	553		56	VARIES	1032	
SLAB, TRANSVERSE AT ABUTMENT			8e1	18	32'-10	1578		-	-	-		-	-	-		-	-	-	
SLAB, TRANSVERSE AT ABUTMENT			8e2	-	-	-		18	33'-11	1631		18	37'-6	1803		18	45'-4	2179	
SLAB, HAIRPINS, AT ABUTMENT			6e3	72	5'-0	541		72	5'-1	550		72	5'-5	586		72	6'-1	658	
SLAB, DIAGONALS, AT ABUTMENT			6e4	72	5'-11	640		72	5'-11	640		72	5'-11	640		72	5'-11	640	
PIER CAP HOOPS			5h1	40	7'-10	327		40	7'-10	327		60	7'-10	491		60	7'-10	491	
PIER CAP ENDS			8h2	4	14'-5	154		4	14'-5	154		4	14'-5	154		4	14'-5	154	
PIER CAP, BOTTOM LONGITUDINAL			8h3	8	29'-10	638		8	30'-11	661		8	34'-5	736		8	42'-2	901	
PIER CAP, TOP LONGITUDINAL			8h4	4	32'-10	351		4	34'-0	364		4	37'-11	405		4	46'-6	497	
TOP OF SLAB, TRANSVERSE, AT RAIL			5j1	232	8'-6	2057		232	8'-6	2057		232	8'-6	2057		230	8'-6	2040	
WING, VERTICAL			5m1	40	4'-5	185		40	4'-5	185		40	4'-5	185		40	4'-5	185	
WING, HORIZONTAL BACK FACE			5n1	24	6'-8	167		24	6'-8	167		24	6'-8	167		24	6'-8	167	
WING, HORIZONTAL TRAFFIC FACE			5n3	24	6'-9	169		24	6'-9	169		24	6'-9	169		24	6'-9	169	
** PAVING BLOCK LIFTING HOOPS			5z1	10	2'-10	30		10	2'-10	30		10	2'-10	30		10	2'-10	30	
SUB TOTAL - LBS.						61,297			61,743			62,147			62,834				
BARRIER RAIL - SEE LIST ON RAIL SHEET J30-41-06						7536			7536			7536			7536				
OPEN RAIL - SEE LIST ON RAIL SHEET J30-44-06						8061			8061			8061			8061				
TOTAL - LBS.						68,833			69,279			69,683			70,370				
				WITH MONOLITHIC PIER CAP															
				WITH BARRIER RAIL		68,833			69,279			69,683			70,370				
				WITH OPEN RAIL		69,358			69,804			70,208			70,895				
TOTAL - LBS.						67,363			67,773			67,897			68,327				
				WITH NON-MONOLITHIC PIER CAP															
				WITH BARRIER RAIL		67,363			67,773			67,897			68,327				
				WITH OPEN RAIL		67,888			68,298			68,422			68,852				
SAME AS ABOVE EXCEPT ALL "h" BARS DELETED						67,888			68,298			68,422			68,852				

** BARS MAY BE NON-COATED AT CONTRACTOR'S OPTION.

ESTIMATED QUANTITIES FOR SUPERSTRUCTURE - 120' BRIDGE

ITEM	SKEW	WITH MONOLITHIC PIER CAP				WITH NON-MONOLITHIC PIER CAP			
		0°	15°	30°	45°	0°	15°	30°	45°
WITH *STRUCTURAL CONCRETE (BRIDGE) C.Y.		271.4	272.1	274.8	280.4	266.8	267.4	269.6	274.1
BARRIER RAIL REINFORCING STEEL EPOXY COATED LBS.		68,833	69,279	69,683	70,370	67,363	67,773	67,897	68,327
CONCRETE BARRIER OR OPEN RAIL LIN. FT.		262.0	262.2	262.9	264.5	262.0	262.2	262.9	264.5
WITH *STRUCTURAL CONCRETE (BRIDGE) C.Y.		271.2	271.9	274.6	280.2	266.6	267.1	269.3	273.8
OPEN RAIL REINFORCING STEEL EPOXY COATED LBS.		69,358	69,804	70,208	70,895	67,888	68,298	68,422	68,852

* INCLUDES 4 WINGS @ 0.68 C.Y. EACH AND 2 TEMPORARY PAVING BLOCKS; EXCLUDES RAIL CONCRETE.

BENT BAR DETAILS

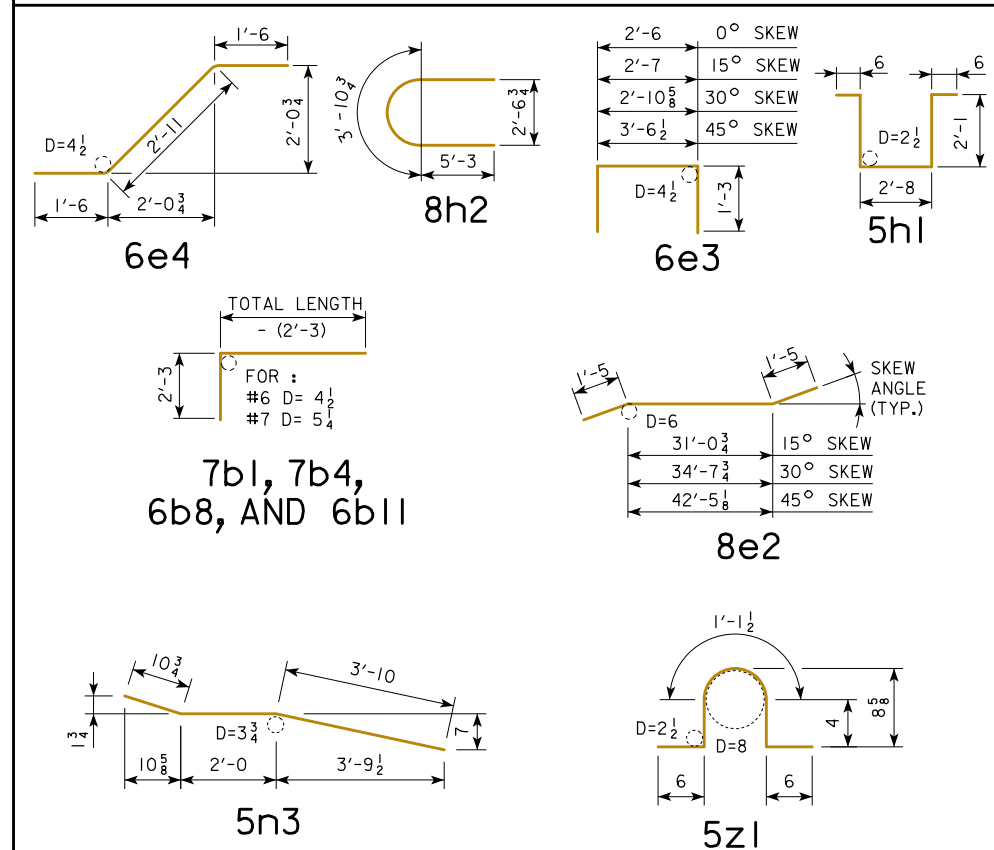

NOTE: ALL DIMENSIONS ARE OUT TO OUT. D = PIN DIAMETER.

09-2020 LATEST REVISION DATE	 APPROVED BY BRIDGE ENGINEER	 STANDARD DESIGN - 30' ROADWAY, 3 SPAN BRIDGES CONTINUOUS CONCRETE SLAB BRIDGES NOVEMBER, 2006	
		SUPERSTRUCTURE DETAILS 120'-0 BRIDGE	J30-13E-06
		EPOXY COATED REINFORCING	

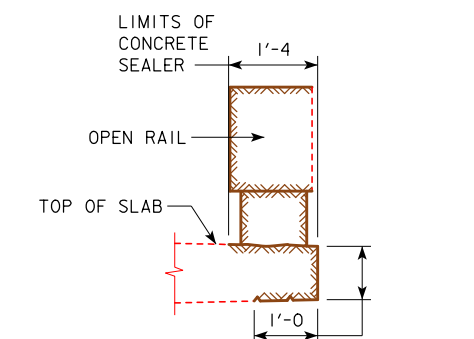
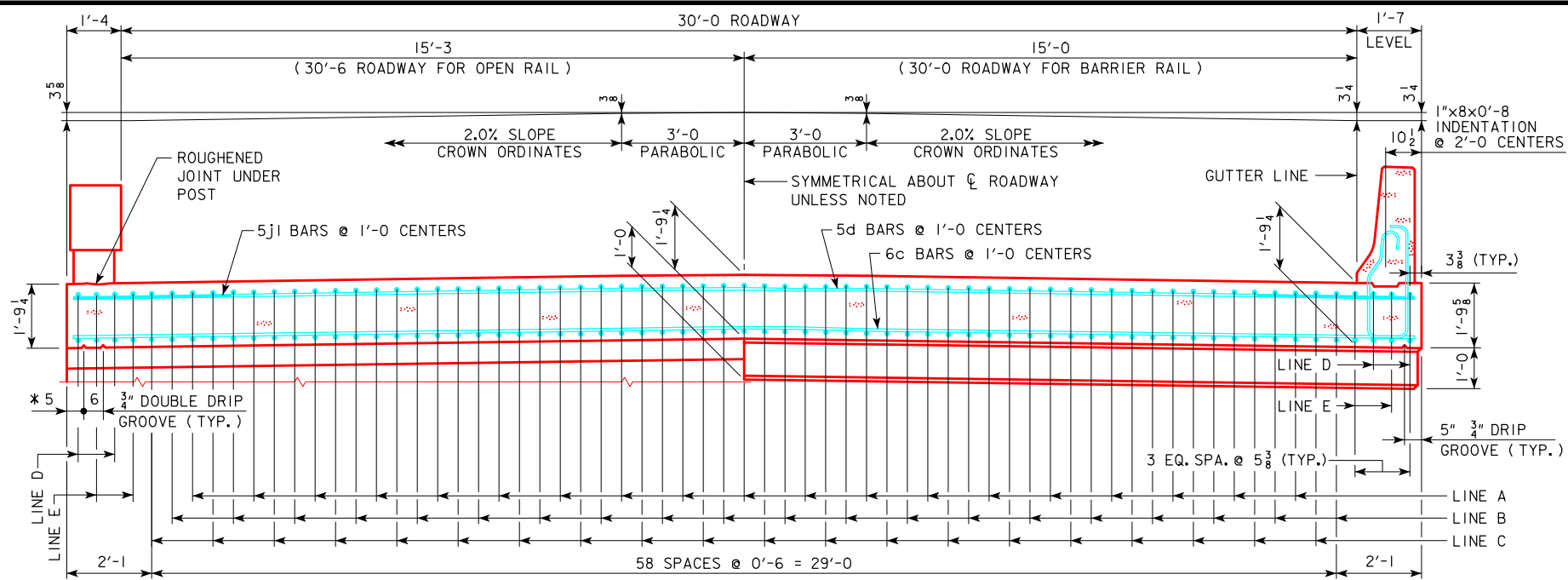

CONCRETE SEALER LIMITS FOR OPEN RAILS

CONCRETE SEALER SHALL BE APPLIED TO BOTH SIDES OF BRIDGE SLAB ON THE TOP, EDGE OF SLAB AND UNDER THE SLAB. THE CONCRETE SEALER SHALL ALSO BE APPLIED TO THE OPEN RAIL ON THE TOP, TRAFFIC FACE SIDE, BOTTOM OF RAIL, AND ON ALL SIDES OF THE OPEN RAIL POSTS.

THE CONCRETE SEALER LIMITS ARE SHOWN IN THE DETAIL AND SHALL APPLY TO THE FULL LENGTH OF BRIDGE. CONCRETE SEALER SHALL BE APPLIED IN ACCORDANCE WITH ARTICLE 2403.03, P, 3 OF THE STANDARD SPECIFICATIONS.

HALF SECTION NEAR ABUTMENT

HALF SECTION NEAR PIER

* NOTE: DOUBLE DRIP GROOVES FOR OPEN RAIL OPTION ONLY.

SLAB CROSS-SECTIONAL AREA FOR OPEN RAIL = 58.74 SQ. FT.

NOTE: TOP LONGITUDINAL REINFORCING STEEL IS TO BE PARALLEL TO AND 2 1/2" CLEAR BELOW TOP OF SLAB. BOTTOM LONGITUDINAL REINFORCING STEEL IS TO BE PARALLEL TO AND 1 1/2" CLEAR ABOVE BOTTOM OF SLAB. REINFORCING STEEL IS TO BE SECURELY WIRED IN PLACE AND ADEQUATELY SUPPORTED ON BAR CHAIRS BEFORE CONCRETE IS POURED. I.M. 451.01 REQUIREMENTS SHALL APPLY FOR BAR CHAIRS.

SLAB CROSS-SECTIONAL AREA FOR BARRIER RAIL = 58.79 SQ. FT.

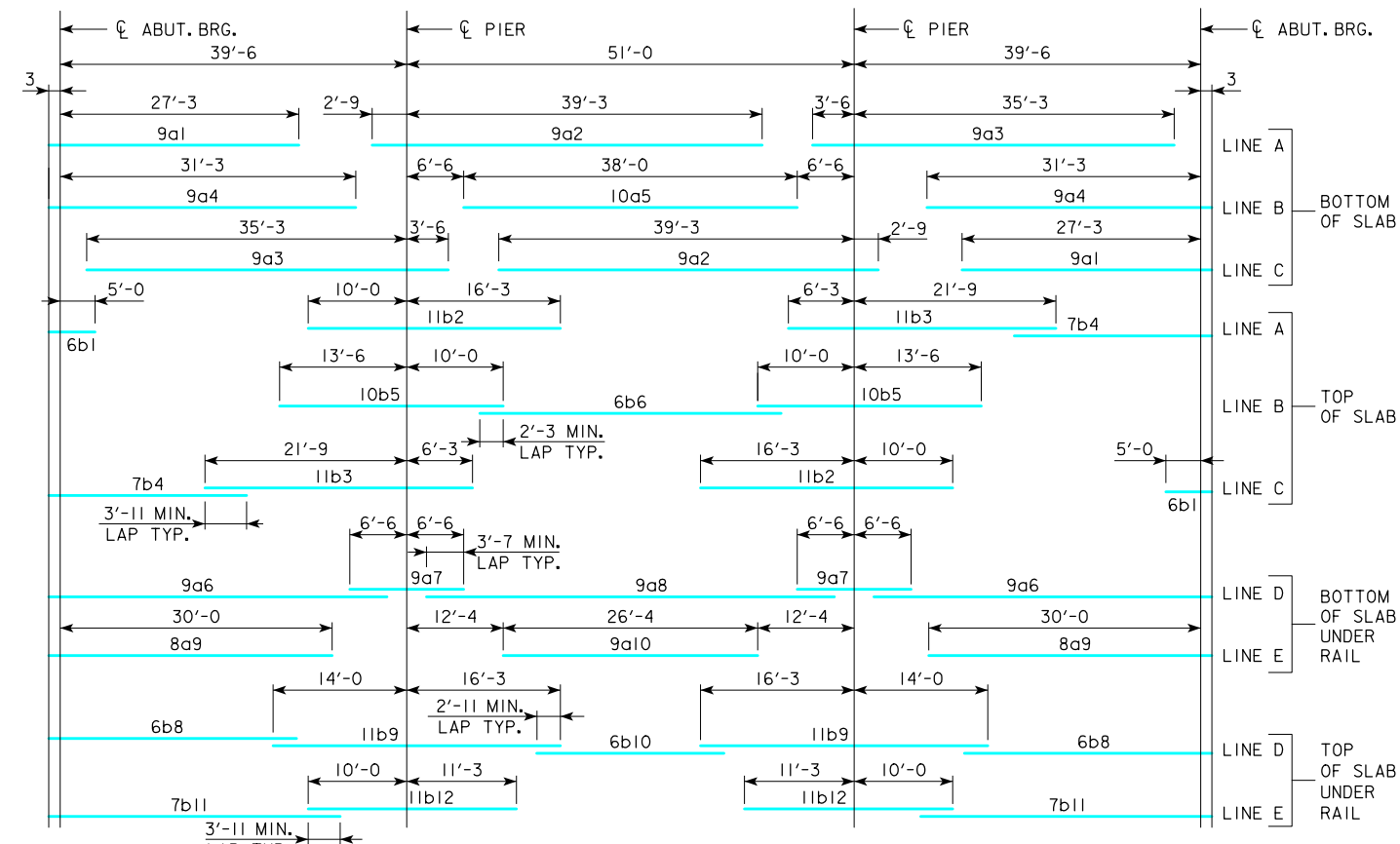

PLACEMENT FOR LONGITUDINAL REINFORCEMENT

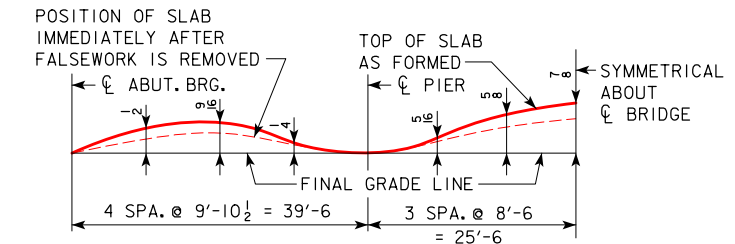

FORM CAMBER DIAGRAM

THIS DIAGRAM SHOWS THE FORM CAMBER REQUIRED TO COMPENSATE FOR THE ANTICIPATED ULTIMATE DEAD LOAD DEFLECTION. THE ABOVE DIMENSIONS DO NOT INCLUDE ANY ALLOWANCE FOR FORM DEFLECTION OR FALSEWORK SETTLEMENT.

REVISED 07-2016; DATE ON SHEET CHANGED TO CORRECT CLERICAL ERROR.
 REVISED 09-2020; UPDATED BRIDGE ENGINEER SIGNATURE.

09-2020 LATEST REVISION DATE APPROVED BY BRIDGE ENGINEER	 STANDARD DESIGN - 30' ROADWAY, 3 SPAN BRIDGES CONTINUOUS CONCRETE SLAB BRIDGES NOVEMBER, 2006	
	SUPERSTRUCTURE DETAILS 130'-0 BRIDGE	J30-14B-06
	NON-EPOXY COATED REINFORCING	

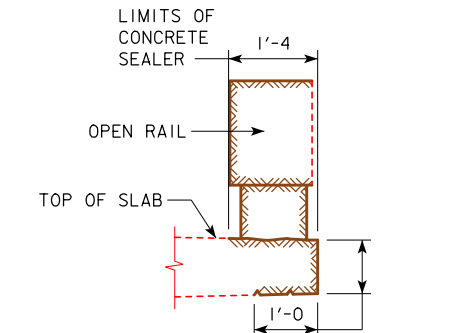
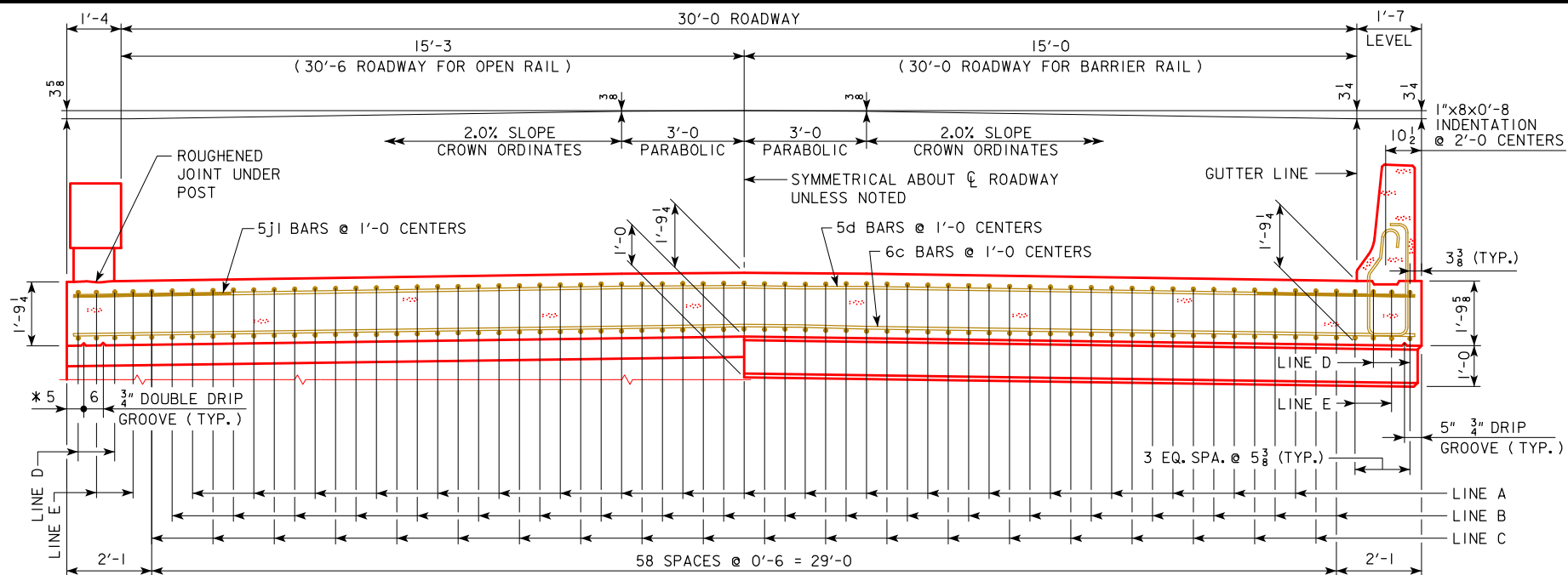

CONCRETE SEALER LIMITS FOR OPEN RAILS

CONCRETE SEALER SHALL BE APPLIED TO BOTH SIDES OF BRIDGE SLAB ON THE TOP, EDGE OF SLAB AND UNDER THE SLAB. THE CONCRETE SEALER SHALL ALSO BE APPLIED TO THE OPEN RAIL ON THE TOP, TRAFFIC FACE SIDE, BOTTOM OF RAIL, AND ON ALL SIDES OF THE OPEN RAIL POSTS.

THE CONCRETE SEALER LIMITS ARE SHOWN IN THE DETAIL AND SHALL APPLY TO THE FULL LENGTH OF BRIDGE. CONCRETE SEALER SHALL BE APPLIED IN ACCORDANCE WITH ARTICLE 2403.03, P, 3 OF THE STANDARD SPECIFICATIONS.

HALF SECTION NEAR ABUTMENT

HALF SECTION NEAR PIER

* NOTE: DOUBLE DRIP GROOVES FOR OPEN RAIL OPTION ONLY.

SLAB CROSS-SECTIONAL AREA FOR OPEN RAIL = 58.74 SQ. FT.

NOTE: TOP LONGITUDINAL REINFORCING STEEL IS TO BE PARALLEL TO AND 2 1/2" CLEAR BELOW TOP OF SLAB. BOTTOM LONGITUDINAL REINFORCING STEEL IS TO BE PARALLEL TO AND 1 1/2" CLEAR ABOVE BOTTOM OF SLAB. REINFORCING STEEL IS TO BE SECURELY WIRED IN PLACE AND ADEQUATELY SUPPORTED ON BAR CHAIRS BEFORE CONCRETE IS POURED. I.M. 451.01 REQUIREMENTS SHALL APPLY FOR BAR CHAIRS.

SLAB CROSS-SECTIONAL AREA FOR BARRIER RAIL = 58.79 SQ. FT.

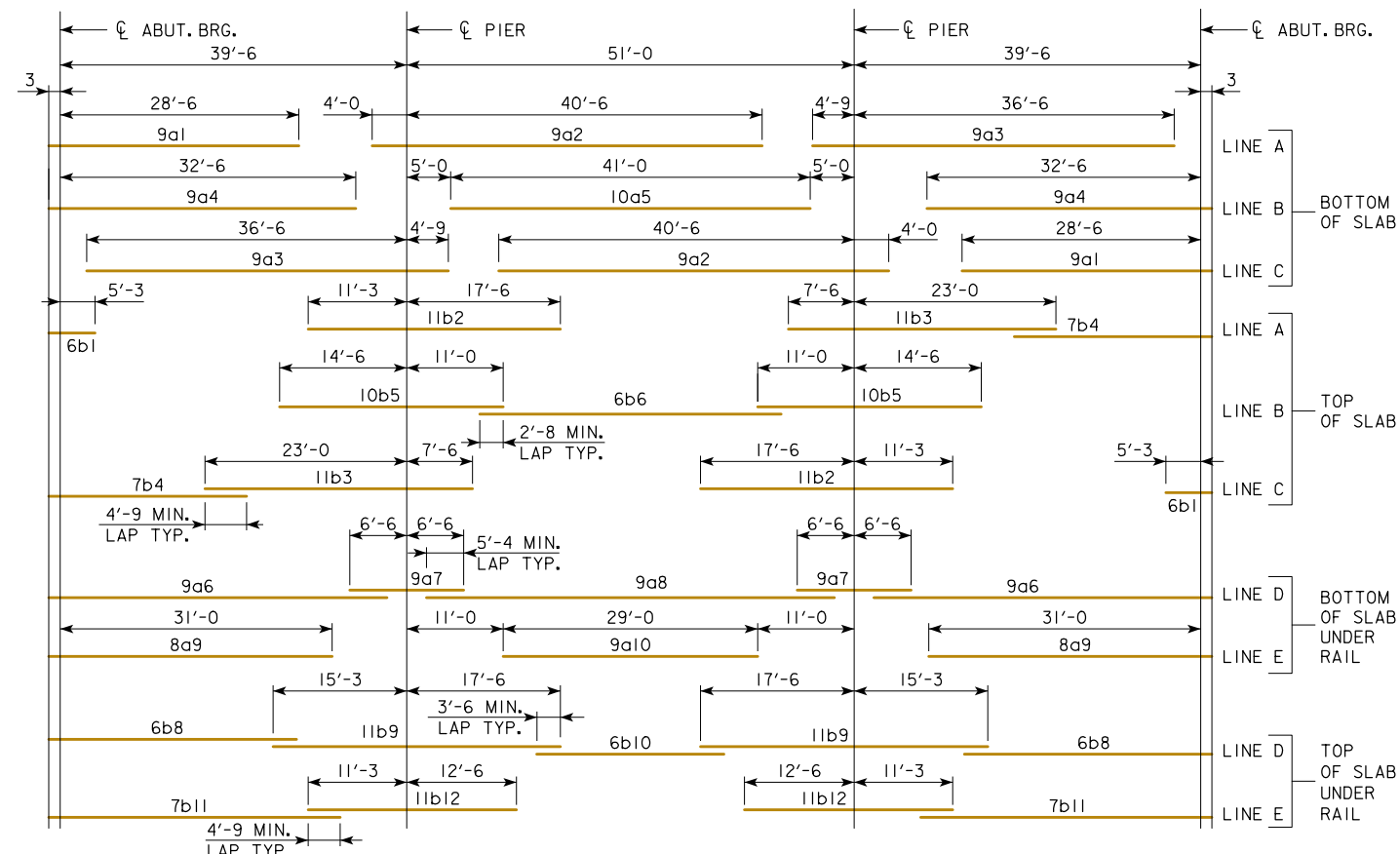

PLACEMENT FOR LONGITUDINAL REINFORCEMENT

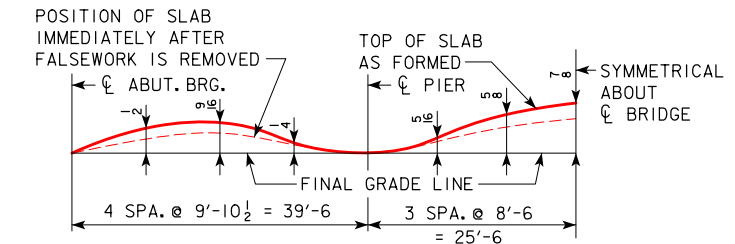

FORM CAMBER DIAGRAM

THIS DIAGRAM SHOWS THE FORM CAMBER REQUIRED TO COMPENSATE FOR THE ANTICIPATED ULTIMATE DEAD LOAD DEFLECTION. THE ABOVE DIMENSIONS DO NOT INCLUDE ANY ALLOWANCE FOR FORM DEFLECTION OR FALSEWORK SETTLEMENT.

REVISED 07-2016; DATE ON SHEET CHANGED TO CORRECT CLERICAL ERROR.
REVISED 09-2020; UPDATED BRIDGE ENGINEER SIGNATURE.

09-2020 LATEST REVISION DATE APPROVED BY BRIDGE ENGINEER	 STANDARD DESIGN - 30' ROADWAY, 3 SPAN BRIDGES CONTINUOUS CONCRETE SLAB BRIDGES NOVEMBER, 2006	
	SUPERSTRUCTURE DETAILS 130'-0 BRIDGE	J30-14E-06
	EPOXY COATED REINFORCING	

REVISED 07-2009; OPEN RAIL REINF. QTY'S. CHANGED WHICH CHANGED TOTAL REINF. QTY'S.
REVISED 09-2020; UPDATED BRIDGE ENGINEER SIGNATURE. CHANGED PAVING BLOCK LIFTING HOOP BAR MARK, (WAS 5X1).

BILL OF REINFORCING STEEL FOR SUPERSTRUCTURE - 130' BRIDGE

LOCATION	SKEW	SHAPE	0°				15°				30°				45°			
			BAR NO.	LENGTH	WEIGHT	NO.	LENGTH	WEIGHT	NO.	LENGTH	WEIGHT	NO.	LENGTH	WEIGHT	NO.	LENGTH	WEIGHT	
SLAB LONGITUDINAL BOTTOM		9a1	39	27'-6"	3647	39	27'-6"	3647	39	27'-6"	3647	39	27'-6"	3647				
SLAB LONGITUDINAL BOTTOM, AT RAIL		9a2	39	42'-0"	5570	39	42'-0"	5570	39	42'-0"	5570	39	42'-0"	5570				
SLAB LONGITUDINAL BOTTOM, AT RAIL		9a3	39	38'-9"	5139	39	38'-9"	5139	39	38'-9"	5139	39	38'-9"	5139				
SLAB LONGITUDINAL BOTTOM, AT RAIL		9a4	40	31'-6"	4284	40	31'-6"	4284	40	31'-6"	4284	40	31'-6"	4284				
SLAB LONGITUDINAL BOTTOM, AT RAIL		10a5	20	38'-0"	3271	20	38'-0"	3271	20	38'-0"	3271	20	38'-0"	3271				
SLAB LONGITUDINAL BOTTOM, AT RAIL		9a6	8	36'-10"	1002	8	36'-10"	1002	8	36'-10"	1002	8	36'-10"	1002				
SLAB LONGITUDINAL BOTTOM, AT RAIL		9a7	8	13'-0"	354	8	13'-0"	354	8	13'-0"	354	8	13'-0"	354				
SLAB LONGITUDINAL BOTTOM, AT RAIL		9a8	4	45'-2"	615	4	45'-2"	615	4	45'-2"	615	4	45'-2"	615				
SLAB LONGITUDINAL BOTTOM, AT RAIL		8a9	8	30'-3"	647	8	30'-3"	647	8	30'-3"	647	8	30'-3"	647				
SLAB LONGITUDINAL BOTTOM, AT RAIL		9a10	4	26'-4"	359	4	26'-4"	359	4	26'-4"	359	4	26'-4"	359				
SLAB LONGITUDINAL TOP		6b1	39	7'-6"	440	39	7'-6"	440	39	7'-6"	440	39	7'-6"	440				
SLAB LONGITUDINAL TOP		11b2	39	26'-3"	5440	39	26'-3"	5440	39	26'-3"	5440	39	26'-3"	5440				
SLAB LONGITUDINAL TOP		11b3	39	28'-0"	5802	39	28'-0"	5802	39	28'-0"	5802	39	28'-0"	5802				
SLAB LONGITUDINAL TOP		7b4	39	24'-2"	1927	39	24'-2"	1927	39	24'-2"	1927	39	24'-2"	1927				
SLAB LONGITUDINAL TOP		10b5	40	23'-6"	4045	40	23'-6"	4045	40	23'-6"	4045	40	23'-6"	4045				
SLAB LONGITUDINAL TOP		6b6	20	35'-6"	1067	20	35'-6"	1067	20	35'-6"	1067	20	35'-6"	1067				
SLAB LONGITUDINAL TOP, AT RAIL		6b8	8	30'-11"	372	8	30'-11"	372	8	30'-11"	372	8	30'-11"	372				
SLAB LONGITUDINAL TOP, AT RAIL		11b9	8	30'-3"	1286	8	30'-3"	1286	8	30'-3"	1286	8	30'-3"	1286				
SLAB LONGITUDINAL TOP, AT RAIL		6b10	4	24'-4"	147	4	24'-4"	147	4	24'-4"	147	4	24'-4"	147				
SLAB LONGITUDINAL TOP, AT RAIL		7b11	8	35'-11"	588	8	35'-11"	588	8	35'-11"	588	8	35'-11"	588				
SLAB LONGITUDINAL TOP, AT RAIL		11b12	8	21'-3"	904	8	21'-3"	904	8	21'-3"	904	8	21'-3"	904				
SLAB TRANSVERSE, BOTTOM		6c1	127	32'-10"	6264	127	34'-0"	6486	114	32'-10"	5622	100	32'-10"	4932				
SLAB TRANSVERSE ENDS, BOTTOM		6c2	-	-	-	-	-	-	30	VARIES	797	56	VARIES	1486				
SLAB TRANSVERSE, TOP		5d1	127	32'-10"	4350	127	34'-0"	4504	114	32'-10"	3904	100	32'-10"	3425				
SLAB TRANSVERSE ENDS, TOP		5d2	-	-	-	-	-	-	30	VARIES	553	56	VARIES	1032				
SLAB, TRANSVERSE AT ABUTMENT		8e1	18	32'-10"	1578	-	-	-	-	-	-	-	-	-				
SLAB, TRANSVERSE AT ABUTMENT		8e2	-	-	-	18	33'-11"	1631	18	37'-6"	1803	18	45'-4"	2179				
SLAB, HAIRPINS, AT ABUTMENT		6e3	72	5'-0"	541	72	5'-1"	550	72	5'-5"	586	72	6'-1"	658				
SLAB, DIAGONALS, AT ABUTMENT		6e4	72	5'-11"	640	72	5'-11"	640	72	5'-11"	640	7	5'-11"	640				
PIER CAP HOOPS		5h1	44	8'-1"	371	44	8'-1"	371	44	8'-1"	371	66	8'-1"	557				
PIER CAP ENDS		8h2	4	14'-5"	154	4	14'-5"	154	4	14'-5"	154	4	14'-5"	154				
PIER CAP, BOTTOM LONGITUDINAL		8h3	8	29'-10"	638	8	30'-11"	661	8	34'-5"	736	8	42'-2"	901				
PIER CAP, TOP LONGITUDINAL		8h4	4	32'-10"	351	4	34'-0"	364	4	37'-11"	405	4	46'-6"	497				
TOP OF SLAB, TRANSVERSE, AT RAIL		5j1	252	8'-6"	2235	252	8'-6"	2235	252	8'-6"	2235	250	8'-6"	2217				
WING, VERTICAL		5m1	40	4'-5"	185	40	4'-5"	185	40	4'-5"	185	40	4'-5"	185				
WING, HORIZONTAL BACK FACE		5n1	24	6'-8"	167	24	6'-8"	167	24	6'-8"	167	24	6'-8"	167				
WING, HORIZONTAL TRAFFIC FACE		5n3	24	6'-9"	169	24	6'-9"	169	24	6'-9"	169	24	6'-9"	169				
PAVING BLOCK LIFTING HOOPS		5z1	10	2'-10"	30	10	2'-10"	30	10	2'-10"	30	10	2'-10"	30				
SUB TOTAL - LBS.					64,579			65,053			65,263			66,135				
BARRIER RAIL - SEE LIST ON RAIL SHEET J30-41-06					8054			8054			8054			8054				
OPEN RAIL - SEE LIST ON RAIL SHEET J30-44-06					8573			8573			8573			8573				
TOTAL - LBS.			WITH MONOLITHIC PIER CAP		72,636			73,107			73,317			74,189				
			WITH BARRIER RAIL					73,626			73,836			74,708				
TOTAL - LBS.			WITH NON-MONOLITHIC PIER CAP		71,119			71,557			71,651			72,080				
			WITH BARRIER RAIL					72,076			72,170			72,599				
SAME AS ABOVE EXCEPT ALL "h" BARS DELETED			WITH OPEN RAIL		71,638													

ESTIMATED QUANTITIES FOR SUPERSTRUCTURE - 130' BRIDGE

ITEM	SKEW	WITH MONOLITHIC PIER CAP				WITH NON-MONOLITHIC PIER CAP			
		0°	15°	30°	45°	0°	15°	30°	45°
WITH *STRUCTURAL CONCRETE (BRIDGE)	C.Y.	308.1	308.9	311.5	317.0	303.5	304.1	306.2	310.7
BARRIER RAIL REINFORCING STEEL	LBS.	72,636	73,107	73,317	74,189	71,119	71,557	71,651	72,080
CONCRETE BARRIER OR OPEN RAIL	LIN. FT.	282.0	282.2	282.9	284.5	282.0	282.2	282.9	284.5
WITH *STRUCTURAL CONCRETE (BRIDGE)	C.Y.	307.9	308.6	311.3	316.8	303.3	303.9	306.0	310.4
OPEN RAIL REINFORCING STEEL	LBS.	73,152	73,626	73,836	74,708	71,638	72,076	72,170	72,599

* INCLUDES 4 WINGS @ 0.68 C.Y. EACH AND 2 TEMPORARY PAVING BLOCKS; EXCLUDES RAIL CONCRETE.

BENT BAR DETAILS

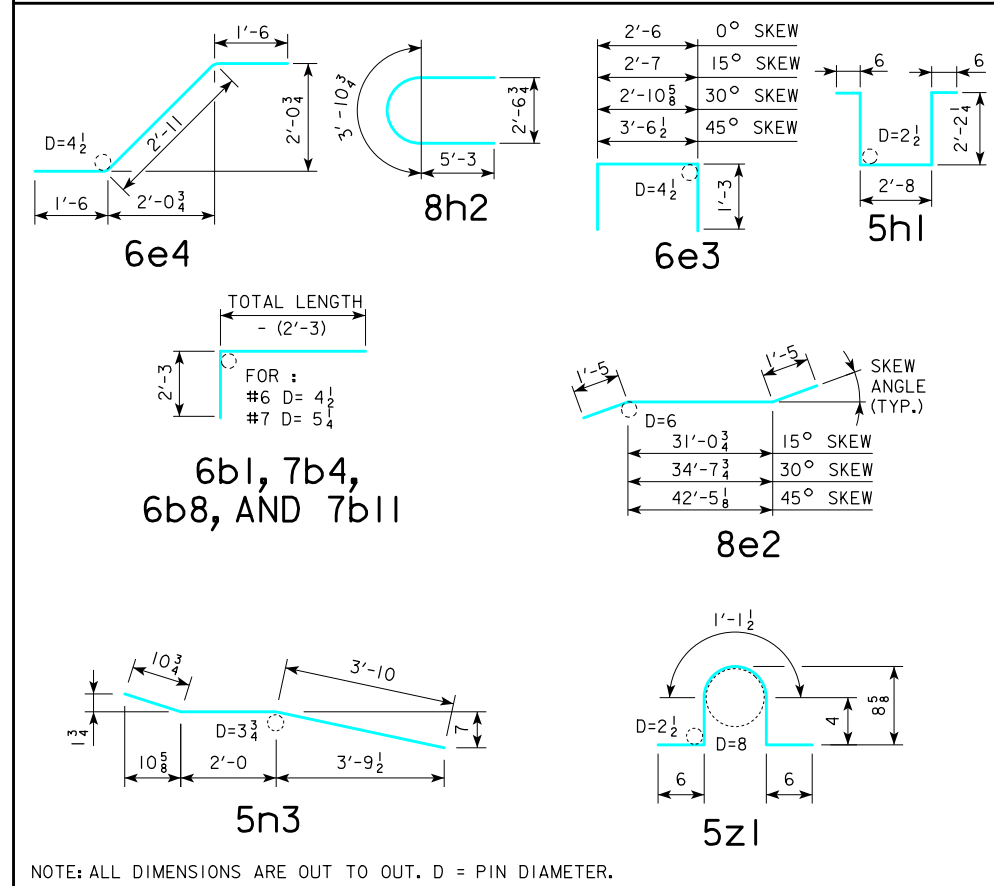

IOWA DOT Highway Division

STANDARD DESIGN - 30' ROADWAY, 3 SPAN BRIDGES

CONTINUOUS CONCRETE SLAB BRIDGES

NOVEMBER, 2006

09-2020
LATEST REVISION DATE

APPROVED BY BRIDGE ENGINEER

SUPERSTRUCTURE DETAILS
130'-0 BRIDGE

NON-EPOXY COATED REINFORCING

J30-15B-06

REVISED 07-2009; OPEN RAIL REINF. QTY'S. CHANGED WHICH CHANGED TOTAL REINF. QTY'S.
REVISED 09-2020; UPDATED BRIDGE ENGINEER SIGNATURE. CHANGED PAVING BLOCK LIFTING HOOP BAR MARK, (WAS 5x1).

BILL OF REINFORCING STEEL FOR SUPERSTRUCTURE - 130' BRIDGE

LOCATION	SKEW	SHAPE	0°				15°				30°				45°			
			BAR NO.	LENGTH	WEIGHT		BAR NO.	LENGTH	WEIGHT		BAR NO.	LENGTH	WEIGHT		BAR NO.	LENGTH	WEIGHT	
SLAB LONGITUDINAL BOTTOM		9a1	39	28'-9"	3813	39	28'-9"	3813	39	28'-9"	3813	39	28'-9"	3813				
SLAB LONGITUDINAL BOTTOM, AT RAIL		9a2	39	44'-6"	5901	39	44'-6"	5901	39	44'-6"	5901	39	44'-6"	5901				
SLAB LONGITUDINAL BOTTOM, AT RAIL		9a3	39	41'-3"	5470	39	41'-3"	5470	39	41'-3"	5470	39	41'-3"	5470				
SLAB LONGITUDINAL BOTTOM, AT RAIL		9a4	40	32'-9"	4454	40	32'-9"	4454	40	32'-9"	4454	40	32'-9"	4454				
SLAB LONGITUDINAL BOTTOM, AT RAIL		10a5	20	41'-0"	3529	20	41'-0"	3529	20	41'-0"	3529	20	41'-0"	3529				
SLAB LONGITUDINAL BOTTOM, AT RAIL		9a6	8	38'-7"	1050	8	38'-7"	1050	8	38'-7"	1050	8	38'-7"	1050				
SLAB LONGITUDINAL BOTTOM, AT RAIL		9a7	8	13'-0"	354	8	13'-0"	354	8	13'-0"	354	8	13'-0"	354				
SLAB LONGITUDINAL BOTTOM, AT RAIL		9a8	4	48'-8"	662	4	48'-8"	662	4	48'-8"	662	4	48'-8"	662				
SLAB LONGITUDINAL BOTTOM, AT RAIL		8a9	8	31'-3"	668	8	31'-3"	668	8	31'-3"	668	8	31'-3"	668				
SLAB LONGITUDINAL BOTTOM, AT RAIL		9a10	4	29'-0"	395	4	29'-0"	395	4	29'-0"	395	4	29'-0"	395				
SLAB LONGITUDINAL TOP		6b1	39	7'-9"	454	39	7'-9"	454	39	7'-9"	454	39	7'-9"	454				
SLAB LONGITUDINAL TOP		11b2	39	28'-9"	5958	39	28'-9"	5958	39	28'-9"	5958	39	28'-9"	5958				
SLAB LONGITUDINAL TOP		11b3	39	30'-6"	6320	39	30'-6"	6320	39	30'-6"	6320	39	30'-6"	6320				
SLAB LONGITUDINAL TOP		7b4	39	23'-9"	1894	39	23'-9"	1894	39	23'-9"	1894	39	23'-9"	1894				
SLAB LONGITUDINAL TOP		10b5	40	25'-6"	4390	40	25'-6"	4390	40	25'-6"	4390	40	25'-6"	4390				
SLAB LONGITUDINAL TOP		6b6	20	34'-4"	1032	20	34'-4"	1032	20	34'-4"	1032	20	34'-4"	1032				
SLAB LONGITUDINAL TOP, AT RAIL		6b8	8	30'-3"	364	8	30'-3"	364	8	30'-3"	364	8	30'-3"	364				
SLAB LONGITUDINAL TOP, AT RAIL		11b9	8	32'-9"	1393	8	32'-9"	1393	8	32'-9"	1393	8	32'-9"	1393				
SLAB LONGITUDINAL TOP, AT RAIL		6b10	4	23'-0"	139	4	23'-0"	139	4	23'-0"	139	4	23'-0"	139				
SLAB LONGITUDINAL TOP, AT RAIL		7b11	8	35'-6"	581	8	35'-6"	581	8	35'-6"	581	8	35'-6"	581				
SLAB LONGITUDINAL TOP, AT RAIL		11b12	8	23'-9"	1010	8	23'-9"	1010	8	23'-9"	1010	8	23'-9"	1010				
SLAB TRANSVERSE, BOTTOM		6c1	127	32'-10"	6264	127	34'-0"	6486	114	32'-10"	5622	100	32'-10"	4932				
SLAB TRANSVERSE ENDS, BOTTOM		6c2	-	-	-	-	-	-	30	VARIES	797	56	VARIES	1486				
SLAB TRANSVERSE, TOP		5d1	127	32'-10"	4350	127	34'-0"	4504	114	32'-10"	3904	100	32'-10"	3425				
SLAB TRANSVERSE ENDS, TOP		5d2	-	-	-	-	-	-	30	VARIES	553	56	VARIES	1032				
SLAB, TRANSVERSE AT ABUTMENT		8e1	18	32'-10"	1578	-	-	-	-	-	-	-	-	-				
SLAB, TRANSVERSE AT ABUTMENT		8e2	-	-	-	18	33'-11"	1631	18	37'-6"	1803	18	45'-4"	2179				
SLAB, HAIRPINS, AT ABUTMENT		6e3	72	5'-0"	541	72	5'-1"	550	72	5'-5"	586	72	6'-1"	658				
SLAB, DIAGONALS, AT ABUTMENT		6e4	72	5'-11"	640	72	5'-11"	640	72	5'-11"	640	72	5'-11"	640				
PIER CAP HOOPS		5h1	44	8'-1"	371	44	8'-1"	371	44	8'-1"	371	66	8'-1"	557				
PIER CAP ENDS		8h2	4	14'-5"	154	4	14'-5"	154	4	14'-5"	154	4	14'-5"	154				
PIER CAP, BOTTOM LONGITUDINAL		8h3	8	29'-10"	638	8	30'-11"	661	8	34'-5"	736	8	42'-2"	901				
PIER CAP, TOP LONGITUDINAL		8h4	4	32'-10"	351	4	34'-0"	364	4	37'-11"	405	4	46'-6"	497				
TOP OF SLAB, TRANSVERSE, AT RAIL		5j1	252	8'-6"	2235	252	8'-6"	2235	252	8'-6"	2235	250	8'-6"	2217				
WING, VERTICAL		5m1	40	4'-5"	185	40	4'-5"	185	40	4'-5"	185	40	4'-5"	185				
WING, HORIZONTAL BACK FACE		5n1	24	6'-8"	167	24	6'-8"	167	24	6'-8"	167	24	6'-8"	167				
WING, HORIZONTAL TRAFFIC FACE		5n3	24	6'-9"	169	24	6'-9"	169	24	6'-9"	169	24	6'-9"	169				
** PAVING BLOCK LIFTING HOOPS		5z1	10	2'-10"	30	10	2'-10"	30	10	2'-10"	30	10	2'-10"	30				
SUB TOTAL - LBS.					67,504			67,978			68,188			69,060				
BARRIER RAIL - SEE LIST ON RAIL SHEET J30-41-06					8054			8054			8054			8054				
OPEN RAIL - SEE LIST ON RAIL SHEET J30-44-06					8573			8573			8573			8573				
TOTAL - LBS.			WITH MONOLITHIC PIER CAP	WITH BARRIER RAIL	75,558			76,032			76,242			77,114				
				WITH OPEN RAIL	76,077			76,551			76,761			77,633				
TOTAL - LBS.			WITH NON-MONOLITHIC PIER CAP	WITH BARRIER RAIL	74,044			74,482			74,576			75,005				
				WITH OPEN RAIL	74,563			75,001			75,095			75,524				
SAME AS ABOVE EXCEPT ALL "h" BARS DELETED																		
** BARS MAY BE NON-COATED AT CONTRACTOR'S OPTION.																		

ESTIMATED QUANTITIES FOR SUPERSTRUCTURE - 130' BRIDGE

ITEM	SKEW	WITH MONOLITHIC PIER CAP				WITH NON-MONOLITHIC PIER CAP			
		0°	15°	30°	45°	0°	15°	30°	45°
WITH *STRUCTURAL CONCRETE (BRIDGE) C.Y.		308.1	308.9	311.5	317.0	303.5	304.1	306.2	310.7
BARRIER RAIL REINFORCING STEEL EPOXY COATED LBS.		75,558	76,032	76,242	77,114	74,044	74,482	74,576	75,005
CONCRETE BARRIER OR OPEN RAIL LIN. FT.		282.0	282.2	282.9	284.5	282.0	282.2	282.9	284.5
WITH *STRUCTURAL CONCRETE (BRIDGE) C.Y.		307.9	308.6	311.3	316.8	303.3	303.9	306.0	310.5
OPEN RAIL REINFORCING STEEL EPOXY COATED LBS.		76,077	76,551	76,761	77,633	74,563	75,001	75,095	75,524

* INCLUDES 4 WINGS @ 0.68 C.Y. EACH AND 2 TEMPORARY PAVING BLOCKS; EXCLUDES RAIL CONCRETE.

BENT BAR DETAILS

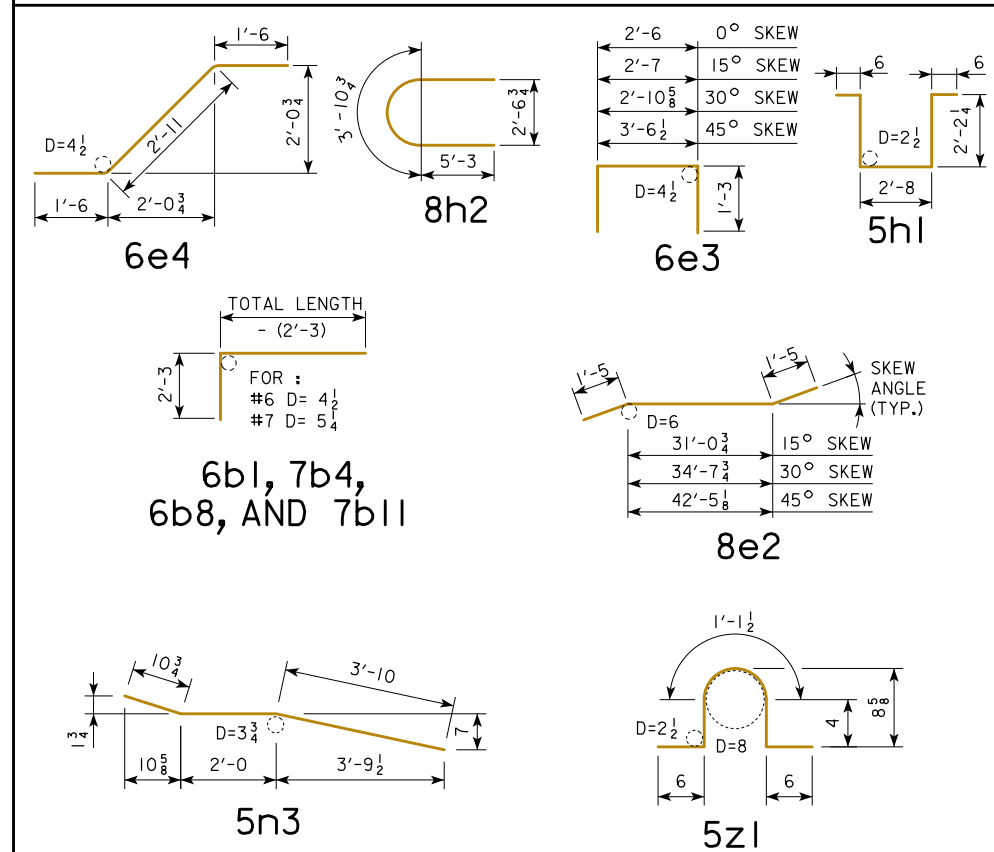

09-2020 LATEST REVISION DATE		APPROVED BY BRIDGE ENGINEER	IOWA DOT Highway Division	
			STANDARD DESIGN - 30' ROADWAY, 3 SPAN BRIDGES	
			CONTINUOUS CONCRETE SLAB BRIDGES	
			NOVEMBER, 2006	
			SUPERSTRUCTURE DETAILS	
			130'-0 BRIDGE	
			J30-15E-06	
			EPOXY COATED REINFORCING	

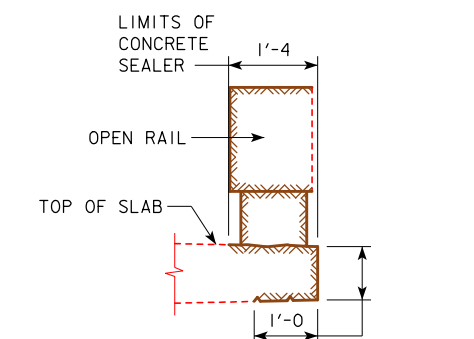
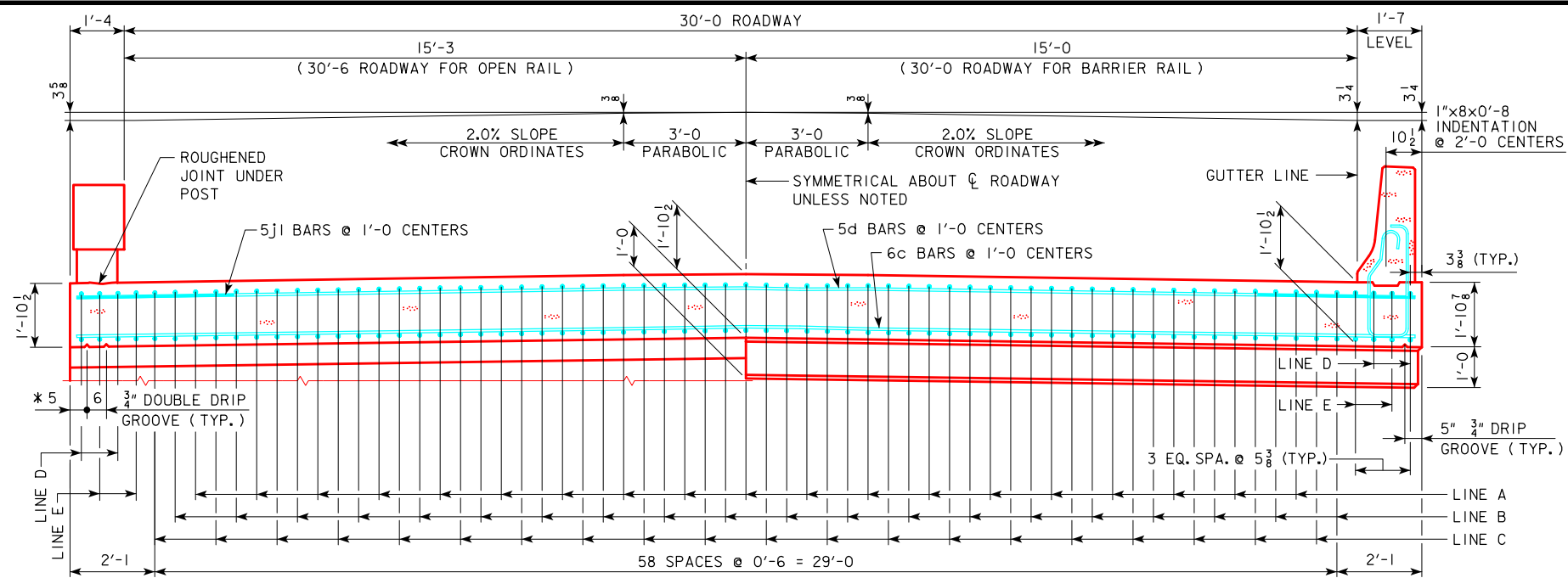

CONCRETE SEALER LIMITS FOR OPEN RAILS

CONCRETE SEALER SHALL BE APPLIED TO BOTH SIDES OF BRIDGE SLAB ON THE TOP, EDGE OF SLAB AND UNDER THE SLAB. THE CONCRETE SEALER SHALL ALSO BE APPLIED TO THE OPEN RAIL ON THE TOP, TRAFFIC FACE SIDE, BOTTOM OF RAIL, AND ON ALL SIDES OF THE OPEN RAIL POSTS.

THE CONCRETE SEALER LIMITS ARE SHOWN IN THE DETAIL AND SHALL APPLY TO THE FULL LENGTH OF BRIDGE. CONCRETE SEALER SHALL BE APPLIED IN ACCORDANCE WITH ARTICLE 2403.03, P, 3 OF THE STANDARD SPECIFICATIONS.

HALF SECTION NEAR ABUTMENT

HALF SECTION NEAR PIER

* NOTE: DOUBLE DRIP GROOVES FOR OPEN RAIL OPTION ONLY.

SLAB CROSS-SECTIONAL AREA FOR OPEN RAIL = 62.19 SQ. FT.

NOTE: TOP LONGITUDINAL REINFORCING STEEL IS TO BE PARALLEL TO AND 2 1/2" CLEAR BELOW TOP OF SLAB. BOTTOM LONGITUDINAL REINFORCING STEEL IS TO BE PARALLEL TO AND 1 1/2" CLEAR ABOVE BOTTOM OF SLAB. REINFORCING STEEL IS TO BE SECURELY WIRED IN PLACE AND ADEQUATELY SUPPORTED ON BAR CHAIRS BEFORE CONCRETE IS POURED. I.M. 451.01 REQUIREMENTS SHALL APPLY FOR BAR CHAIRS.

SLAB CROSS-SECTIONAL AREA FOR BARRIER RAIL = 62.24 SQ. FT.

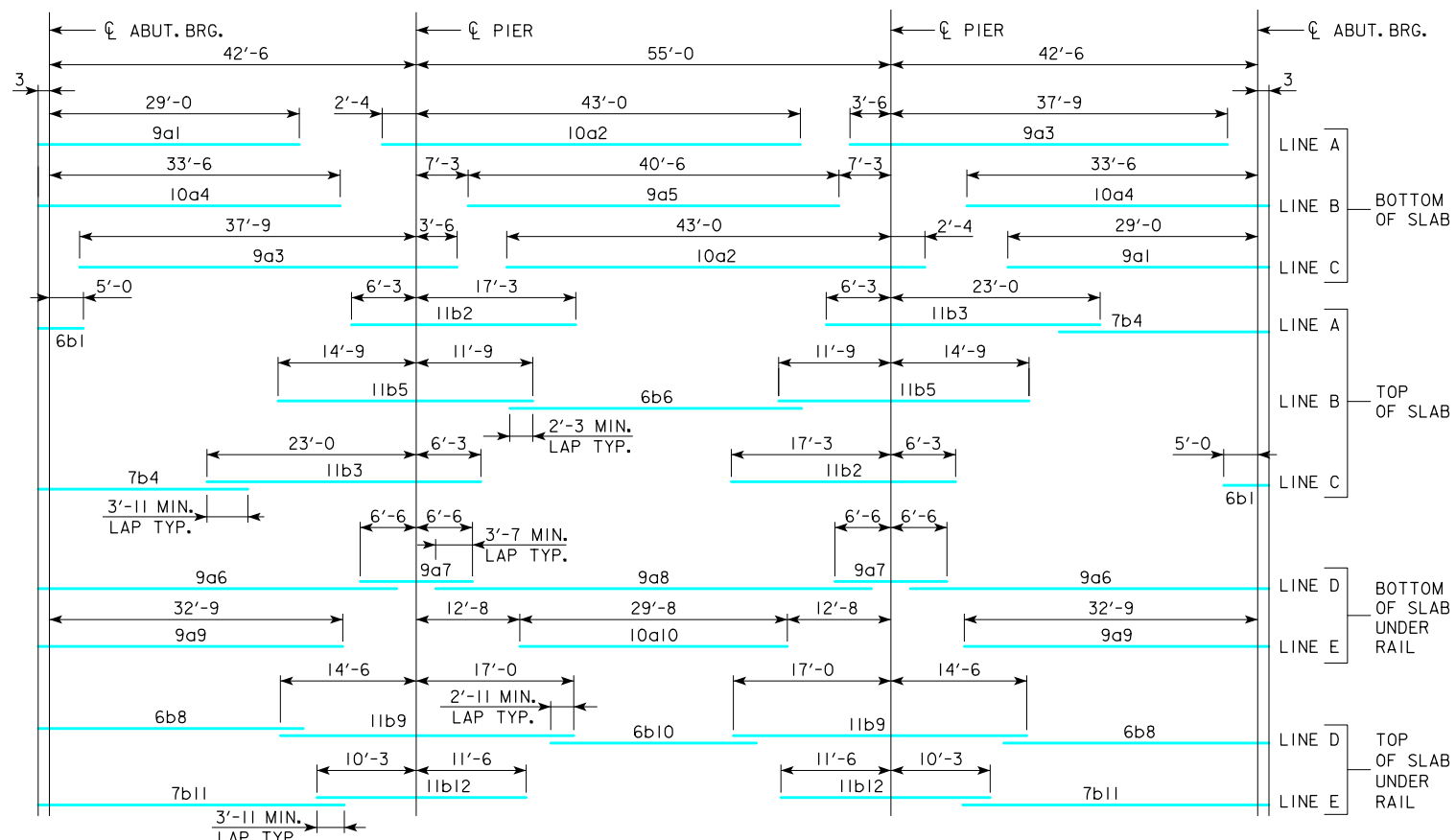

PLACEMENT FOR LONGITUDINAL REINFORCEMENT

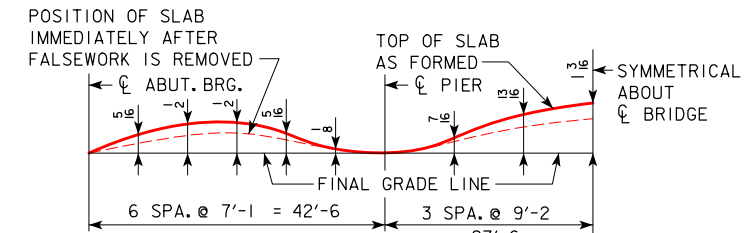

FORM CAMBER DIAGRAM

THIS DIAGRAM SHOWS THE FORM CAMBER REQUIRED TO COMPENSATE FOR THE ANTICIPATED ULTIMATE DEAD LOAD DEFLECTION. THE ABOVE DIMENSIONS DO NOT INCLUDE ANY ALLOWANCE FOR FORM DEFLECTION OR FALSEWORK SETTLEMENT.

REVISED 07-2016; DATE ON SHEET CHANGED TO CORRECT CLERICAL ERROR.
 REVISED 09-2020; UPDATED BRIDGE ENGINEER SIGNATURE.

09-2020 LATEST REVISION DATE	APPROVED BY BRIDGE ENGINEER		
		STANDARD DESIGN - 30' ROADWAY, 3 SPAN BRIDGES CONTINUOUS CONCRETE SLAB BRIDGES NOVEMBER, 2006	
		SUPERSTRUCTURE DETAILS 140'-0 BRIDGE	J30-16B-06

NON-EPOXY COATED REINFORCING

REVISED 07-2009: OPEN RAIL REINF. QTY'S. CHANGED WHICH CHANGED TOTAL REINF. QTY'S.
REVISED 09-2020: UPDATED BRIDGE ENGINEER SIGNATURE. CHANGED PAVING BLOCK LIFTING HOOP BAR MARK, (WAS 5x1).

BILL OF REINFORCING STEEL FOR SUPERSTRUCTURE - 140' BRIDGE

LOCATION	SKEW	SHAPE	BAR	0°		15°		30°		45°				
				NO.	LENGTH	WEIGHT	NO.	LENGTH	WEIGHT	NO.	LENGTH	WEIGHT	NO.	LENGTH
SLAB LONGITUDINAL BOTTOM		9a1	39	29'-3"	3879	39	29'-3"	3879	39	29'-3"	3879	39	29'-3"	3879
SLAB LONGITUDINAL BOTTOM		10a2	39	45'-4"	7608	39	45'-4"	7608	39	45'-4"	7608	39	45'-4"	7608
SLAB LONGITUDINAL BOTTOM		9a3	39	41'-3"	5470	39	41'-3"	5470	39	41'-3"	5470	39	41'-3"	5470
SLAB LONGITUDINAL BOTTOM		10a4	40	33'-9"	5810	40	33'-9"	5810	40	33'-9"	5810	40	33'-9"	5810
SLAB LONGITUDINAL BOTTOM		9a5	20	40'-6"	2754	20	40'-6"	2754	20	40'-6"	2754	20	40'-6"	2754
SLAB LONGITUDINAL BOTTOM, AT RAIL		9a6	8	39'-10"	1084	8	39'-10"	1084	8	39'-10"	1084	8	39'-10"	1084
SLAB LONGITUDINAL BOTTOM, AT RAIL		9a7	8	13'-0"	354	8	13'-0"	354	8	13'-0"	354	8	13'-0"	354
SLAB LONGITUDINAL BOTTOM, AT RAIL		9a8	4	49'-2"	669	4	49'-2"	669	4	49'-2"	669	4	49'-2"	669
SLAB LONGITUDINAL BOTTOM, AT RAIL		9a9	8	33'-0"	898	8	33'-0"	898	8	33'-0"	898	8	33'-0"	898
SLAB LONGITUDINAL BOTTOM, AT RAIL		10a10	4	29'-8"	511	4	29'-8"	511	4	29'-8"	511	4	29'-8"	511
SLAB LONGITUDINAL TOP		6b1	39	7'-6"	440	39	7'-6"	440	39	7'-6"	440	39	7'-6"	440
SLAB LONGITUDINAL TOP		11b2	39	23'-6"	4870	39	23'-6"	4870	39	23'-6"	4870	39	23'-6"	4870
SLAB LONGITUDINAL TOP		11b3	39	29'-3"	6061	39	29'-3"	6061	39	29'-3"	6061	39	29'-3"	6061
SLAB LONGITUDINAL TOP		7b4	39	25'-11"	2066	39	25'-11"	2066	39	25'-11"	2066	39	25'-11"	2066
SLAB LONGITUDINAL TOP		11b5	40	26'-6"	5632	40	26'-6"	5632	40	26'-6"	5632	40	26'-6"	5632
SLAB LONGITUDINAL TOP		6b6	20	36'-0"	1082	20	36'-0"	1082	20	36'-0"	1082	20	36'-0"	1082
SLAB LONGITUDINAL TOP, AT RAIL		6b8	8	33'-5"	402	8	33'-5"	402	8	33'-5"	402	8	33'-5"	402
SLAB LONGITUDINAL TOP, AT RAIL		11b9	8	31'-6"	1339	8	31'-6"	1339	8	31'-6"	1339	8	31'-6"	1339
SLAB LONGITUDINAL TOP, AT RAIL		6b10	4	26'-10"	162	4	26'-10"	162	4	26'-10"	162	4	26'-10"	162
SLAB LONGITUDINAL TOP, AT RAIL		7b11	8	38'-8"	633	8	38'-8"	633	8	38'-8"	633	8	38'-8"	633
SLAB LONGITUDINAL TOP, AT RAIL		11b12	8	21'-9"	925	8	21'-9"	925	8	21'-9"	925	8	21'-9"	925
SLAB TRANSVERSE, BOTTOM		6c1	137	32'-10"	6757	137	34'-0"	6997	124	32'-10"	6116	110	32'-10"	5425
SLAB TRANSVERSE ENDS, BOTTOM		6c2	-	-	-	-	-	-	30	VARIES	797	56	VARIES	1486
SLAB TRANSVERSE, TOP		5d1	137	32'-10"	4692	137	34'-0"	4859	124	32'-10"	4247	110	32'-10"	3767
SLAB TRANSVERSE ENDS, TOP		5d2	-	-	-	-	-	-	30	VARIES	553	56	VARIES	1032
SLAB, TRANSVERSE AT ABUTMENT		8e1	18	32'-10"	1578	-	-	-	-	-	-	-	-	-
SLAB, TRANSVERSE AT ABUTMENT		8e2	-	-	-	18	33'-11"	1631	18	37'-6"	1803	18	45'-4"	2179
SLAB, HAIRPINS, AT ABUTMENT		6e3	72	5'-0"	541	72	5'-1"	550	72	5'-5"	586	72	6'-1"	658
SLAB, DIAGONALS, AT ABUTMENT		6e4	72	5'-11"	640	72	5'-11"	640	72	5'-11"	640	72	5'-11"	640
PIER CAP HOOPS		5h1	44	8'-3"	379	44	8'-3"	379	44	8'-3"	379	66	8'-3"	568
PIER CAP ENDS		8h2	4	14'-5"	154	4	14'-5"	154	4	14'-5"	154	4	14'-5"	154
PIER CAP, BOTTOM LONGITUDINAL		8h3	8	29'-10"	638	8	30'-11"	661	8	34'-5"	736	8	42'-2"	901
PIER CAP, TOP LONGITUDINAL		8h4	4	32'-10"	351	4	34'-0"	364	4	37'-11"	405	4	46'-6"	497
TOP OF SLAB, TRANSVERSE, AT RAIL		5j1	272	8'-6"	2412	272	8'-6"	2412	272	8'-6"	2412	270	8'-6"	2394
WING, VERTICAL		5m1	40	4'-5"	185	40	4'-5"	185	40	4'-5"	185	40	4'-5"	185
WING, HORIZONTAL BACK FACE		5n1	24	6'-8"	167	24	6'-8"	167	24	6'-8"	167	24	6'-8"	167
WING, HORIZONTAL TRAFFIC FACE		5n3	24	6'-9"	169	24	6'-9"	169	24	6'-9"	169	24	6'-9"	169
PAVING BLOCK LIFTING HOOPS		5z1	10	2'-10"	30	10	2'-10"	30	10	2'-10"	30	10	2'-10"	30
SUB TOTAL - LBS.					71,342		71,847		72,028		72,901			
BARRIER RAIL - SEE LIST ON RAIL SHEET J30-41-06					8602		8602		8602		8602			
OPEN RAIL - SEE LIST ON RAIL SHEET J30-44-06					9057		9057		9057		9057			
TOTAL - LBS.					79,944		80,449		80,630		81,503			
WITH MONOLITHIC PIER CAP					80,399		80,904		81,085		81,958			
TOTAL - LBS.					78,422		78,891		78,956		79,383			
SAME AS ABOVE EXCEPT ALL "h" BARS DELETED					78,877		79,346		79,411		79,838			

ESTIMATED QUANTITIES FOR SUPERSTRUCTURE - 140' BRIDGE

ITEM	SKEW	WITH MONOLITHIC PIER CAP				WITH NON-MONOLITHIC PIER CAP			
		0°	15°	30°	45°	0°	15°	30°	45°
WITH *STRUCTURAL CONCRETE (BRIDGE)	C.Y.	347.4	348.1	350.7	356.2	342.8	343.4	345.5	349.8
BARRIER RAIL REINFORCING STEEL	LBS.	79,944	80,449	80,630	81,503	78,422	78,891	78,956	79,383
CONCRETE BARRIER OR OPEN RAIL	LIN. FT.	302.0	302.2	302.9	304.5	302.0	302.2	302.9	304.5
WITH *STRUCTURAL CONCRETE (BRIDGE)	C.Y.	347.2	347.9	350.5	355.9	342.6	343.1	345.2	349.5
OPEN RAIL REINFORCING STEEL	LBS.	80,399	80,904	81,085	81,958	78,877	79,346	79,411	79,838

* INCLUDES 4 WINGS @ 0.68 C.Y. EACH AND 2 TEMPORARY PAVING BLOCKS; EXCLUDES RAIL CONCRETE.

BENT BAR DETAILS

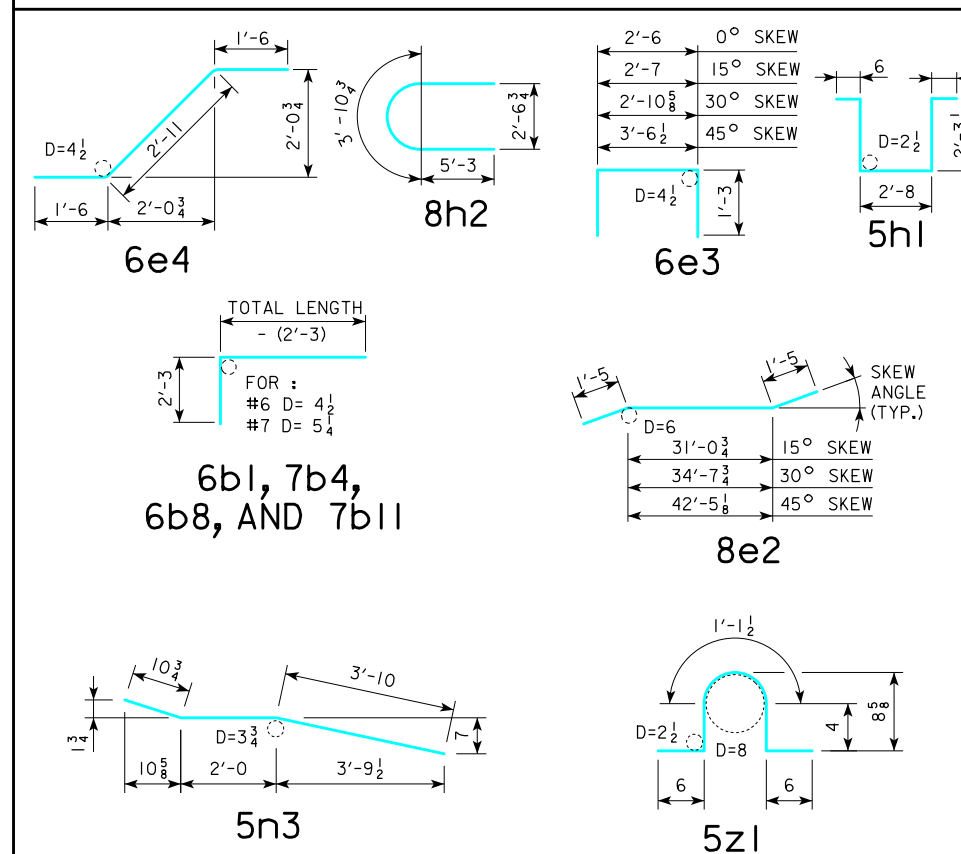

NOTE: ALL DIMENSIONS ARE OUT TO OUT. D = PIN DIAMETER.

09-2020 LATEST REVISION DATE	 APPROVED BY BRIDGE ENGINEER	
		STANDARD DESIGN - 30' ROADWAY, 3 SPAN BRIDGES CONTINUOUS CONCRETE SLAB BRIDGES NOVEMBER, 2006
		SUPERSTRUCTURE DETAILS 140'-0 BRIDGE
		J30-17B-06
NON-EPOXY COATED REINFORCING		

REVISED 07-2009: OPEN RAIL REINF. QTY'S. CHANGED WHICH CHANGED TOTAL REINF. QTY'S.
REVISED 09-2020: UPDATED BRIDGE ENGINEER SIGNATURE. CHANGED PAVING BLOCK LIFTING HOOP BAR MARK, (WAS 5x1).

BILL OF REINFORCING STEEL FOR SUPERSTRUCTURE - 140' BRIDGE

LOCATION	SKEW	SHAPE	0°				15°				30°				45°						
			BAR	NO.	LENGTH	WEIGHT	BAR	NO.	LENGTH	WEIGHT	BAR	NO.	LENGTH	WEIGHT	BAR	NO.	LENGTH	WEIGHT			
SLAB LONGITUDINAL BOTTOM			9a1	39	30'-6"	4045	39	30'-6"	4045	39	30'-6"	4045	39	30'-6"	4045						
SLAB LONGITUDINAL BOTTOM			10a2	39	48'-6"	8140	39	48'-6"	8140	39	48'-6"	8140	39	48'-6"	8140						
SLAB LONGITUDINAL BOTTOM			9a3	39	43'-9"	5802	39	43'-9"	5802	39	43'-9"	5802	39	43'-9"	5802						
SLAB LONGITUDINAL BOTTOM			10a4	40	35'-3"	6068	40	35'-3"	6068	40	35'-3"	6068	40	35'-3"	6068						
SLAB LONGITUDINAL BOTTOM			9a5	20	43'-0"	2924	20	43'-0"	2924	20	43'-0"	2924	20	43'-0"	2924						
SLAB LONGITUDINAL BOTTOM, AT RAIL			9a6	8	41'-7"	1132	8	41'-7"	1132	8	41'-7"	1132	8	41'-7"	1132						
SLAB LONGITUDINAL BOTTOM, AT RAIL			9a7	8	13'-0"	354	8	13'-0"	354	8	13'-0"	354	8	13'-0"	354						
SLAB LONGITUDINAL BOTTOM, AT RAIL			9a8	4	52'-8"	717	4	52'-8"	717	4	52'-8"	717	4	52'-8"	717						
SLAB LONGITUDINAL BOTTOM, AT RAIL			9a9	8	34'-3"	932	8	34'-3"	932	8	34'-3"	932	8	34'-3"	932						
SLAB LONGITUDINAL BOTTOM, AT RAIL			10a10	4	33'-0"	568	4	33'-0"	568	4	33'-0"	568	4	33'-0"	568						
SLAB LONGITUDINAL TOP			6b1	39	7'-9"	454	39	7'-9"	454	39	7'-9"	454	39	7'-9"	454						
SLAB LONGITUDINAL TOP			11b2	39	26'-0"	5388	39	26'-0"	5388	39	26'-0"	5388	39	26'-0"	5388						
SLAB LONGITUDINAL TOP			11b3	39	31'-9"	6579	39	31'-9"	6579	39	31'-9"	6579	39	31'-9"	6579						
SLAB LONGITUDINAL TOP			7b4	39	25'-6"	2033	39	25'-6"	2033	39	25'-6"	2033	39	25'-6"	2033						
SLAB LONGITUDINAL TOP			11b5	40	29'-0"	6164	40	29'-0"	6164	40	29'-0"	6164	40	29'-0"	6164						
SLAB LONGITUDINAL TOP			6b6	20	34'-4"	1032	20	34'-4"	1032	20	34'-4"	1032	20	34'-4"	1032						
SLAB LONGITUDINAL TOP, AT RAIL			6b8	8	32'-9"	394	8	32'-9"	394	8	32'-9"	394	8	32'-9"	394						
SLAB LONGITUDINAL TOP, AT RAIL			11b9	8	34'-0"	1446	8	34'-0"	1446	8	34'-0"	1446	8	34'-0"	1446						
SLAB LONGITUDINAL TOP, AT RAIL			6b10	4	25'-6"	154	4	25'-6"	154	4	25'-6"	154	4	25'-6"	154						
SLAB LONGITUDINAL TOP, AT RAIL			7b11	8	38'-3"	626	8	38'-3"	626	8	38'-3"	626	8	38'-3"	626						
SLAB LONGITUDINAL TOP, AT RAIL			11b12	8	24'-3"	1031	8	24'-3"	1031	8	24'-3"	1031	8	24'-3"	1031						
SLAB TRANSVERSE, BOTTOM			6c1	137	32'-10"	6757	137	34'-0"	6997	124	32'-10"	6116	110	32'-10"	5425						
SLAB TRANSVERSE ENDS, BOTTOM			6c2	-	-	-	-	-	-	30	VARIES	797	56	VARIES	1486						
SLAB TRANSVERSE, TOP			5d1	137	32'-10"	4692	137	34'-0"	4859	124	32'-10"	4247	110	32'-10"	3767						
SLAB TRANSVERSE ENDS, TOP			5d2	-	-	-	-	-	-	30	VARIES	553	56	VARIES	1032						
SLAB, TRANSVERSE AT ABUTMENT			8e1	18	32'-10"	1578	-	-	-	-	-	-	-	-	-						
SLAB, TRANSVERSE AT ABUTMENT			8e2	-	-	-	18	33'-11"	1631	18	37'-6"	1803	18	45'-4"	2179						
SLAB, HAIRPINS, AT ABUTMENT			6e3	72	5'-0"	541	72	5'-1"	550	72	5'-5"	586	72	6'-1"	658						
SLAB, DIAGONALS, AT ABUTMENT			6e4	72	5'-11"	640	72	5'-11"	640	72	5'-11"	640	72	5'-11"	640						
PIER CAP HOOPS			5h1	44	8'-3"	379	44	8'-3"	379	44	8'-3"	379	66	8'-3"	568						
PIER CAP ENDS			8h2	4	14'-5"	154	4	14'-5"	154	4	14'-5"	154	4	14'-5"	154						
PIER CAP, BOTTOM LONGITUDINAL			8h3	8	29'-10"	638	8	30'-11"	661	8	34'-5"	736	8	42'-2"	901						
PIER CAP, TOP LONGITUDINAL			8h4	4	32'-10"	351	4	34'-0"	364	4	37'-11"	405	4	46'-6"	497						
TOP OF SLAB, TRANSVERSE, AT RAIL			5j1	272	8'-6"	2412	272	8'-6"	2412	272	8'-6"	2412	270	8'-6"	2394						
WING, VERTICAL			5m1	40	4'-5"	185	40	4'-5"	185	40	4'-5"	185	40	4'-5"	185						
WING, HORIZONTAL BACK FACE			5n1	24	6'-8"	167	24	6'-8"	167	24	6'-8"	167	24	6'-8"	167						
WING, HORIZONTAL TRAFFIC FACE			5n3	24	6'-9"	169	24	6'-9"	169	24	6'-9"	169	24	6'-9"	169						
** PAVING BLOCK LIFTING HOOPS			5z1	10	2'-10"	30	10	2'-10"	30	10	2'-10"	30	10	2'-10"	30						
SUB TOTAL - LBS.						74,676							75,181							75,362	76,235
BARRIER RAIL - SEE LIST ON RAIL SHEET J30-41-06						8602							8602							8602	8602
OPEN RAIL - SEE LIST ON RAIL SHEET J30-44-06						9057							9057							9057	9057
TOTAL - LBS.							WITH MONOLITHIC PIER CAP						83,278							83,964	84,837
							WITH BARRIER RAIL						83,783							84,419	85,292
							WITH OPEN RAIL						83,733							84,238	85,292
TOTAL - LBS.							WITH NON-MONOLITHIC PIER CAP						81,756							82,290	82,717
							WITH BARRIER RAIL						82,225							82,745	83,172
							WITH OPEN RAIL						82,211							82,745	83,172
SAME AS ABOVE EXCEPT ALL "h" BARS DELETED						82,211							82,680							82,745	83,172

** BARS MAY BE NON-COATED AT CONTRACTOR'S OPTION.

ESTIMATED QUANTITIES FOR SUPERSTRUCTURE - 140' BRIDGE

ITEM	SKEW	WITH MONOLITHIC PIER CAP				WITH NON-MONOLITHIC PIER CAP			
		0°	15°	30°	45°	0°	15°	30°	45°
WITH *STRUCTURAL CONCRETE (BRIDGE) C.Y.		347.4	348.1	350.7	356.2	342.8	343.4	345.5	349.8
BARRIER RAIL REINFORCING STEEL EPOXY COATED LBS.		83,278	83,783	83,964	84,837	81,756	82,225	82,290	82,717
CONCRETE BARRIER OR OPEN RAIL LIN. FT.		302.0	302.2	302.9	304.5	302.0	302.2	302.9	304.5
WITH *STRUCTURAL CONCRETE (BRIDGE) C.Y.		347.2	347.9	350.5	355.9	342.6	343.1	345.2	349.5
OPEN RAIL REINFORCING STEEL EPOXY COATED LBS.		83,733	84,238	84,419	85,292	82,211	82,680	82,745	83,172

* INCLUDES 4 WINGS @ 0.68 C.Y. EACH AND 2 TEMPORARY PAVING BLOCKS; EXCLUDES RAIL CONCRETE.

BENT BAR DETAILS

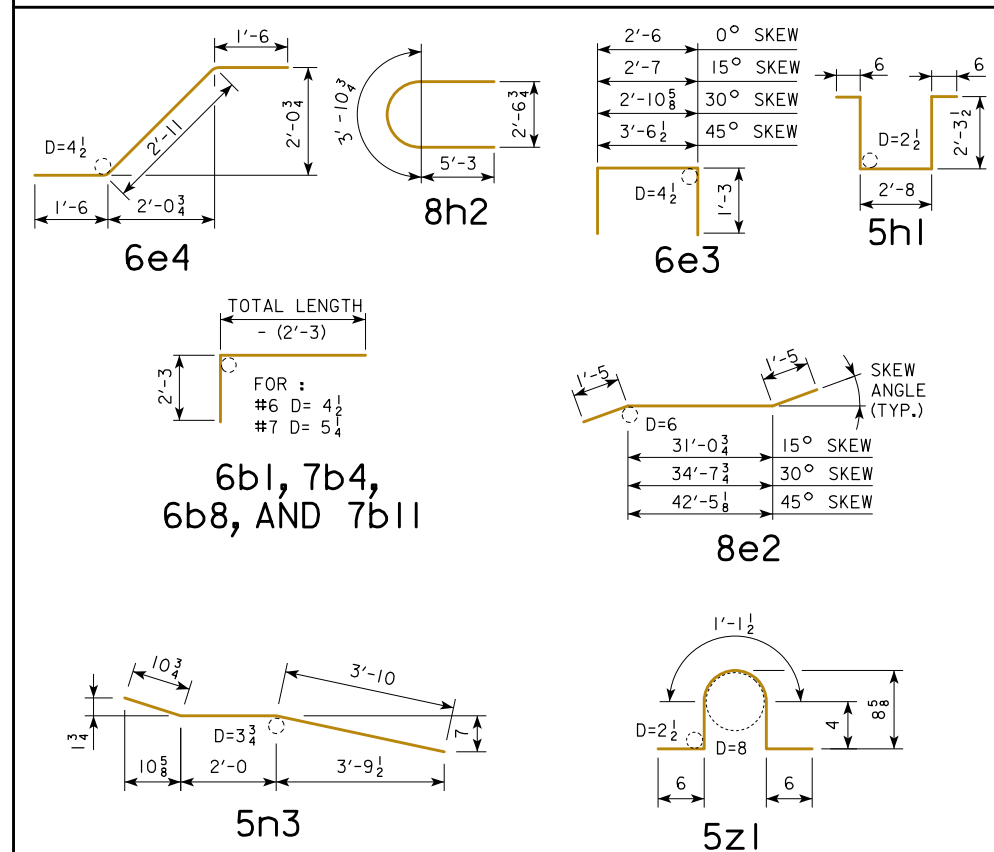

NOTE: ALL DIMENSIONS ARE OUT TO OUT. D = PIN DIAMETER.

09-2020 LATEST REVISION DATE	 APPROVED BY BRIDGE ENGINEER	 STANDARD DESIGN - 30' ROADWAY, 3 SPAN BRIDGES CONTINUOUS CONCRETE SLAB BRIDGES NOVEMBER, 2006	J30-17E-06
		SUPERSTRUCTURE DETAILS 140'-0 BRIDGE	
		EPOXY COATED REINFORCING	

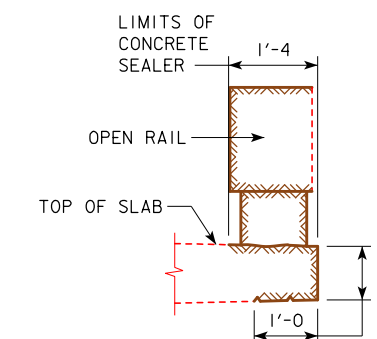
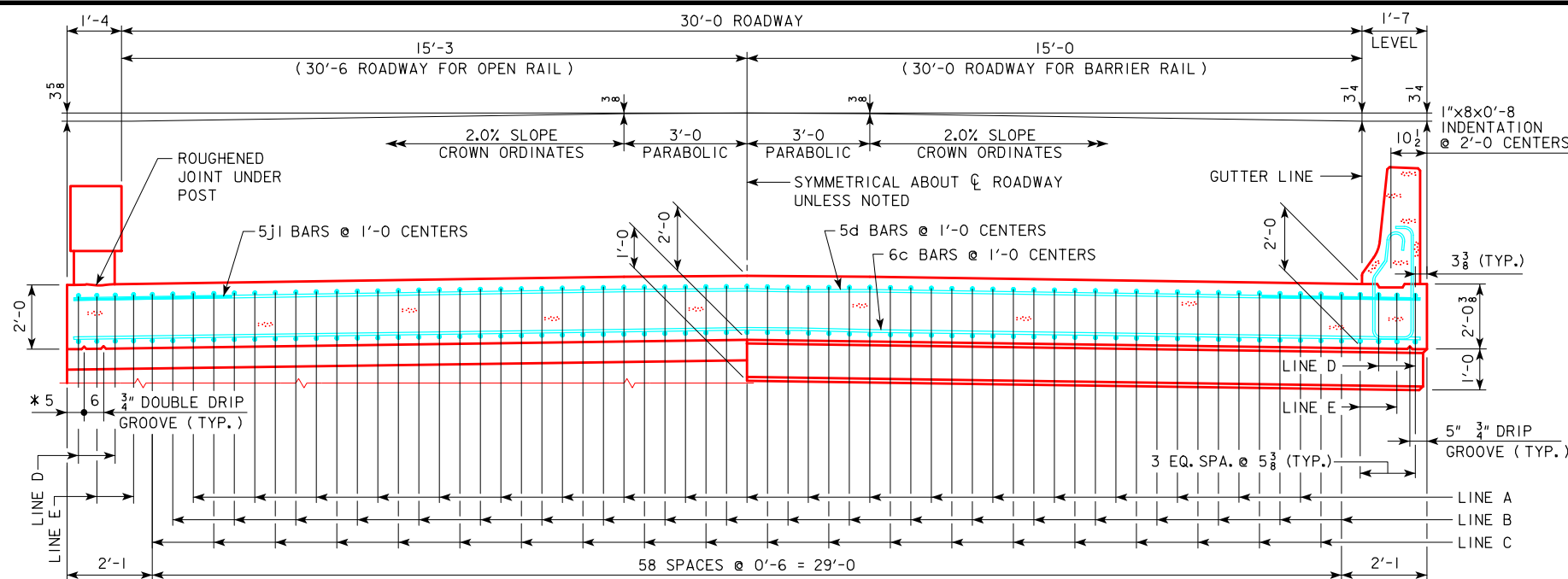

CONCRETE SEALER LIMITS FOR OPEN RAILS

CONCRETE SEALER SHALL BE APPLIED TO BOTH SIDES OF BRIDGE SLAB ON THE TOP, EDGE OF SLAB AND UNDER THE SLAB. THE CONCRETE SEALER SHALL ALSO BE APPLIED TO THE OPEN RAIL ON THE TOP, TRAFFIC FACE SIDE, BOTTOM OF RAIL, AND ON ALL SIDES OF THE OPEN RAIL POSTS.

THE CONCRETE SEALER LIMITS ARE SHOWN IN THE DETAIL AND SHALL APPLY TO THE FULL LENGTH OF BRIDGE. CONCRETE SEALER SHALL BE APPLIED IN ACCORDANCE WITH ARTICLE 2403.03, P, 3 OF THE STANDARD SPECIFICATIONS.

HALF SECTION NEAR ABUTMENT

HALF SECTION NEAR PIER

* NOTE: DOUBLE DRIP GROOVES FOR OPEN RAIL OPTION ONLY.

SLAB CROSS-SECTIONAL AREA FOR OPEN RAIL = 66.34 SQ. FT.

NOTE: TOP LONGITUDINAL REINFORCING STEEL IS TO BE PARALLEL TO AND 2 1/2" CLEAR BELOW TOP OF SLAB. BOTTOM LONGITUDINAL REINFORCING STEEL IS TO BE PARALLEL TO AND 1 1/2" CLEAR ABOVE BOTTOM OF SLAB. REINFORCING STEEL IS TO BE SECURELY WIRED IN PLACE AND ADEQUATELY SUPPORTED ON BAR CHAIRS BEFORE CONCRETE IS POURED. I.M. 451.01 REQUIREMENTS SHALL APPLY FOR BAR CHAIRS.

SLAB CROSS-SECTIONAL AREA FOR BARRIER RAIL = 66.39 SQ. FT.

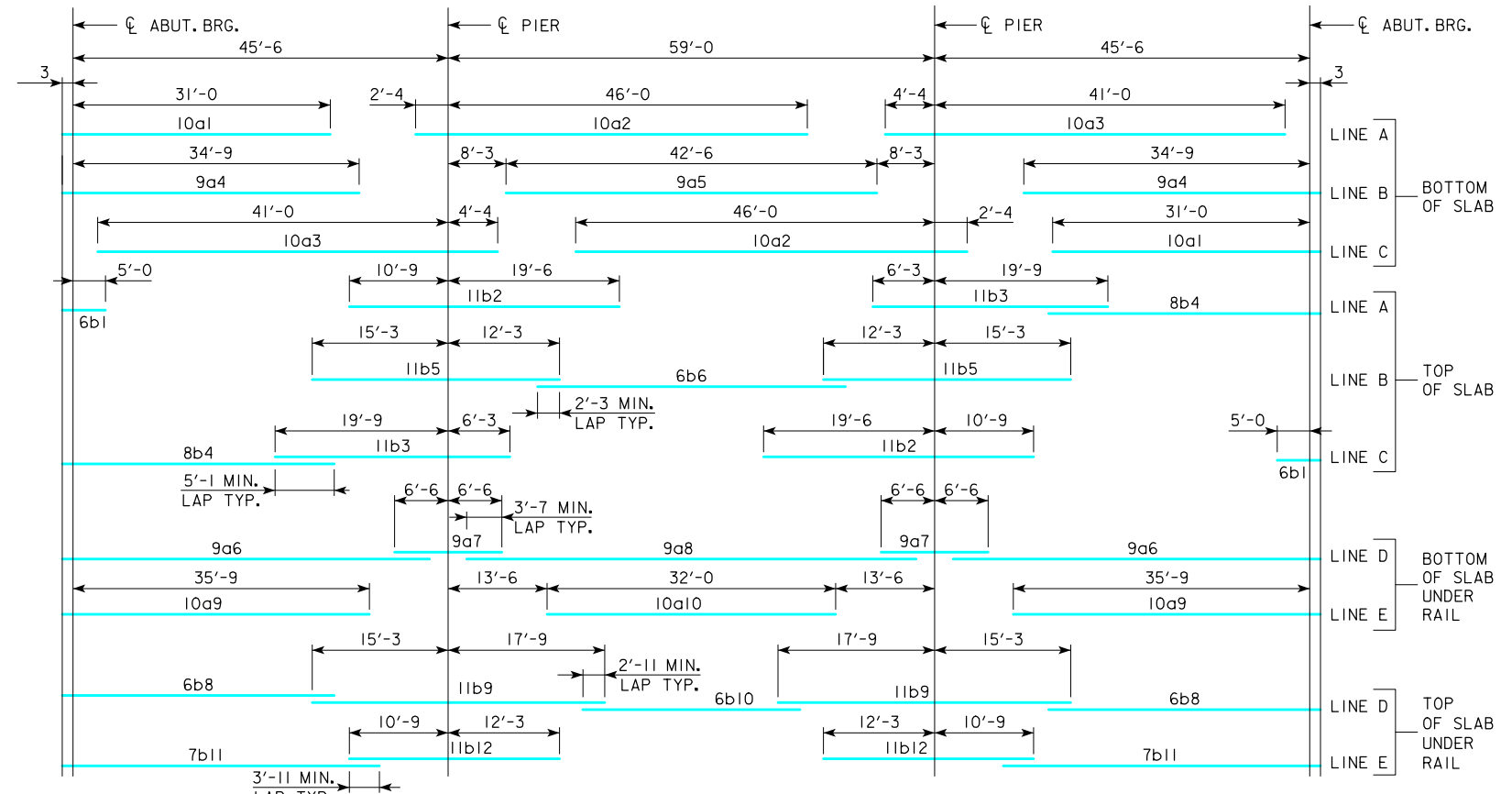

PLACEMENT FOR LONGITUDINAL REINFORCEMENT

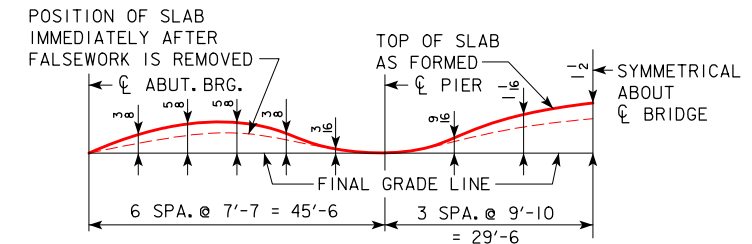

FORM CAMBER DIAGRAM

THIS DIAGRAM SHOWS THE FORM CAMBER REQUIRED TO COMPENSATE FOR THE ANTICIPATED ULTIMATE DEAD LOAD DEFLECTION. THE ABOVE DIMENSIONS DO NOT INCLUDE ANY ALLOWANCE FOR FORM DEFLECTION OR FALSEWORK SETTLEMENT.

REVISED 07-2016; DATE ON SHEET CHANGED TO CORRECT CLERICAL ERROR.
 REVISED 09-2020; UPDATED BRIDGE ENGINEER SIGNATURE.

09-2020 LATEST REVISION DATE	APPROVED BY BRIDGE ENGINEER <i>[Signature]</i>		
		STANDARD DESIGN - 30' ROADWAY, 3 SPAN BRIDGES CONTINUOUS CONCRETE SLAB BRIDGES NOVEMBER, 2006	
		SUPERSTRUCTURE DETAILS 150'-0 BRIDGE	J30-18B-06

NON-EPOXY COATED REINFORCING

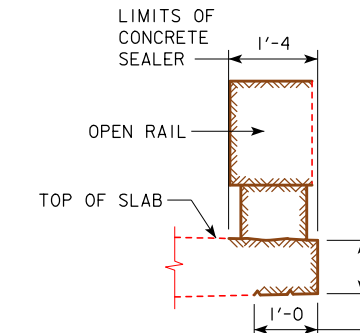
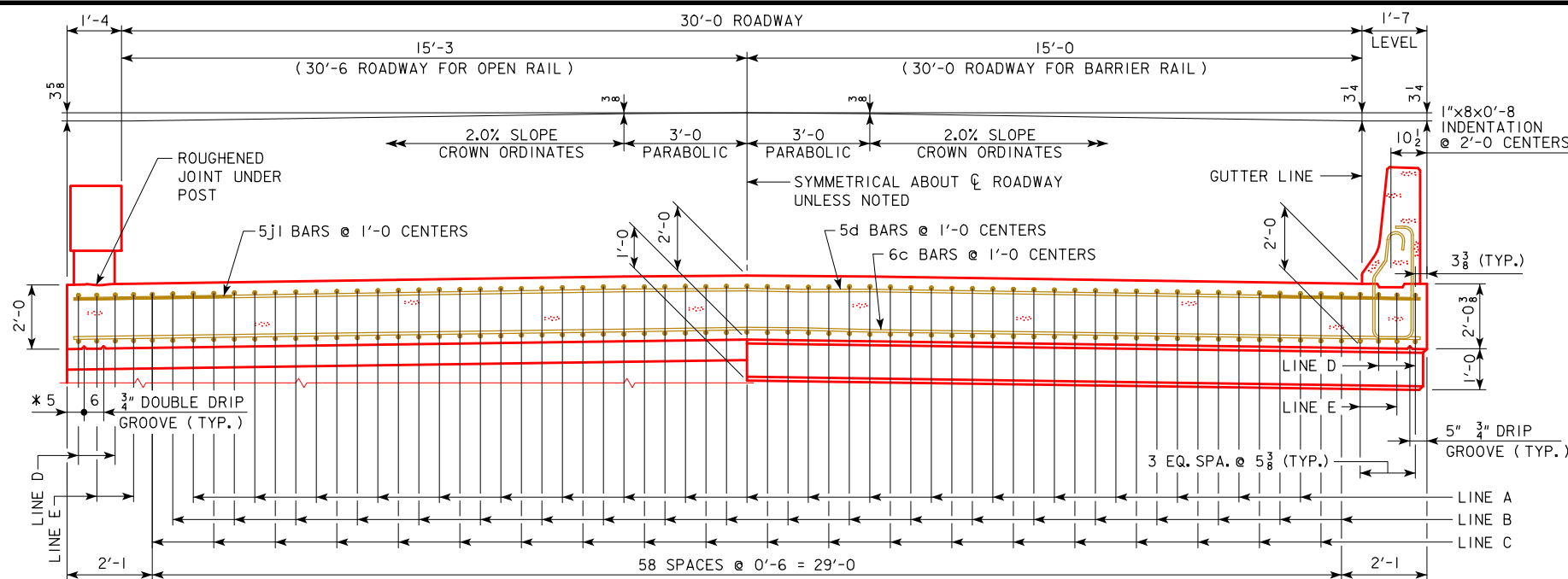

CONCRETE SEALER LIMITS FOR OPEN RAILS

CONCRETE SEALER SHALL BE APPLIED TO BOTH SIDES OF BRIDGE SLAB ON THE TOP, EDGE OF SLAB AND UNDER THE SLAB. THE CONCRETE SEALER SHALL ALSO BE APPLIED TO THE OPEN RAIL ON THE TOP, TRAFFIC FACE SIDE, BOTTOM OF RAIL, AND ON ALL SIDES OF THE OPEN RAIL POSTS.

THE CONCRETE SEALER LIMITS ARE SHOWN IN THE DETAIL AND SHALL APPLY TO THE FULL LENGTH OF BRIDGE. CONCRETE SEALER SHALL BE APPLIED IN ACCORDANCE WITH ARTICLE 2403.03, P, 3 OF THE STANDARD SPECIFICATIONS.

HALF SECTION NEAR ABUTMENT

HALF SECTION NEAR PIER

* NOTE: DOUBLE DRIP GROOVES FOR OPEN RAIL OPTION ONLY.

SLAB CROSS-SECTIONAL AREA FOR OPEN RAIL = 66.33 SQ. FT.

NOTE: TOP LONGITUDINAL REINFORCING STEEL IS TO BE PARALLEL TO AND 2 1/2" CLEAR BELOW TOP OF SLAB. BOTTOM LONGITUDINAL REINFORCING STEEL IS TO BE PARALLEL TO AND 1 1/2" CLEAR ABOVE BOTTOM OF SLAB. REINFORCING STEEL IS TO BE SECURELY WIRED IN PLACE AND ADEQUATELY SUPPORTED ON BAR CHAIRS BEFORE CONCRETE IS POURED. I.M. 451.01 REQUIREMENTS SHALL APPLY FOR BAR CHAIRS.

SLAB CROSS-SECTIONAL AREA FOR BARRIER RAIL = 66.38 SQ. FT.

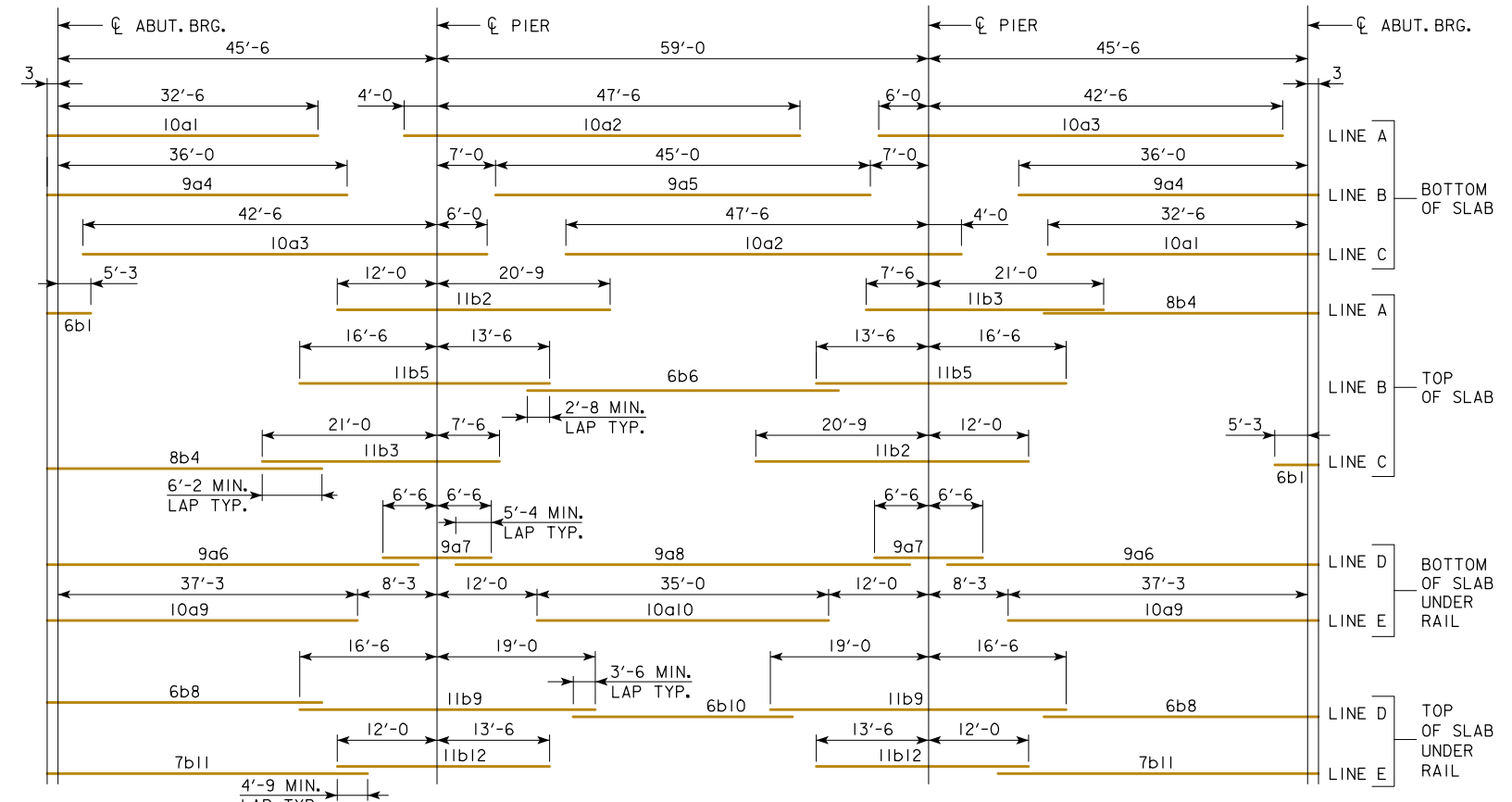

PLACEMENT FOR LONGITUDINAL REINFORCEMENT

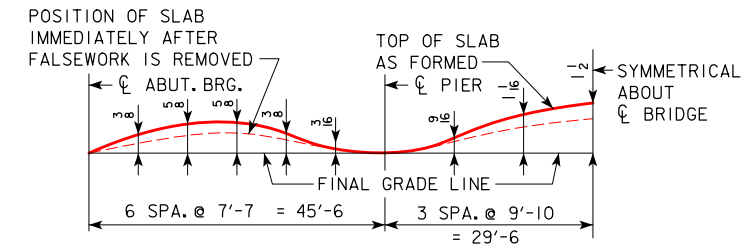

FORM CAMBER DIAGRAM

THIS DIAGRAM SHOWS THE FORM CAMBER REQUIRED TO COMPENSATE FOR THE ANTICIPATED ULTIMATE DEAD LOAD DEFLECTION. THE ABOVE DIMENSIONS DO NOT INCLUDE ANY ALLOWANCE FOR FORM DEFLECTION OR FALSEWORK SETTLEMENT.

REVISED 07-2016; DATE ON SHEET CHANGED TO CORRECT CLERICAL ERROR.
 REVISED 09-2020; UPDATED BRIDGE ENGINEER SIGNATURE.

09-2020 LATEST REVISION DATE	APPROVED BY BRIDGE ENGINEER		
		STANDARD DESIGN - 30' ROADWAY, 3 SPAN BRIDGES CONTINUOUS CONCRETE SLAB BRIDGES NOVEMBER, 2006	
		SUPERSTRUCTURE DETAILS 150'-0 BRIDGE EPOXY COATED REINFORCING	J30-18E-06

BILL OF REINFORCING STEEL FOR SUPERSTRUCTURE - 150' BRIDGE

LOCATION	SKEW	SHAPE	0°				15°				30°				45°			
			NO.	LENGTH	WEIGHT		NO.	LENGTH	WEIGHT		NO.	LENGTH	WEIGHT		NO.	LENGTH	WEIGHT	
SLAB LONGITUDINAL BOTTOM		10a1	39	31'-3	5245	39	31'-3	5245	39	31'-3	5245	39	31'-3	5245				
SLAB LONGITUDINAL BOTTOM, AT RAIL		10a2	39	48'-4	8112	39	48'-4	8112	39	48'-4	8112	39	48'-4	8112				
SLAB LONGITUDINAL BOTTOM, AT RAIL		10a3	39	45'-4	7608	39	45'-4	7608	39	45'-4	7608	39	45'-4	7608				
SLAB LONGITUDINAL BOTTOM, AT RAIL		9a4	40	35'-0	4760	40	35'-0	4760	40	35'-0	4760	40	35'-0	4760				
SLAB LONGITUDINAL BOTTOM, AT RAIL		9a5	20	42'-6	2890	20	42'-6	2890	20	42'-6	2890	20	42'-6	2890				
SLAB LONGITUDINAL BOTTOM, AT RAIL		9a6	8	42'-10	1166	8	42'-10	1166	8	42'-10	1166	8	42'-10	1166				
SLAB LONGITUDINAL BOTTOM, AT RAIL		9a7	8	13'-0	354	8	13'-0	354	8	13'-0	354	8	13'-0	354				
SLAB LONGITUDINAL BOTTOM, AT RAIL		9a8	4	53'-2	724	4	53'-2	724	4	53'-2	724	4	53'-2	724				
SLAB LONGITUDINAL BOTTOM, AT RAIL		10a9	8	36'-0	1240	8	36'-0	1240	8	36'-0	1240	8	36'-0	1240				
SLAB LONGITUDINAL BOTTOM, AT RAIL		10a10	4	32'-0	551	4	32'-0	551	4	32'-0	551	4	32'-0	551				
SLAB LONGITUDINAL TOP		6b1	39	7'-6	440	39	7'-6	440	39	7'-6	440	39	7'-6	440				
SLAB LONGITUDINAL TOP		11b2	39	30'-3	6269	39	30'-3	6269	39	30'-3	6269	39	30'-3	6269				
SLAB LONGITUDINAL TOP		11b3	39	26'-0	5388	39	26'-0	5388	39	26'-0	5388	39	26'-0	5388				
SLAB LONGITUDINAL TOP		8b4	39	33'-4	3471	39	33'-4	3471	39	33'-4	3471	39	33'-4	3471				
SLAB LONGITUDINAL TOP		11b5	40	27'-6	5845	40	27'-6	5845	40	27'-6	5845	40	27'-6	5845				
SLAB LONGITUDINAL TOP		6b6	20	39'-0	1172	20	39'-0	1172	20	39'-0	1172	20	39'-0	1172				
SLAB LONGITUDINAL TOP, AT RAIL		6b8	8	35'-8	429	8	35'-8	429	8	35'-8	429	8	35'-8	429				
SLAB LONGITUDINAL TOP, AT RAIL		11b9	8	33'-0	1403	8	33'-0	1403	8	33'-0	1403	8	33'-0	1403				
SLAB LONGITUDINAL TOP, AT RAIL		6b10	4	29'-4	177	4	29'-4	177	4	29'-4	177	4	29'-4	177				
SLAB LONGITUDINAL TOP, AT RAIL		7b11	8	41'-2	674	8	41'-2	674	8	41'-2	674	8	41'-2	674				
SLAB LONGITUDINAL TOP, AT RAIL		11b12	8	23'-0	978	8	23'-0	978	8	23'-0	978	8	23'-0	978				
SLAB TRANSVERSE, BOTTOM		6c1	147	32'-10	7250	147	34'-0	7507	134	32'-10	6609	120	32'-10	5918				
SLAB TRANSVERSE ENDS, BOTTOM		6c2	-	-	-	-	-	-	30	VARIES	797	56	VARIES	1486				
SLAB TRANSVERSE, TOP		5d1	147	32'-10	5035	147	34'-0	5213	134	32'-10	4589	120	32'-10	4110				
SLAB TRANSVERSE ENDS, TOP		5d2	-	-	-	-	-	-	30	VARIES	553	56	VARIES	1032				
SLAB, TRANSVERSE AT ABUTMENT		8e1	18	32'-10	1578	-	-	-	-	-	-	-	-	-				
SLAB, TRANSVERSE AT ABUTMENT		8e2	-	-	-	18	33'-11	1631	18	37'-6	1803	18	45'-4	2179				
SLAB, HAIRPINS, AT ABUTMENT		6e3	72	5'-0	541	72	5'-1	550	72	5'-5	586	72	6'-1	658				
SLAB, DIAGONALS, AT ABUTMENT		6e4	72	5'-11	640	72	5'-11	640	72	5'-11	640	72	5'-11	640				
PIER CAP HOOPS		5h1	44	8'-6	391	44	8'-6	391	44	8'-6	391	66	8'-6	586				
PIER CAP ENDS		8h2	4	14'-5	154	4	14'-5	154	4	14'-5	154	4	14'-5	154				
PIER CAP, BOTTOM LONGITUDINAL		8h3	8	29'-10	638	8	30'-11	661	8	34'-5	736	8	42'-2	901				
PIER CAP, TOP LONGITUDINAL		8h4	4	32'-10	351	4	34'-0	364	4	37'-11	405	4	46'-6	497				
TOP OF SLAB, TRANSVERSE, AT RAIL		5j1	292	8'-6	2589	292	8'-6	2589	292	8'-6	2589	290	8'-6	2571				
WING, VERTICAL		5m1	40	4'-5	185	40	4'-5	185	40	4'-5	185	40	4'-5	185				
WING, HORIZONTAL BACK FACE		5n1	24	6'-8	167	24	6'-8	167	24	6'-8	167	24	6'-8	167				
WING, HORIZONTAL TRAFFIC FACE		5n3	24	6'-9	169	24	6'-9	169	24	6'-9	169	24	6'-9	169				
PAVING BLOCK LIFTING HOOPS		5z1	10	2'-10	30	10	2'-10	30	10	2'-10	30	10	2'-10	30				
SUB TOTAL - LBS.					78,614			79,147			79,299			80,179				
BARRIER RAIL - SEE LIST ON RAIL SHEET J30-41-06					9161			9161			9161			9161				
OPEN RAIL - SEE LIST ON RAIL SHEET J30-44-06					9605			9605			9605			9605				
TOTAL - LBS.			WITH MONOLITHIC PIER CAP	WITH BARRIER RAIL	87,775			88,308			88,460			89,340				
				WITH OPEN RAIL	88,219			88,752			88,904			89,784				
TOTAL - LBS.			WITH NON-MONOLITHIC PIER CAP	WITH BARRIER RAIL	86,241			86,738			86,774			87,202				
				WITH OPEN RAIL	86,685			87,182			87,218			87,646				

BENT BAR DETAILS

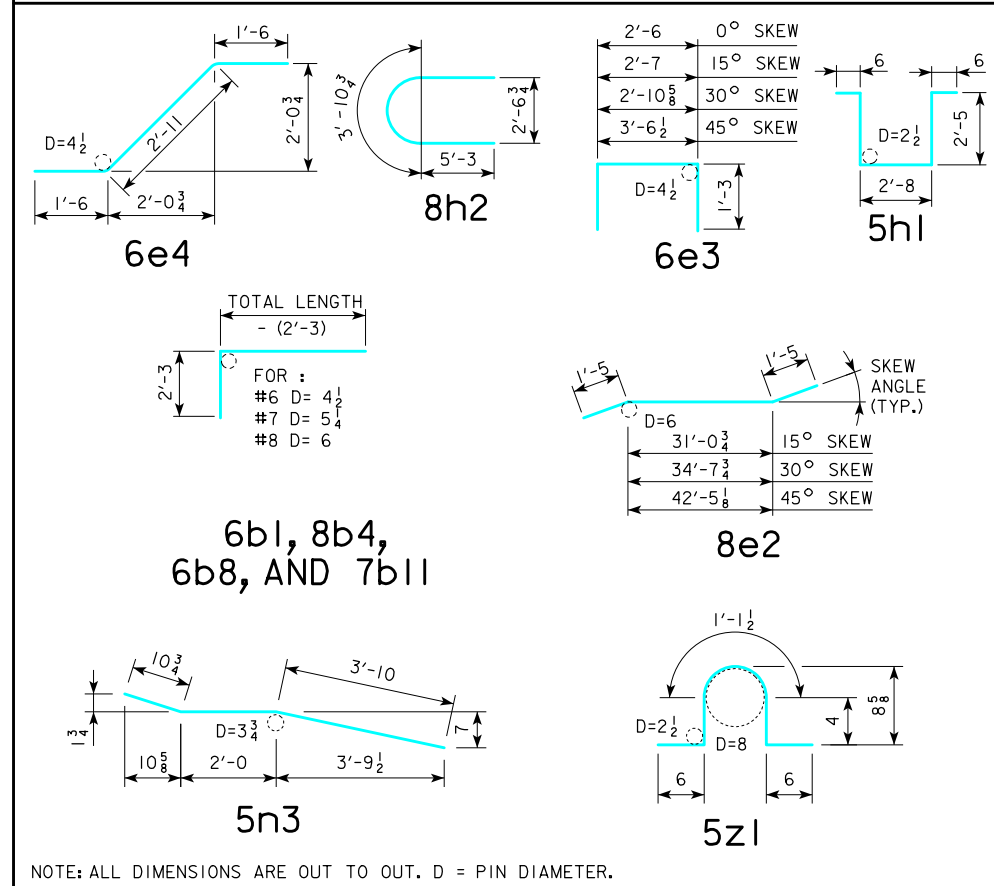

ESTIMATED QUANTITIES FOR SUPERSTRUCTURE - 150' BRIDGE

ITEM	SKEW	WITH MONOLITHIC PIER CAP				WITH NON-MONOLITHIC PIER CAP				
		0°	15°	30°	45°	0°	15°	30°	45°	
WITH BARRIER RAIL	*STRUCTURAL CONCRETE (BRIDGE)	C.Y.	393.1	393.8	396.3	401.6	388.5	389.0	391.0	395.2
CONCRETE BARRIER OR OPEN RAIL	REINFORCING STEEL	LBS.	87,775	88,308	88,460	89,340	86,241	86,738	86,774	87,202
WITH OPEN RAIL	CONCRETE BARRIER OR OPEN RAIL	LIN. FT.	322.0	322.2	322.9	324.5	322.0	322.2	322.9	324.5
WITH OPEN RAIL	*STRUCTURAL CONCRETE (BRIDGE)	C.Y.	392.8	393.5	396.0	401.3	388.2	388.7	390.8	394.9
CONCRETE BARRIER OR OPEN RAIL	REINFORCING STEEL	LBS.	88,219	88,752	88,904	89,784	86,685	87,182	87,218	87,646

* INCLUDES 4 WINGS @ 0.68 C.Y. EACH AND 2 TEMPORARY PAVING BLOCKS; EXCLUDES RAIL CONCRETE.

REVISED 07-2009: OPEN RAIL REINF. QTY'S. CHANGED WHICH CHANGED TOTAL REINF. QTY'S.
REVISED 09-2020: UPDATED BRIDGE ENGINEER SIGNATURE. CHANGED PAVING BLOCK LIFTING HOOP BAR MARK, (WAS 5x1).

09-2020 LATEST REVISION DATE APPROVED BY BRIDGE ENGINEER	 STANDARD DESIGN - 30' ROADWAY, 3 SPAN BRIDGES CONTINUOUS CONCRETE SLAB BRIDGES NOVEMBER, 2006
	SUPERSTRUCTURE DETAILS 150'-0 BRIDGE NON-EPOXY COATED REINFORCING
	J30-19B-06

BILL OF REINFORCING STEEL FOR SUPERSTRUCTURE - 150' BRIDGE

LOCATION	SKEW	SHAPE	BAR	0°				15°				30°				45°			
				NO.	LENGTH	WEIGHT		NO.	LENGTH	WEIGHT		NO.	LENGTH	WEIGHT		NO.	LENGTH	WEIGHT	
SLAB LONGITUDINAL BOTTOM			10a1	39	32'-9	5497		39	32'-9	5497		39	32'-9	5497		39	32'-9	5497	
SLAB LONGITUDINAL BOTTOM			10a2	39	51'-6	8643		39	51'-6	8643		39	51'-6	8643		39	51'-6	8643	
SLAB LONGITUDINAL BOTTOM			10a3	39	48'-6	8140		39	48'-6	8140		39	48'-6	8140		39	48'-6	8140	
SLAB LONGITUDINAL BOTTOM			9a4	40	36'-3	4930		40	36'-3	4930		40	36'-3	4930		40	36'-3	4930	
SLAB LONGITUDINAL BOTTOM			9a5	20	45'-0	3060		20	45'-0	3060		20	45'-0	3060		20	45'-0	3060	
SLAB LONGITUDINAL BOTTOM, AT RAIL			9a6	8	44'-7	1213		8	44'-7	1213		8	44'-7	1213		8	44'-7	1213	
SLAB LONGITUDINAL BOTTOM, AT RAIL			9a7	8	13'-0	354		8	13'-0	354		8	13'-0	354		8	13'-0	354	
SLAB LONGITUDINAL BOTTOM, AT RAIL			9a8	4	56'-8	771		4	56'-8	771		4	56'-8	771		4	56'-8	771	
SLAB LONGITUDINAL BOTTOM, AT RAIL			10a9	8	37'-6	1291		8	37'-6	1291		8	37'-6	1291		8	37'-6	1291	
SLAB LONGITUDINAL BOTTOM, AT RAIL			10a10	4	35'-0	603		4	35'-0	603		4	35'-0	603		4	35'-0	603	
SLAB LONGITUDINAL TOP			6b1	39	7'-9	454		39	7'-9	454		39	7'-9	454		39	7'-9	454	
SLAB LONGITUDINAL TOP			11b2	39	32'-9	6787		39	32'-9	6787		39	32'-9	6787		39	32'-9	6787	
SLAB LONGITUDINAL TOP			11b3	39	28'-6	5906		39	28'-6	5906		39	28'-6	5906		39	28'-6	5906	
SLAB LONGITUDINAL TOP			8b4	39	33'-2	3454		39	33'-2	3454		39	33'-2	3454		39	33'-2	3454	
SLAB LONGITUDINAL TOP			11b5	40	30'-0	6376		40	30'-0	6376		40	30'-0	6376		40	30'-0	6376	
SLAB LONGITUDINAL TOP			6b6	20	37'-4	1122		20	37'-4	1122		20	37'-4	1122		20	37'-4	1122	
SLAB LONGITUDINAL TOP, AT RAIL			6b8	8	35'-0	421		8	35'-0	421		8	35'-0	421		8	35'-0	421	
SLAB LONGITUDINAL TOP, AT RAIL			11b9	8	35'-6	1509		8	35'-6	1509		8	35'-6	1509		8	35'-6	1509	
SLAB LONGITUDINAL TOP, AT RAIL			6b10	4	28'-0	169		4	28'-0	169		4	28'-0	169		4	28'-0	169	
SLAB LONGITUDINAL TOP, AT RAIL			7b11	8	40'-9	667		8	40'-9	667		8	40'-9	667		8	40'-9	667	
SLAB LONGITUDINAL TOP, AT RAIL			11b12	8	25'-6	1084		8	25'-6	1084		8	25'-6	1084		8	25'-6	1084	
SLAB TRANSVERSE, BOTTOM			6c1	147	32'-10	7250		147	34'-0	7507		134	32'-10	6609		120	32'-10	5918	
SLAB TRANSVERSE ENDS, BOTTOM			6c2	-	-	-		-	-	-		30	VARIES	797		56	VARIES	1486	
SLAB TRANSVERSE, TOP			5d1	147	32'-10	5035		147	34'-0	5213		134	32'-10	4589		120	32'-10	4110	
SLAB TRANSVERSE ENDS, TOP			5d2	-	-	-		-	-	-		30	VARIES	553		56	VARIES	1032	
SLAB, TRANSVERSE AT ABUTMENT			8e1	18	32'-10	1578		-	-	-		-	-	-		-	-	-	
SLAB, TRANSVERSE AT ABUTMENT			8e2	-	-	-		18	33'-11	1631		18	37'-6	1803		18	45'-4	2179	
SLAB, HAIRPINS, AT ABUTMENT			6e3	72	5'-0	541		72	5'-1	550		72	5'-5	586		72	6'-1	658	
SLAB, DIAGONALS, AT ABUTMENT			6e4	72	5'-11	640		72	5'-11	640		72	5'-11	640		72	5'-11	640	
PIER CAP HOOPS			5h1	44	8'-6	391		44	8'-6	391		44	8'-6	391		66	8'-6	586	
PIER CAP ENDS			8h2	4	14'-5	154		4	14'-5	154		4	14'-5	154		4	14'-5	154	
PIER CAP, BOTTOM LONGITUDINAL			8h3	8	29'-10	638		8	30'-11	661		8	34'-5	736		8	42'-2	901	
PIER CAP, TOP LONGITUDINAL			8h4	4	32'-10	351		4	34'-0	364		4	37'-11	405		4	46'-6	497	
TOP OF SLAB, TRANSVERSE, AT RAIL			5j1	292	8'-6	2589		292	8'-6	2589		292	8'-6	2589		290	8'-6	2571	
WING, VERTICAL			5m1	40	4'-5	185		40	4'-5	185		40	4'-5	185		40	4'-5	185	
WING, HORIZONTAL BACK FACE			5n1	24	6'-8	167		24	6'-8	167		24	6'-8	167		24	6'-8	167	
WING, HORIZONTAL TRAFFIC FACE			5n3	24	6'-9	169		24	6'-9	169		24	6'-9	169		24	6'-9	169	
** PAVING BLOCK LIFTING HOOPS			5z1	10	2'-10	30		10	2'-10	30		10	2'-10	30		10	2'-10	30	
SUB TOTAL - LBS.						82,169				82,702				82,854				83,734	
BARRIER RAIL - SEE LIST ON RAIL SHEET J30-41-06						9161				9161				9161				9161	
OPEN RAIL - SEE LIST ON RAIL SHEET J30-44-06						9605				9605				9605				9605	
TOTAL - LBS.				WITH MONOLITHIC PIER CAP	WITH BARRIER RAIL	91,330				91,863				92,015				92,895	
				WITH OPEN RAIL		91,774				92,307				92,459				93,339	
TOTAL - LBS.				WITH NON-MONOLITHIC PIER CAP	WITH BARRIER RAIL	89,796				90,293				90,329				90,757	
SAME AS ABOVE EXCEPT ALL "h" BARS DELETED				WITH OPEN RAIL		90,240				90,737				90,773				91,201	

** BARS MAY BE NON-COATED AT CONTRACTOR'S OPTION.

ESTIMATED QUANTITIES FOR SUPERSTRUCTURE - 150' BRIDGE

ITEM	SKEW	WITH MONOLITHIC PIER CAP				WITH NON-MONOLITHIC PIER CAP			
		0°	15°	30°	45°	0°	15°	30°	45°
WITH *STRUCTURAL CONCRETE (BRIDGE) C.Y.		393.1	393.8	396.3	401.6	388.5	389.0	391.0	395.2
BARRIER RAIL REINFORCING STEEL EPOXY COATED LBS.		91,330	91,863	92,015	92,895	89,796	90,293	90,329	90,757
CONCRETE BARRIER OR OPEN RAIL LIN. FT.		322.0	322.2	322.9	324.5	322.0	322.2	322.9	324.5
WITH *STRUCTURAL CONCRETE (BRIDGE) C.Y.		392.8	393.5	396.0	401.3	388.2	388.7	390.8	394.9
OPEN RAIL REINFORCING STEEL EPOXY COATED LBS.		91,774	92,307	92,459	93,339	90,240	90,737	90,773	91,201

* INCLUDES 4 WINGS @ 0.68 C.Y. EACH AND 2 TEMPORARY PAVING BLOCKS; EXCLUDES RAIL CONCRETE.

BENT BAR DETAILS

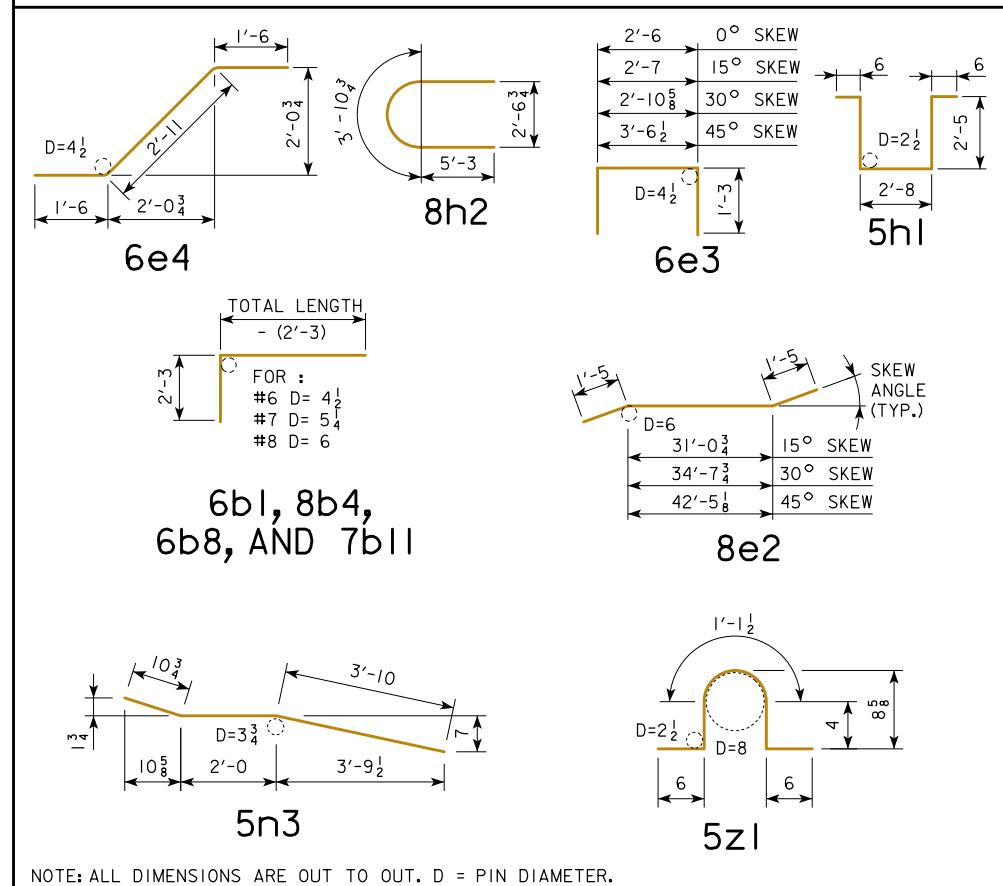

REVISED 07-2009; OPEN RAIL REINF. QTY'S. CHANGED WHICH CHANGED TOTAL REINF. QTY'S.
REVISED 09-2020; UPDATED BRIDGE ENGINEER SIGNATURE. CHANGED PAVING BLOCK LIFTING HOOP BAR MARK, (WAS 5x1).

09-2020
LATEST REVISION DATE

STANDARD DESIGN - 30' ROADWAY, 3 SPAN BRIDGES

CONTINUOUS CONCRETE SLAB BRIDGES

NOVEMBER, 2006

APPROVED BY BRIDGE ENGINEER

SUPERSTRUCTURE DETAILS
150'-0 BRIDGE

EPOXY COATED REINFORCING

J30-19E-06

REVISIONS: 06-2012: I.M. REQUIREMENT ADDED TO BAR CHAIR NOTE. REVISED SUPERSTRUCTURE NOTES TO STATE: "SLAB FALSEWORK SHALL BE REMOVED PRIOR TO CONSTRUCTION OF THE BARRIER RAILS, UNLESS SLAB CONSTRUCTION IS STAGED." CHANGED PAVING BLOCK LIFTING HOOP BAR MARK, (WAS 5x1).
 09-2020: UPDATED BRIDGE ENGINEER SIGNATURE.
 09-2020: I.M. REQUIREMENT ADDED TO BAR CHAIR NOTE. REVISED SUPERSTRUCTURE NOTES TO STATE: "SLAB FALSEWORK SHALL BE REMOVED PRIOR TO CONSTRUCTION OF THE BARRIER RAILS, UNLESS SLAB CONSTRUCTION IS STAGED." CHANGED PAVING BLOCK LIFTING HOOP BAR MARK, (WAS 5x1).

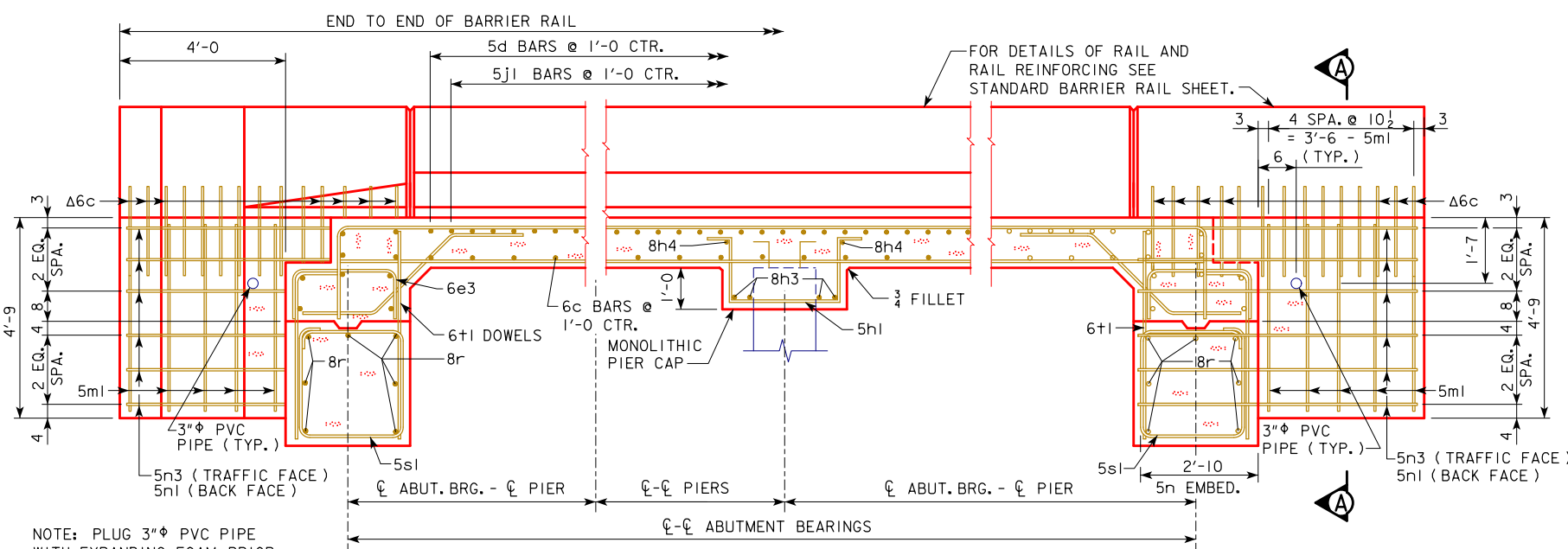

PART LONGITUDINAL SECTION NEAR GUTTER LINE

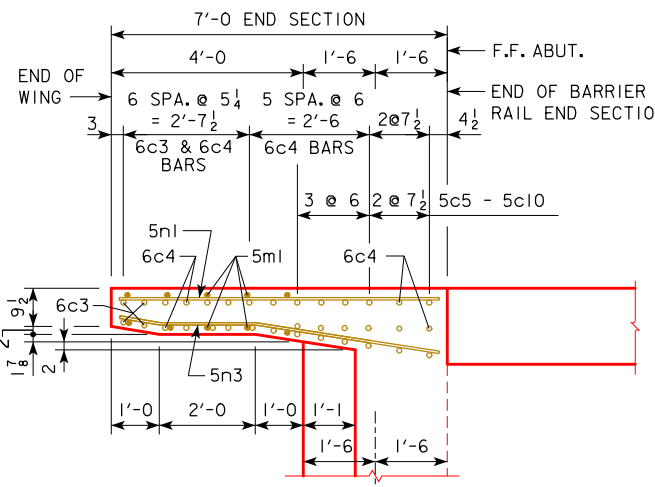

PART PLAN 0° SKEW (RAILING NOT SHOWN)

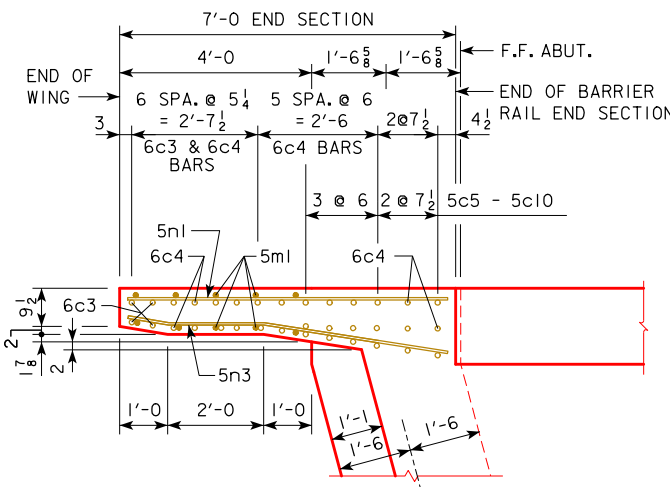

PART PLAN 15° SKEW (RAILING NOT SHOWN)

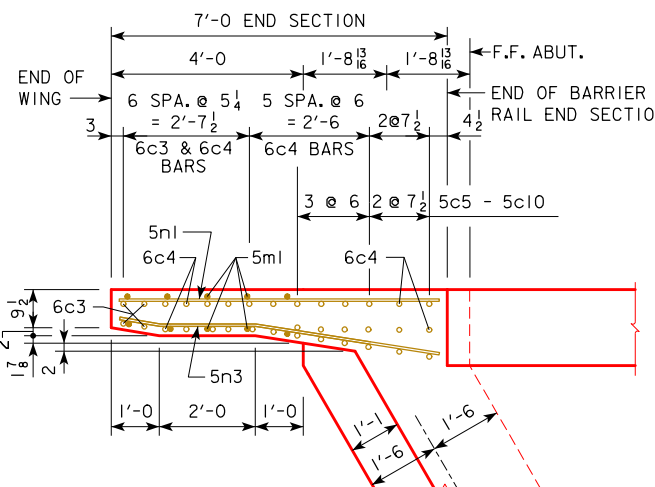

PART PLAN 30° SKEW (RAILING NOT SHOWN)

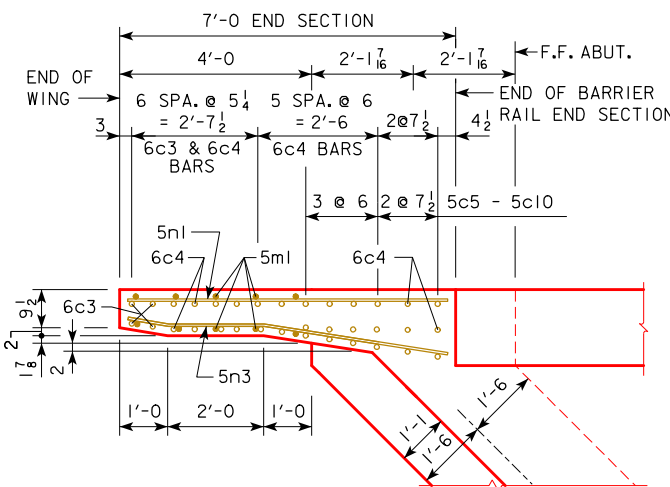

PART PLAN 45° SKEW (RAILING NOT SHOWN)

NOTE: REINFORCING LAYOUT IN PART PLANS 0°, 15°, 30° & 45° SKEWS ARE FOR BARRIER RAIL ONLY. SEE SHEET J30-43-06 FOR OPEN RAIL.

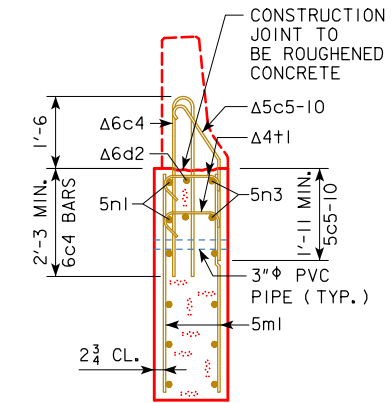

SECTION A-A

NOTE: SEE END SECTION DETAILS IN THESE PLANS FOR DETAILS OF BARRIER RAIL END SECTION. REINFORCING BARS 6c3, 6c4, 5c5-10, 6d2 & 4t1 ARE INCLUDED IN THE SUPERSTRUCTURE QUANTITIES.

NOTE: 5ml, 5n1 & 5n3 BARS ARE INCLUDED IN SUPERSTRUCTURE BAR LIST. 5c, 6c, 6d & 4t1 BARS ARE INCLUDED IN BARRIER RAIL BAR LIST.

SUPERSTRUCTURE NOTES:
 THIS BRIDGE IS DESIGNED FOR HL-93 LOADING PLUS AN ALLOWANCE OF 20 POUNDS PER SQUARE FOOT OF ROADWAY FOR FUTURE WEARING SURFACE.

THE SLAB AS SHOWN INCLUDES A 1/2 INCH INTEGRAL WEARING SURFACE.

THE MINIMUM CLEAR DISTANCE FROM FACE OF CONCRETE TO NEAR REINFORCING BAR SHALL BE 2 INCHES UNLESS OTHERWISE NOTED OR SHOWN. ALL REINFORCING STEEL IS TO BE SECURELY WIRED IN PLACE. SEE "BAR CHAIR NOTE".

ALL REINFORCING SHALL BE GRADE 60.

THE CONCRETE SLAB IS TO BE PLACED WITH A MINIMUM OF CONSTRUCTION JOINTS. PROCEDURES FOR PLACING SLAB CONCRETE SHALL BE SUBMITTED FOR APPROVAL TOGETHER WITH A STATEMENT OF THE PROPOSED METHOD AND EVIDENCE THAT THE CONTRACTOR POSSESSES THE NECESSARY EQUIPMENT AND FACILITIES TO ACCOMPLISH THE REQUIRED RESULT. SLAB FALSEWORK SHALL BE REMOVED PRIOR TO CONSTRUCTION OF THE BARRIER RAILS, UNLESS SLAB CONSTRUCTION IS STAGED.

NOTE THAT WHEN PORTLAND CEMENT APPROACH PAVEMENT IS PLACED, COMPRESSIBLE JOINT MATERIAL MUST BE USED BETWEEN PAVEMENT AND END OF BRIDGE.

COST OF FURNISHING AND PLACING 3"Ø PVC PIPE IN EACH WING IS INCLUDED IN THE PRICE BID FOR STRUCTURAL CONCRETE.

BAR CHAIR NOTE:

TOP MAT OF REINFORCING STEEL IS TO BE SUPPORTED BY INDIVIDUAL BAR CHAIRS SPACED AT NOT MORE THAN 3'-0 CENTERS LONGITUDINALLY AND TRANSVERSELY. THE BOTTOM MAT OF REINFORCING STEEL IS TO BE SUPPORTED BY INDIVIDUAL BAR CHAIRS SPACED AT NOT MORE THAN 3'-0 CENTERS LONGITUDINALLY AND TRANSVERSELY, OR BY CONTINUOUS ROWS OF BAR HIGH CHAIRS OR SLAB BOLSTERS SPACED 4'-0 APART. I.M. 451.01 REQUIREMENTS SHALL APPLY FOR BAR CHAIRS, BAR HIGH CHAIRS, AND SLAB BOLSTERS.

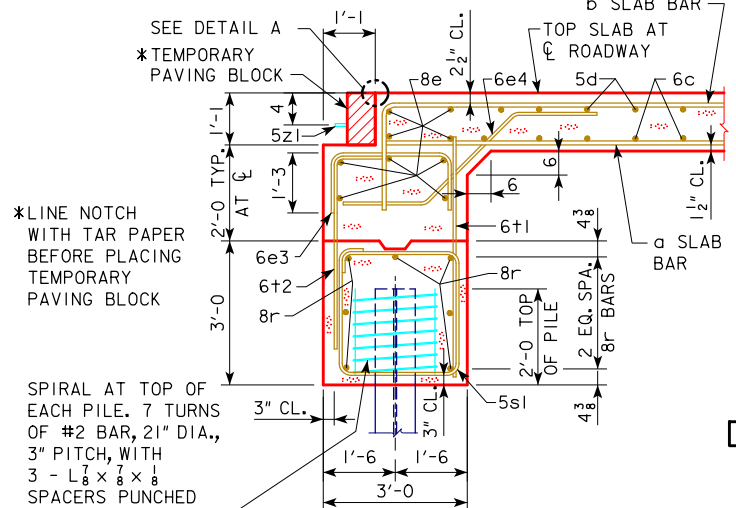

SECTION NORMAL TO ABUTMENT AT CL (BRIDGE LENGTHS 70'-110')

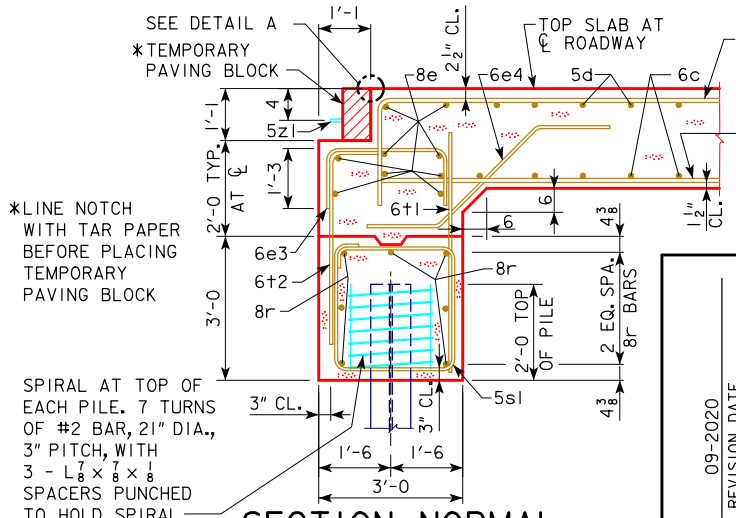

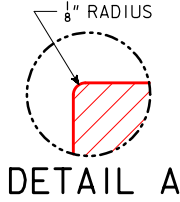

SECTION NORMAL TO ABUTMENT AT CL (BRIDGE LENGTHS 120'-150')

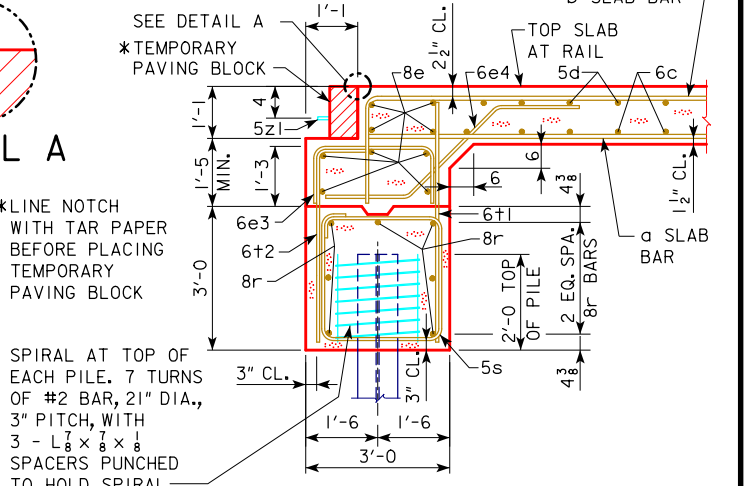

DETAIL A



SECTION NORMAL TO ABUTMENT AT GUTTERLINE

09-2020 LATEST REVISION DATE  APPROVED BY BRIDGE ENGINEER	 STANDARD DESIGN - 30' ROADWAY, 3 SPAN BRIDGES
	CONTINUOUS CONCRETE SLAB BRIDGES NOVEMBER, 2006
	SUPERSTRUCTURE DETAILS ALL BRIDGES

J30-20-06

REVISED 07-2009; CHANGED THE DRAIN ANGLES DETAILS ON SECTION A-A.
REVISED 09-2020; UPDATED BRIDGE ENGINEER SIGNATURE. CHANGED PAVING BLOCK LIFTING HOOP BAR MARK, (WAS 5x1).

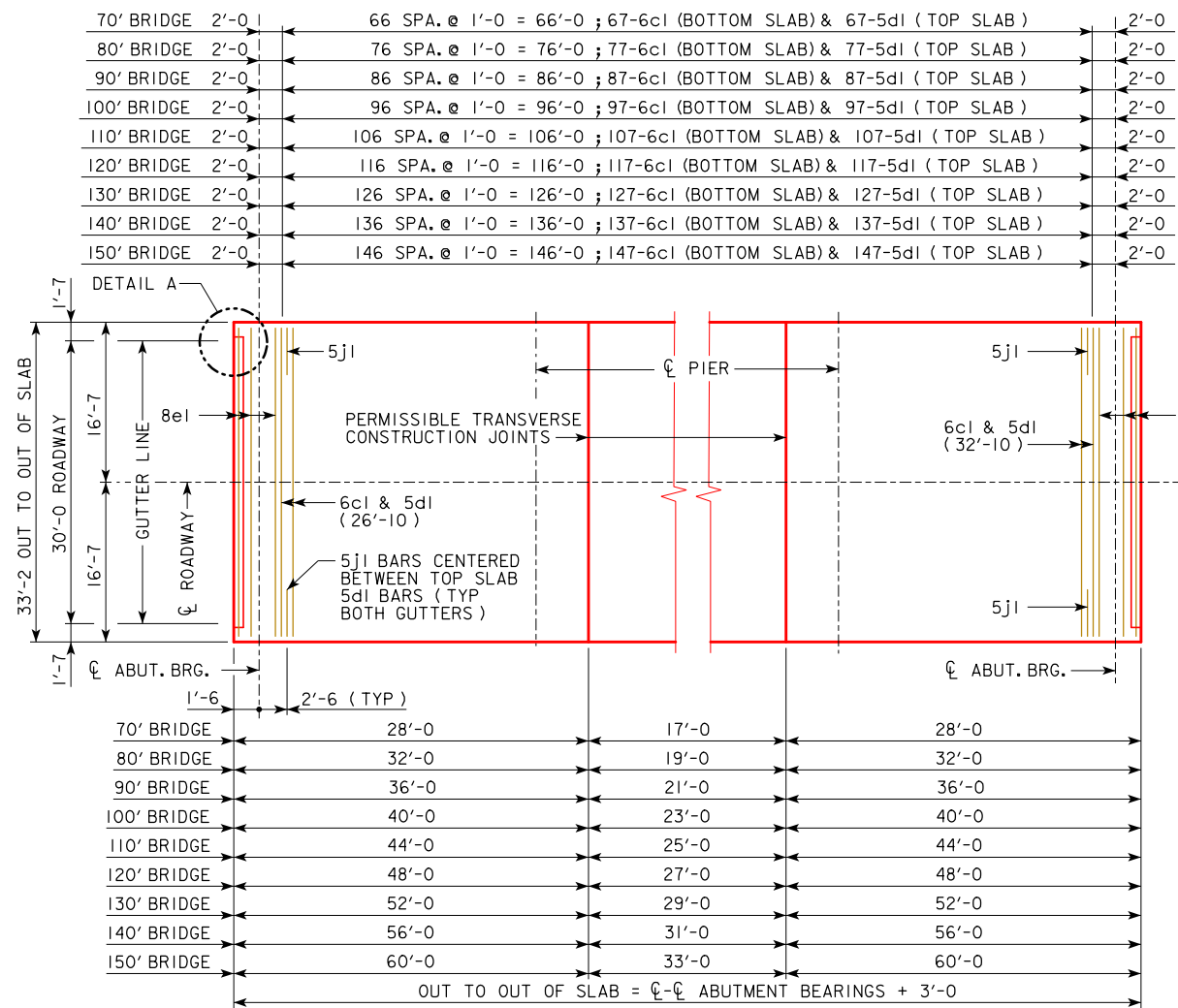

0° SKEW

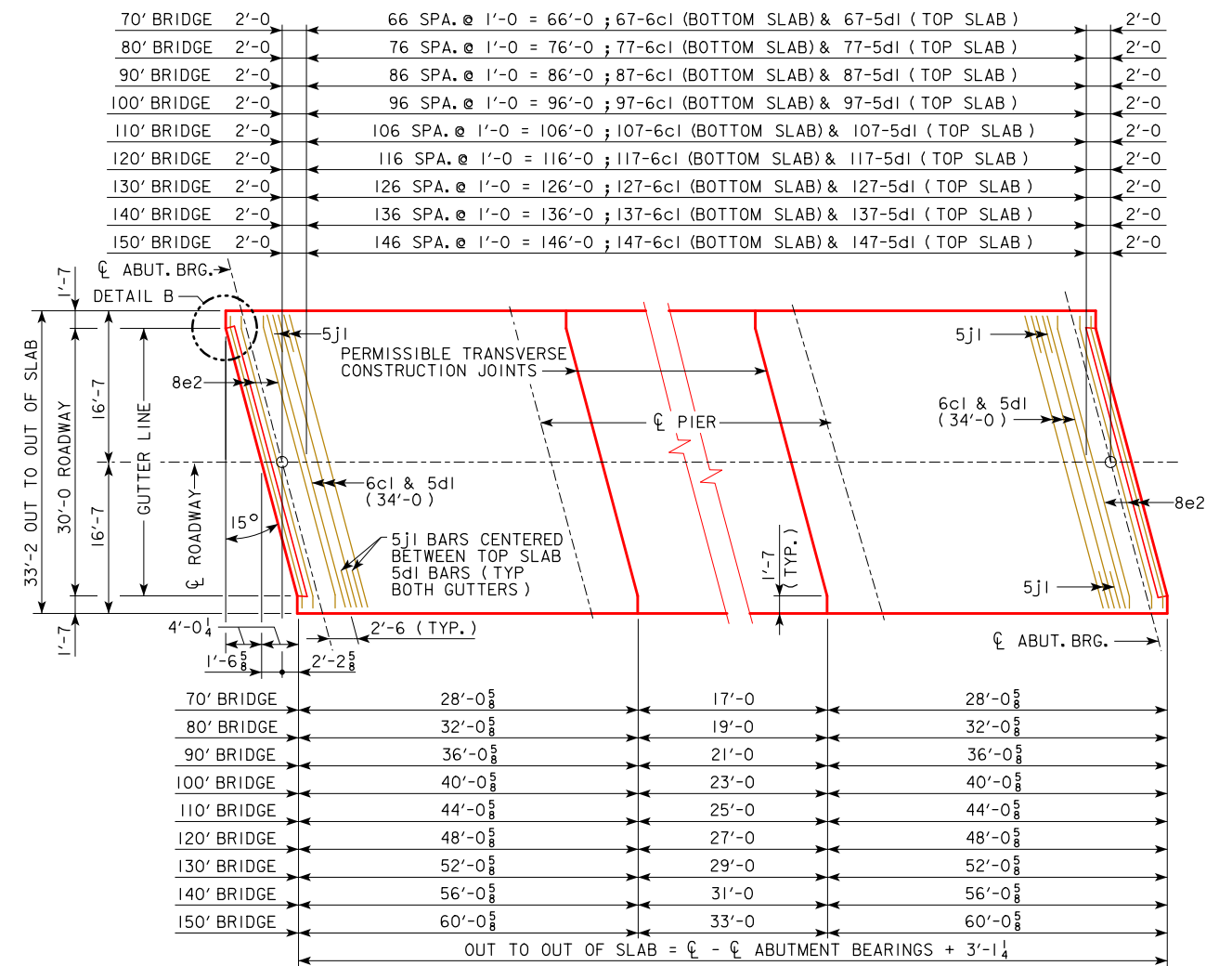

15° SKEW

TRANSVERSE REINFORCING STEEL LAYOUT

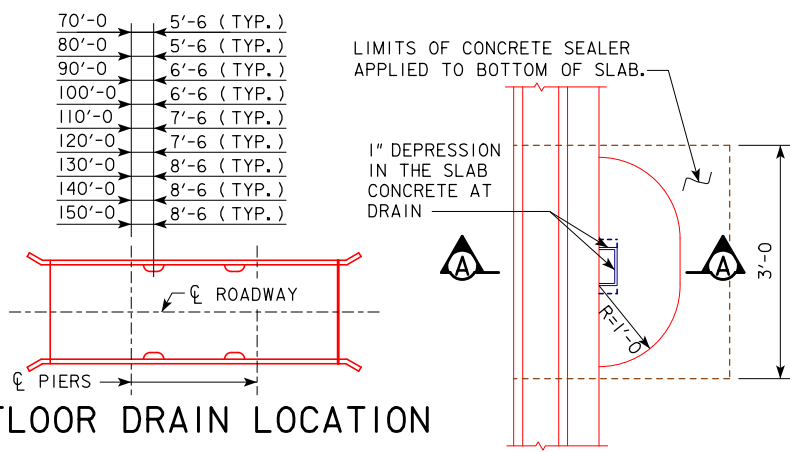

FLOOR DRAIN LOCATION

NOTE: 4" x 8" OUTSIDE DIMENSION ROLLED TUBE WITH 1/4" WALL THICKNESS MAY BE SUBSTITUTED FOR THE WELDED DRAIN SHOWN.

PART PLAN

FLOOR DRAIN DETAILS

(USE FOR BARRIER RAIL ONLY, NOT REQUIRED FOR OPEN RAIL)
NOTE: DRAINS ARE TO BE GALVANIZED. INCLUDE COST OF DRAINS IN PRICE BID FOR "STRUCTURAL CONCRETE". 4 DRAINS REQUIRED.

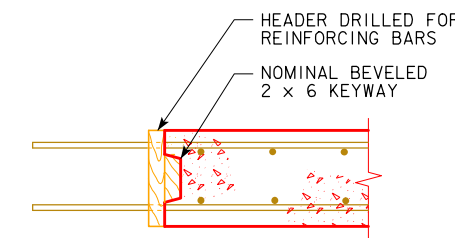
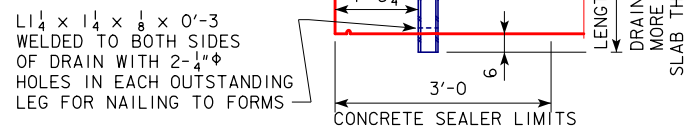
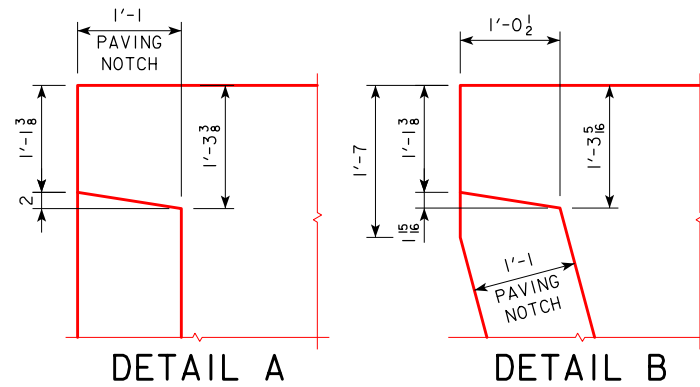

WEIGHT OF ONE FLOOR DRAIN			
SPAN	WEIGHT, LBS.	SPAN	WEIGHT, LBS.
70'-0"	32	120'-0"	41
80'-0"	33	130'-0"	43
90'-0"	35	140'-0"	45
100'-0"	37	150'-0"	48
110'-0"	39		

TEMPORARY PAVING BLOCK		
SKEW	LENGTH	CONCRETE
0°	28'-0"	0.7 C.Y.
15°	29'-0"	0.7 C.Y.

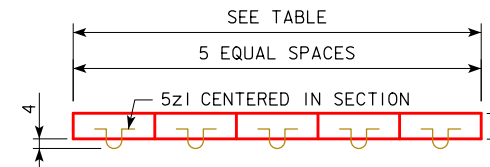

NOTE: TEMPORARY PAVING BLOCK TO BE USED WITH PAVED APPROACHES ONLY. LINE NOTCH WITH TAR PAPER BEFORE PLACING TEMPORARY PAVING BLOCK.

09-2020 LATEST REVISION DATE		APPROVED BY BRIDGE ENGINEER		
			STANDARD DESIGN - 30' ROADWAY, 3 SPAN BRIDGES	
			CONTINUOUS CONCRETE SLAB BRIDGES	
			NOVEMBER, 2006	
SUPERSTRUCTURE DETAILS ALL BRIDGES			J30-21-06	
			0° & 15° SKEW	

REVISED 07-2009; CHANGED THE DRAIN ANGLES DETAILS ON SECTION A-A.
REVISED 09-2020; UPDATED BRIDGE ENGINEER SIGNATURE. CHANGED PAVING BLOCK LIFTING HOOP BAR MARK, (WAS 5x1).

70' BRIDGE	1'-0"	53 SPA. @ 1'-0" = 53'-0" ; 54-6c1 (BOTTOM SLAB) & 54-5d1 (TOP SLAB)	1'-0"
80' BRIDGE	1'-0"	63 SPA. @ 1'-0" = 63'-0" ; 64-6c1 (BOTTOM SLAB) & 64-5d1 (TOP SLAB)	1'-0"
90' BRIDGE	1'-0"	73 SPA. @ 1'-0" = 73'-0" ; 74-6c1 (BOTTOM SLAB) & 74-5d1 (TOP SLAB)	1'-0"
100' BRIDGE	1'-0"	83 SPA. @ 1'-0" = 83'-0" ; 84-6c1 (BOTTOM SLAB) & 84-5d1 (TOP SLAB)	1'-0"
110' BRIDGE	1'-0"	93 SPA. @ 1'-0" = 93'-0" ; 94-6c1 (BOTTOM SLAB) & 94-5d1 (TOP SLAB)	1'-0"
120' BRIDGE	1'-0"	103 SPA. @ 1'-0" = 103'-0" ; 104-6c1 (BOTTOM SLAB) & 104-5d1 (TOP SLAB)	1'-0"
130' BRIDGE	1'-0"	113 SPA. @ 1'-0" = 113'-0" ; 114-6c1 (BOTTOM SLAB) & 114-5d1 (TOP SLAB)	1'-0"
140' BRIDGE	1'-0"	123 SPA. @ 1'-0" = 123'-0" ; 124-6c1 (BOTTOM SLAB) & 124-5d1 (TOP SLAB)	1'-0"
150' BRIDGE	1'-0"	133 SPA. @ 1'-0" = 133'-0" ; 134-6c1 (BOTTOM SLAB) & 134-5d1 (TOP SLAB)	1'-0"

70' BRIDGE	1'-0"	39 SPA. @ 1'-0" = 39'-0" ; 40-6c1 (BOTT. SLAB) & 40-5d1 (TOP SLAB)	1'-0"
80' BRIDGE	1'-0"	49 SPA. @ 1'-0" = 49'-0" ; 50-6c1 (BOTT. SLAB) & 50-5d1 (TOP SLAB)	1'-0"
90' BRIDGE	1'-0"	59 SPA. @ 1'-0" = 59'-0" ; 60-6c1 (BOTT. SLAB) & 60-5d1 (TOP SLAB)	1'-0"
100' BRIDGE	1'-0"	69 SPA. @ 1'-0" = 69'-0" ; 70-6c1 (BOTT. SLAB) & 70-5d1 (TOP SLAB)	1'-0"
110' BRIDGE	1'-0"	79 SPA. @ 1'-0" = 79'-0" ; 80-6c1 (BOTT. SLAB) & 80-5d1 (TOP SLAB)	1'-0"
120' BRIDGE	1'-0"	89 SPA. @ 1'-0" = 89'-0" ; 90-6c1 (BOTT. SLAB) & 90-5d1 (TOP SLAB)	1'-0"
130' BRIDGE	1'-0"	99 SPA. @ 1'-0" = 99'-0" ; 100-6c1 (BOTT. SLAB) & 100-5d1 (TOP SLAB)	1'-0"
140' BRIDGE	1'-0"	109 SPA. @ 1'-0" = 109'-0" ; 110-6c1 (BOTT. SLAB) & 110-5d1 (TOP SLAB)	1'-0"
150' BRIDGE	1'-0"	119 SPA. @ 1'-0" = 119'-0" ; 120-6c1 (BOTT. SLAB) & 120-5d1 (TOP SLAB)	1'-0"

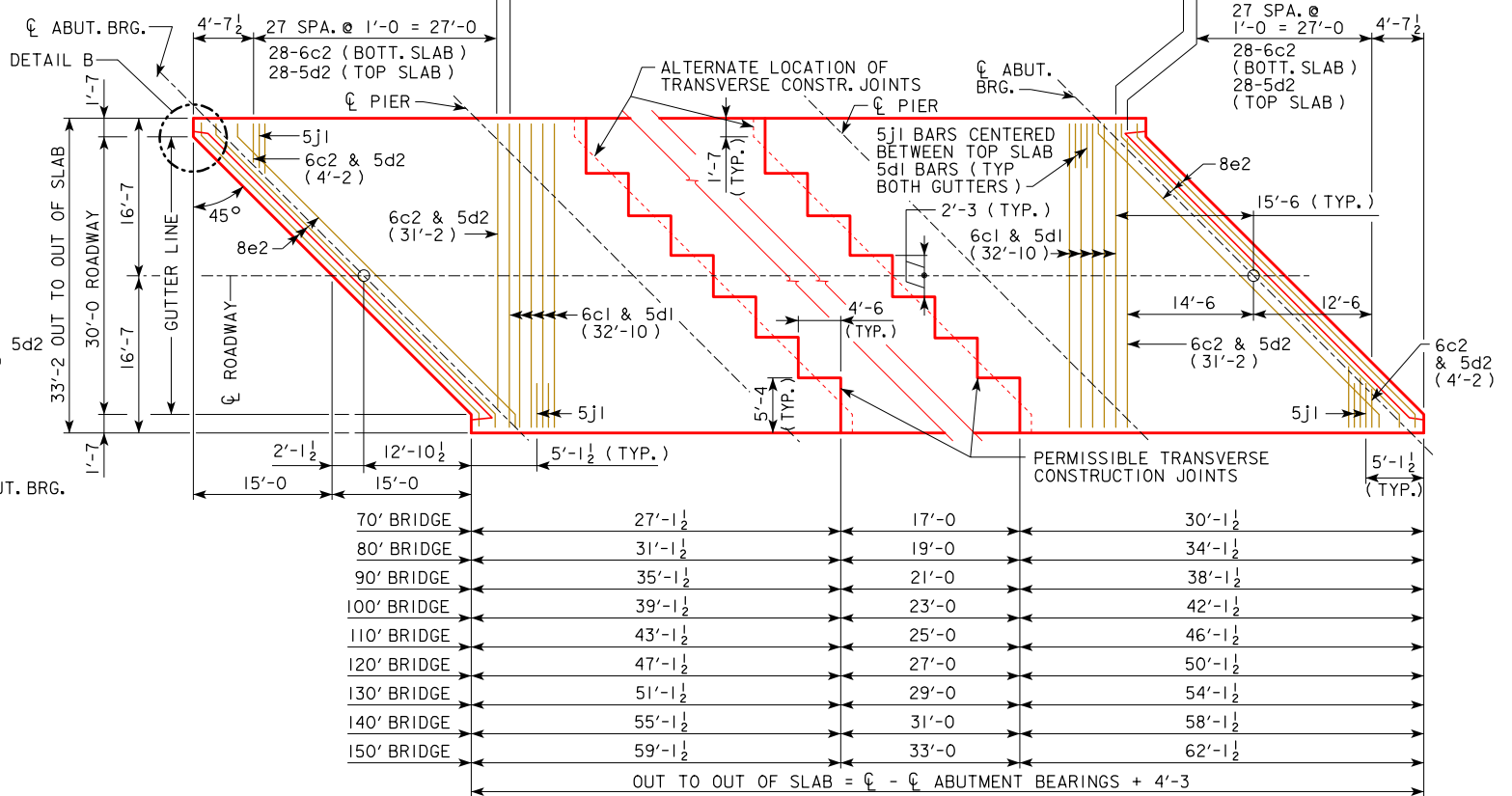
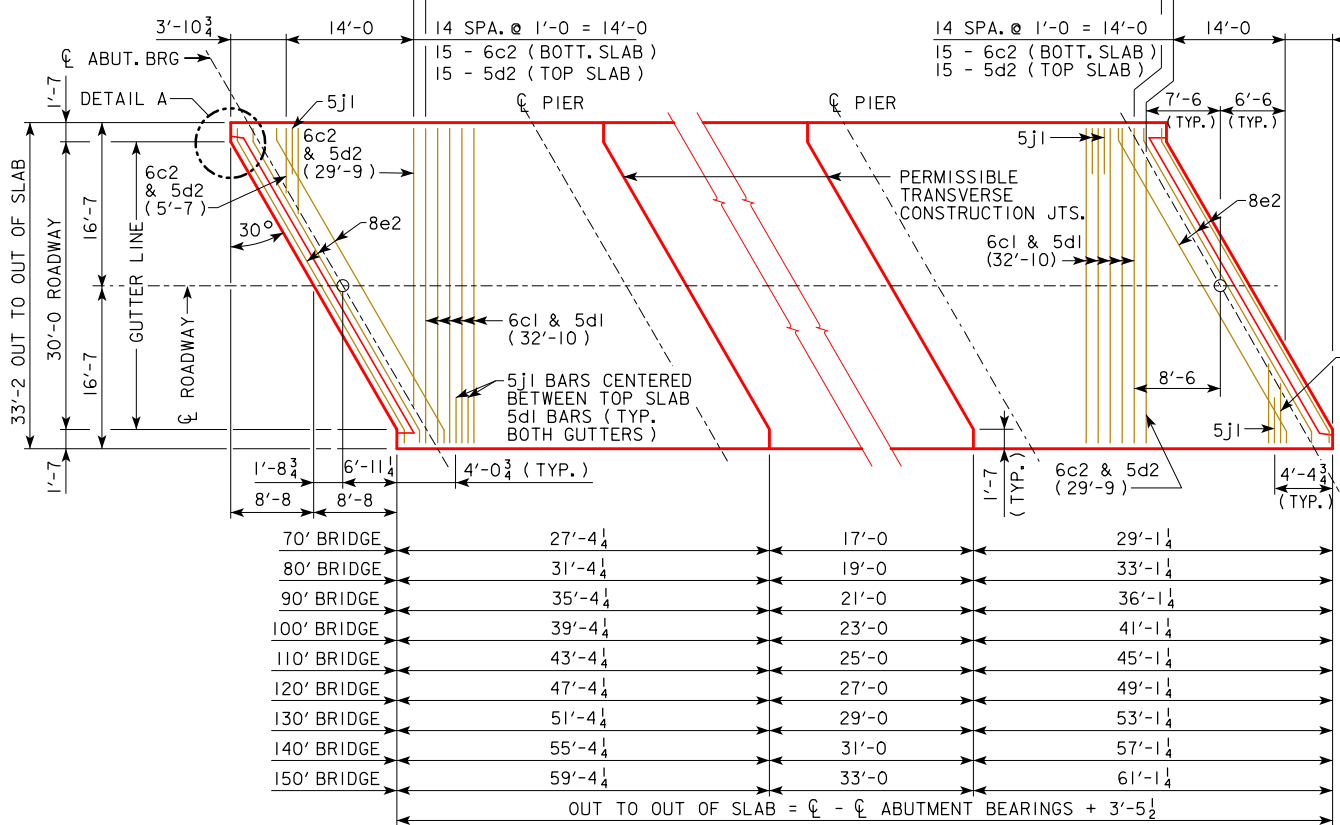

30° SKEW

TRANSVERSE REINFORCING STEEL LAYOUT

45° SKEW

NOTE: 5d2 BARS ARE TO PASS UNDER 8e2 BARS IN CONFLICT AREAS ON 30° & 45° SKEW BRIDGES.

TEMPORARY PAVING BLOCK		
SKEW	LENGTH	CONCRETE
30°	32'-7"	0.8 C.Y.
45°	40'-5"	0.9 C.Y.

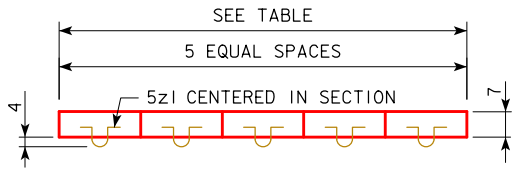

TEMPORARY PAVING BLOCK DETAIL

NOTE: TEMPORARY PAVING BLOCK TO BE USED WITH PAVED APPROACHES ONLY. LINE NOTCH WITH TAR PAPER BEFORE PLACING TEMPORARY PAVING BLOCK.

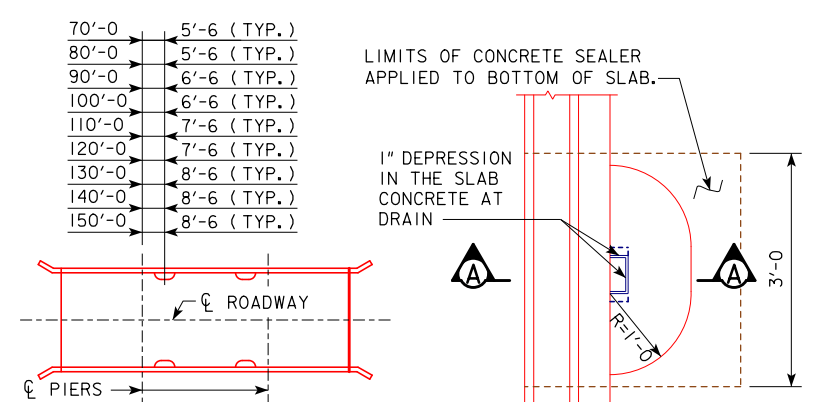

FLOOR DRAIN LOCATION

NOTE: 4" x 8" OUTSIDE DIMENSION ROLLED TUBE WITH 1/4" WALL THICKNESS MAY BE SUBSTITUTED FOR THE WELDED DRAIN SHOWN.

FLOOR DRAIN DETAILS

(USE FOR BARRIER RAIL ONLY, NOT REQUIRED FOR OPEN RAIL)
NOTE: DRAINS ARE TO BE GALVANIZED. INCLUDE COST OF DRAINS IN PRICE BID FOR "STRUCTURAL CONCRETE". 4 DRAINS REQUIRED.

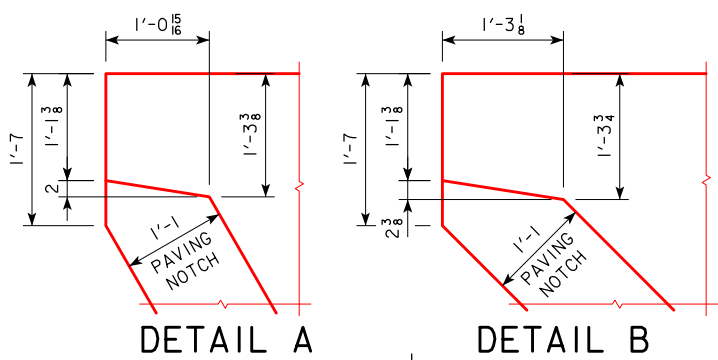
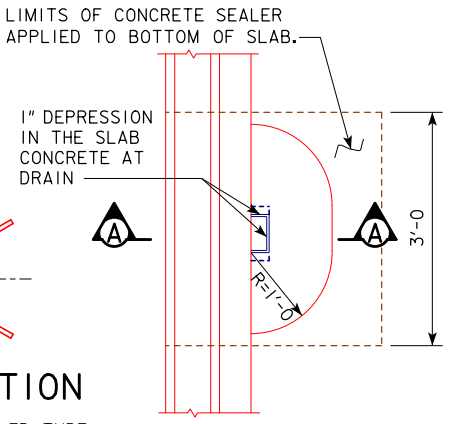

DETAIL A

DETAIL B

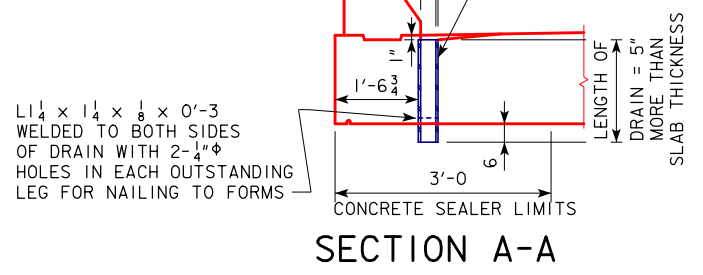

SECTION A-A

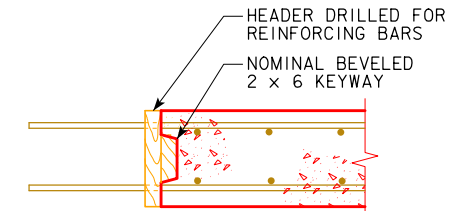

TRANSVERSE CONSTRUCTION JOINT

WEIGHT OF ONE FLOOR DRAIN			
SPAN	WEIGHT, LBS.	SPAN	WEIGHT, LBS.
70'-0"	32	120'-0"	41
80'-0"	33	130'-0"	43
90'-0"	35	140'-0"	45
100'-0"	37	150'-0"	48
110'-0"	39		

09-2020
LATEST REVISION DATE

APPROVED BY BRIDGE ENGINEER



STANDARD DESIGN - 30' ROADWAY, 3 SPAN BRIDGES

CONTINUOUS CONCRETE SLAB BRIDGES

NOVEMBER, 2006

SUPERSTRUCTURE DETAILS
ALL BRIDGES

J30-22-06

30° & 45° SKEW

REVISED 05-2014: CHANGED THE BAR LABEL FROM 5d1 TO 5h1 IN ENCIRCLED NOTE 1.
REVISED 09-2020: UPDATED BRIDGE ENGINEER SIGNATURE.

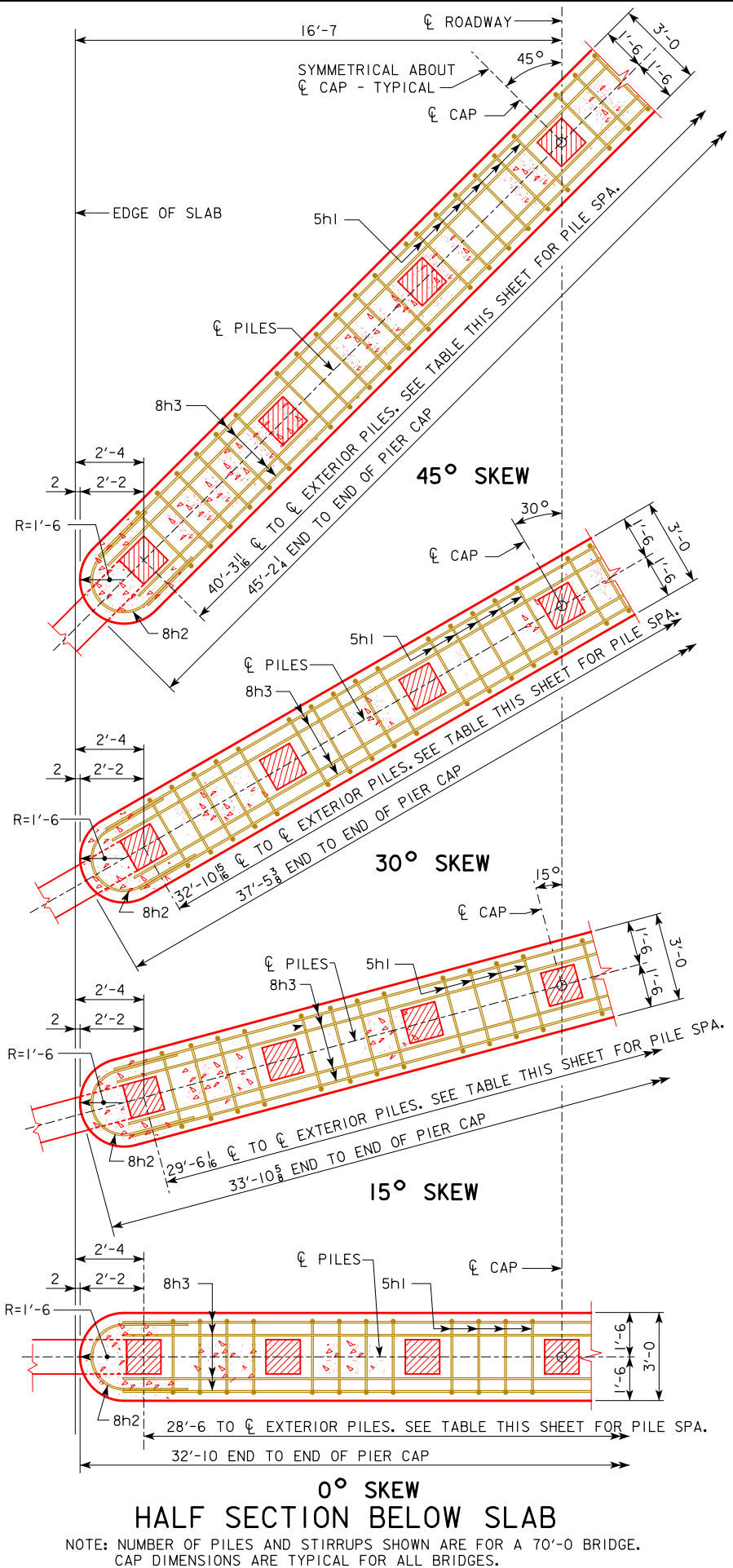

TYPICAL NUMBERS OF PILES AND SPACINGS AND FACTORED PIER LOADS

BRIDGE LENGTH	70'-0	80'-0	90'-0	100'-0	110'-0	120'-0	130'-0	140'-0	150'-0
① TYP. NO. OF PILES	7	7	8	9	10	11	12	12	12
TYP. PILE SPACES @ 0°	6 SPA. @ 4'-9	6 SPA. @ 4'-9	7 SPA. @ ABOUT 4'-1(-)	8 SPA. @ ABOUT 3'-7(-)	② 9 SPA. @ 3'-2	③ 10 SPA. @ ABOUT 2'-10(+)	③ 11 SPA. @ ABOUT 2'-7(+)	③ 11 SPA. @ ABOUT 2'-7(+)	③ 11 SPA. @ ABOUT 2'-7(+)
TYP. PILE SPACES @ 15°	6 SPA. @ ABOUT 4'-11(+)	6 SPA. @ ABOUT 4'-11(+)	7 SPA. @ ABOUT 4'-3(-)	8 SPA. @ ABOUT 3'-8(+)	② 9 SPA. @ ABOUT 3'-3(+)	② 10 SPA. @ ABOUT 2'-11(+)	③ 11 SPA. @ ABOUT 2'-8(+)	③ 11 SPA. @ ABOUT 2'-8(+)	③ 11 SPA. @ ABOUT 2'-8(+)
TYP. PILE SPACES @ 30°	6 SPA. @ ABOUT 5'-6(-)	6 SPA. @ ABOUT 5'-6(-)	7 SPA. @ ABOUT 4'-8(+)	8 SPA. @ ABOUT 4'-1(+)	9 SPA. @ ABOUT 3'-8(-)	② 10 SPA. @ ABOUT 3'-3(+)	② 11 SPA. @ ABOUT 3'-0(-)	② 11 SPA. @ ABOUT 3'-0(-)	② 11 SPA. @ ABOUT 3'-0(-)
TYP. PILE SPACES @ 45°	6 SPA. @ ABOUT 6'-9(-)	6 SPA. @ ABOUT 6'-9(-)	7 SPA. @ ABOUT 5'-9(+)	8 SPA. @ ABOUT 5'-0(+)	9 SPA. @ ABOUT 4'-6(-)	10 SPA. @ ABOUT 4'-0(+)	11 SPA. @ ABOUT 3'-8(-)	11 SPA. @ ABOUT 3'-8(-)	11 SPA. @ ABOUT 3'-8(-)
④ PU, STRENGTH I DESIGN LOAD FOR PIER (KIPS)	631 KIPS	699 KIPS	776 KIPS	860 KIPS	942 KIPS	1039 KIPS	1134 KIPS	1234 KIPS	1346 KIPS

- ① THIS TYPICAL NUMBER OF PILES MAY NEED TO BE MODIFIED DEPENDING ON SELECTED PIER PILE TYPE AND SIZE, HEIGHT, AND RESISTANCE. IF THE NUMBER OF PILES IS DIFFERENT THAN IN THE TABLE FOR THE BRIDGE LENGTH, THE NUMBER OF 5h1 BARS AND OTHER QUANTITIES NEED TO BE CHECKED AND ADJUSTED AS NEEDED. PILES 10 INCHES AND 12 INCHES IN SIZE MUST BE SPACED 2'-6 OR MORE, PILES 14 INCHES IN SIZE MUST BE SPACED 2'-11 OR MORE, AND PILES 16 INCHES IN SIZE MUST BE SPACED 3'-4 OR MORE.
- ② MAXIMUM PIER PILE SIZE AT THIS SPACING IS 14 INCHES.
- ③ MAXIMUM PIER PILE SIZE AT THIS SPACING IS 12 INCHES.
- ④ STRENGTH I PIER DESIGN LOAD INCLUDES DYNAMIC LOAD ALLOWANCE (1M), AND PIER CAP WEIGHT IS BASED ON 45° SKEW. USE THIS PU FOR DETERMINING NUMBER OF PILES AND PILE LENGTH.

PIER NOTES:

ALL MONOLITHIC PIER CAP REINFORCING AND CONCRETE IS INCLUDED IN SUPERSTRUCTURE ESTIMATE OF QUANTITIES.

THE MINIMUM CLEAR DISTANCE FROM THE FACE OF THE CONCRETE TO NEAR REINFORCING BAR IS TO BE 2" UNLESS OTHERWISE NOTED OR SHOWN.

THE PIER PILES ARE TO BE DRIVEN TO FULL PENETRATION, IF PRACTICABLE, BUT IN NO CASE TO A BEARING VALUE LESS THAN THE PILE BEARING REQUIRED FOR EACH BRIDGE LENGTH AS SHOWN ON THIS SHEET. ADDITIONAL DRIVING CAPACITY MAY BE REQUIRED THROUGH SCOURABLE LAYERS. REFER TO GENERAL PLAN NOTES FOR ADDITIONAL INFORMATION.

CAP STEEL AS DETAILED ON PIER STANDARD PILE DRAWING IS REQUIRED FOR MONOLITHIC PIER CAPS.

THE CONCRETE QUANTITIES ARE BASED ON THE USE OF TYPE 3 PILING. IF TYPE 1 OR TYPE 2 IS USED, THE CONCRETE QUANTITIES MAY BE ADJUSTED TO ACCOUNT FOR THE CONCRETE DISPLACED BY THE PILING.

ALL REINFORCING STEEL IS TO BE GRADE 60.

PIER PILING WAS DESIGNED FOR HL-93 LOADING WITH AN ALLOWANCE FOR 20 LBS. PER SQ. FT. FUTURE WEARING SURFACE.

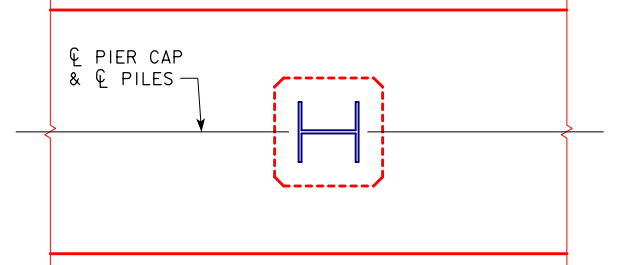

PILE ORIENTATION DETAIL FOR TYPE 3 TRESTLE BENT PILES

09-2020 LATEST REVISION DATE APPROVED BY BRIDGE ENGINEER	STANDARD DESIGN - 30' ROADWAY, 3 SPAN BRIDGES CONTINUOUS CONCRETE SLAB BRIDGES NOVEMBER, 2006	J30-23-06 SHEET 1 OF 2
	MONOLITHIC PIER CAP DETAILS ALL BRIDGES	

REVISED 07-2009; CHANGED THE DRAIN ANGLES DETAILS ON SECTION A-A.
 REVISED 09-2020; UPDATED BRIDGE ENGINEER SIGNATURE.

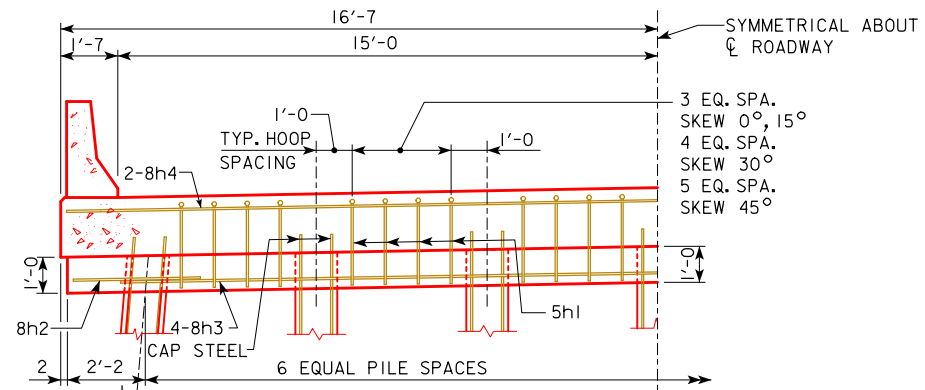

70'-0 & 80'-0 BRIDGES

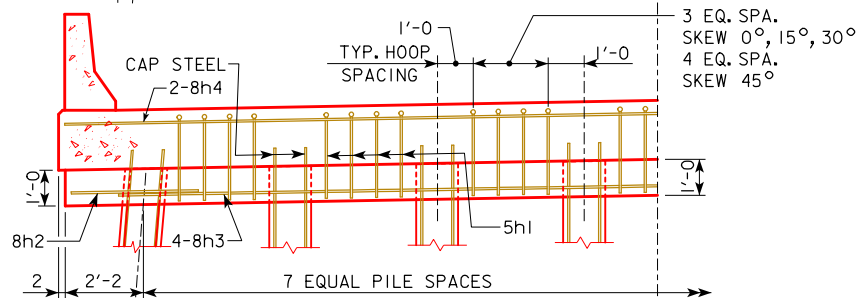

90'-0 BRIDGE

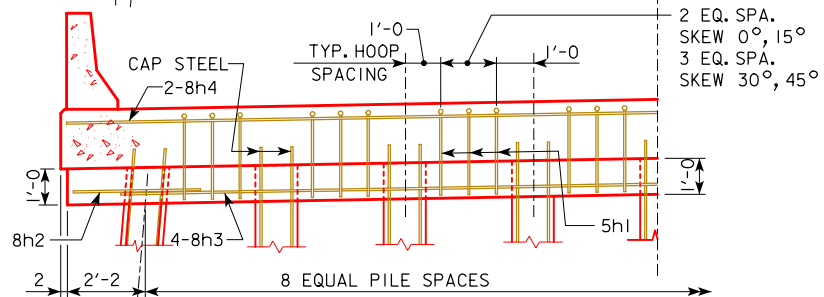

100'-0 BRIDGE

HALF SECTION NEAR PIER

SHOWING STIRRUP SPACING AND NUMBER OF PILING

NOTE: BOTTOM OF CAP ELEVATIONS WILL BE REQUIRED AT THE ϕ OF ROADWAY AND AT EACH EXTERIOR PILE.

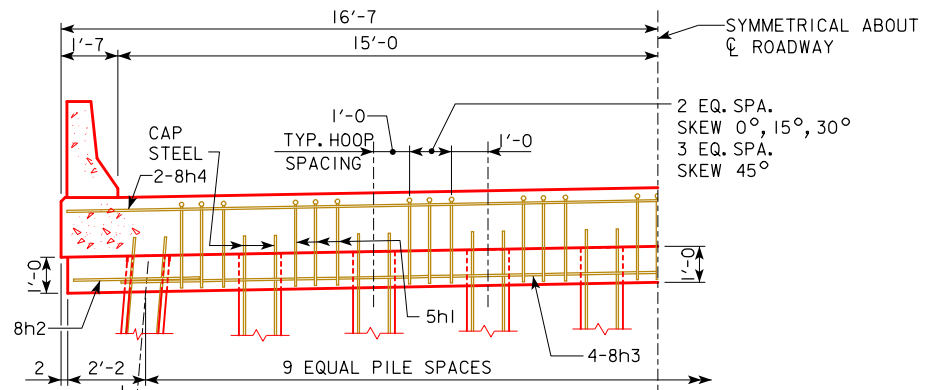

110'-0 BRIDGE

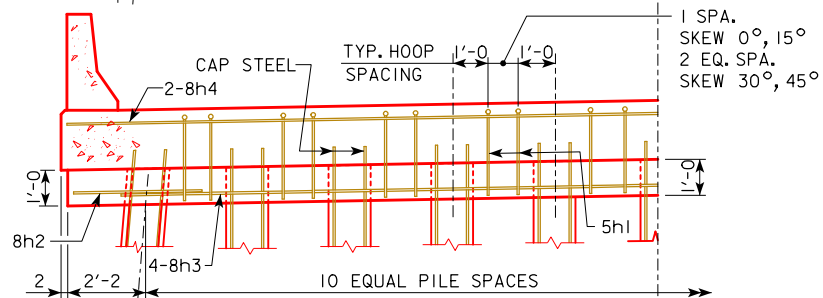

120'-0 BRIDGE

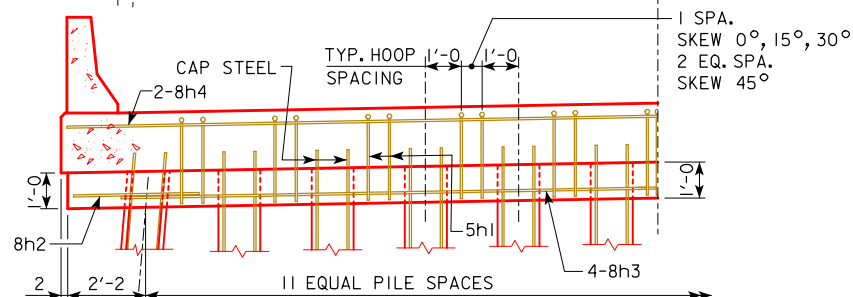

130'-0, 140'-0 & 150'-0 BRIDGES

HALF SECTION NEAR PIER

SHOWING STIRRUP SPACING AND NUMBER OF PILING

NOTE: BOTTOM OF CAP ELEVATIONS WILL BE REQUIRED AT THE ϕ OF ROADWAY AND AT EACH EXTERIOR PILE.

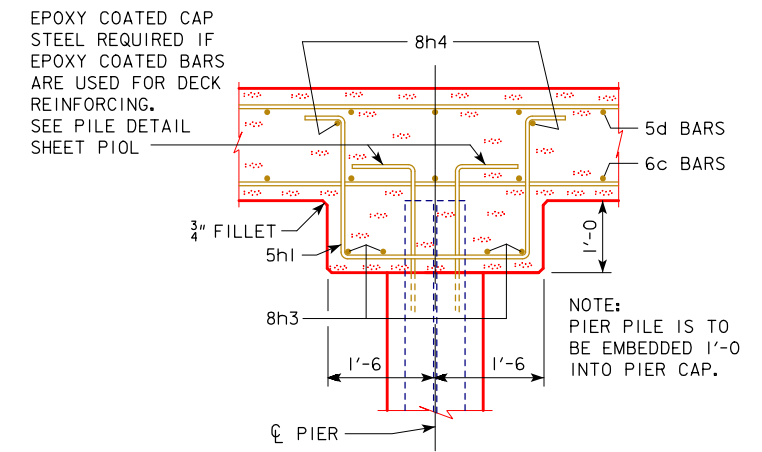

TYPICAL CAP SECTION

09-2020 LATEST REVISION DATE APPROVED BY BRIDGE ENGINEER		
	STANDARD DESIGN - 30' ROADWAY, 3 SPAN BRIDGES CONTINUOUS CONCRETE SLAB BRIDGES NOVEMBER, 2006	
	MONOLITHIC PIER CAP DETAILS ALL BRIDGES	J30-24-06

SHEET 2 OF 2

REVISED 08-2014: THE BRIDGE LENGTHS FOR THE TYP. HALF ELEVATION PIER CAP WERE CHANGED TO SHOW THE CORRECT HALF SECTION FOR THE CORRECT LENGTH.
REVISED 09-2020: UPDATED BRIDGE ENGINEER SIGNATURE.

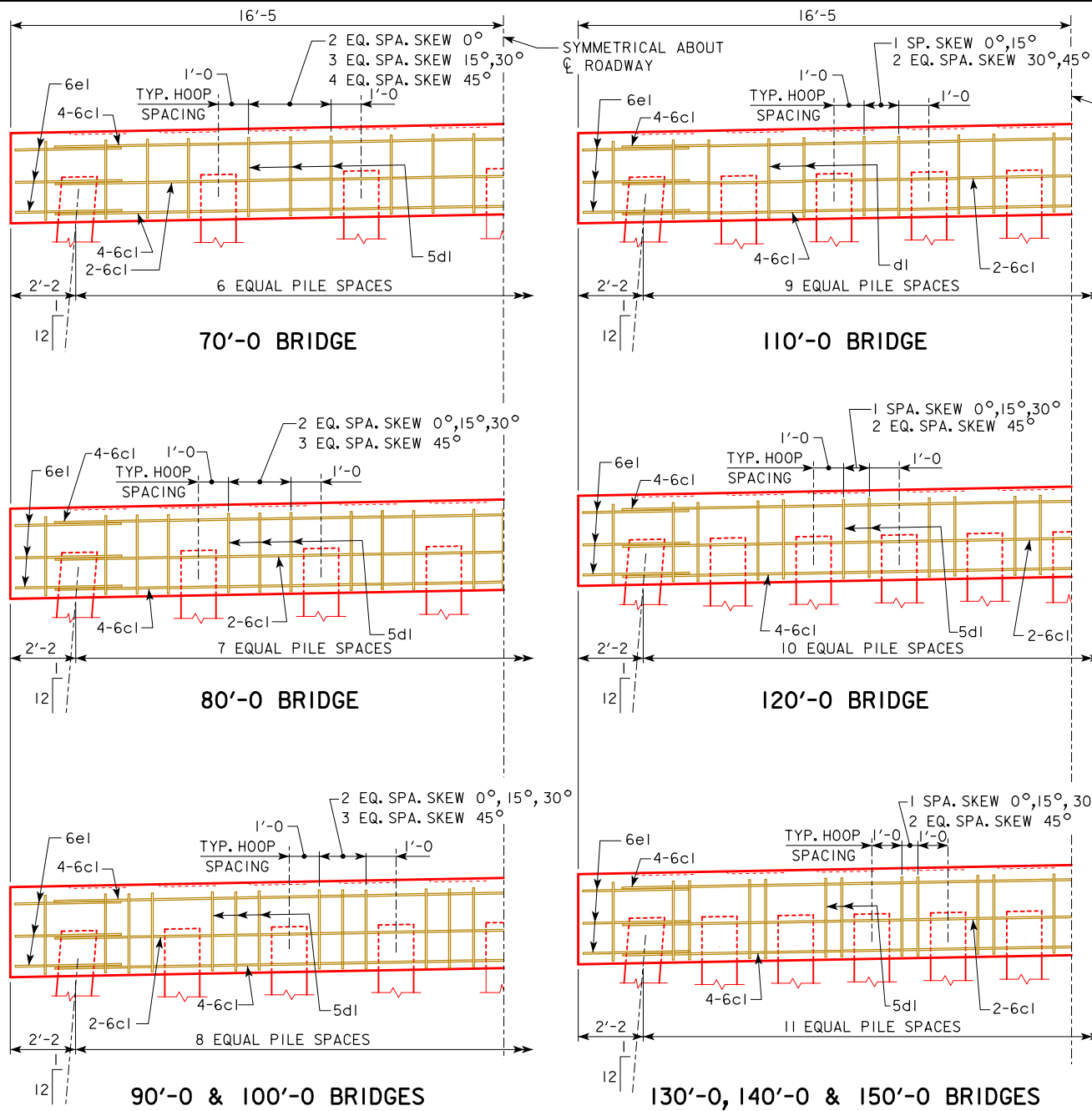

TYP. HALF ELEVATION PIER CAP
(LOOKING PARALLEL TO ϕ ROADWAY)

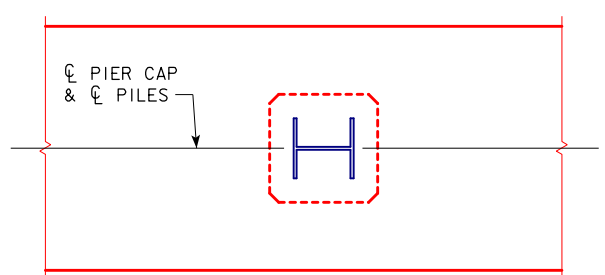

PILE ORIENTATION DETAIL FOR TYPE 3 TRESTLE BENT PILES

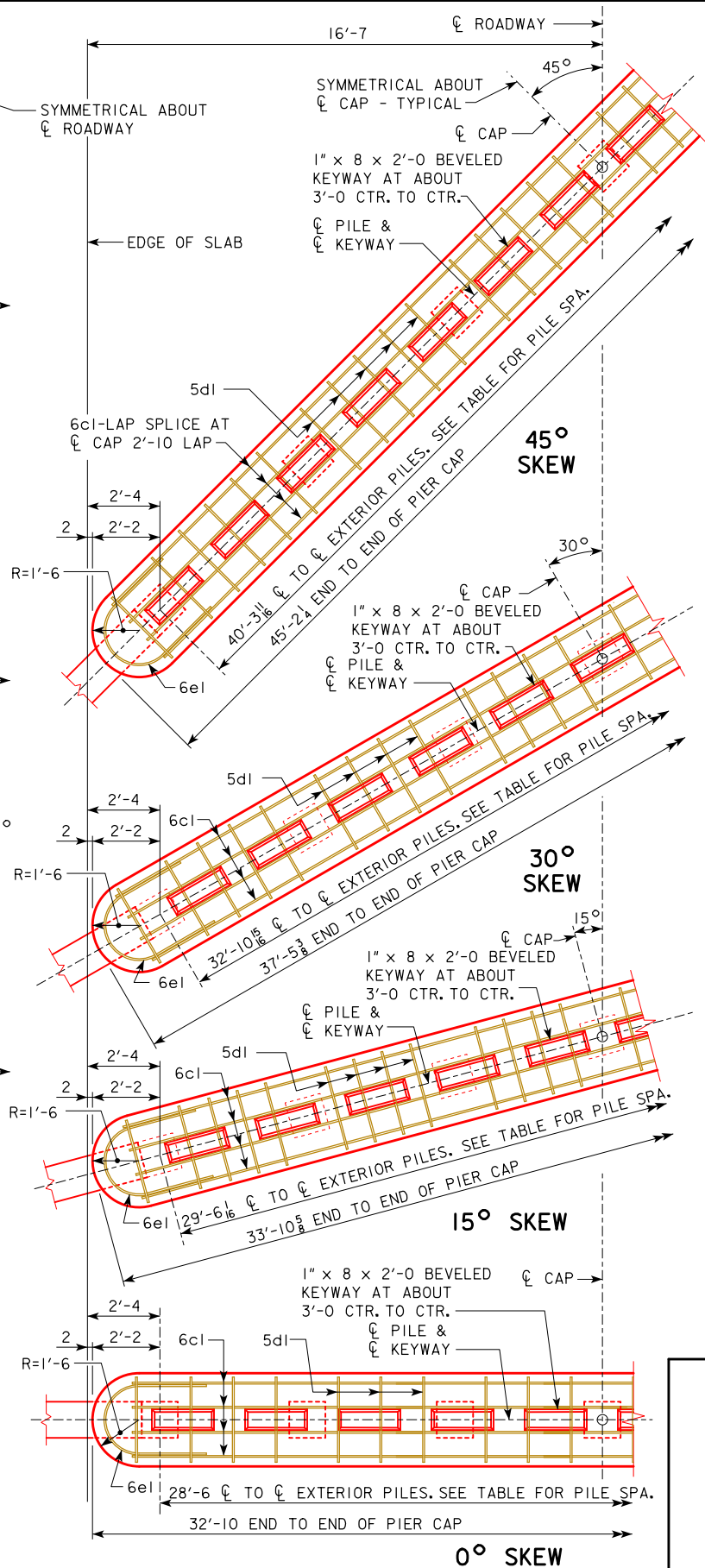

TYP. HALF PLAN VIEW

NOTE: NUMBER OF PILES AND STIRRUPS SHOWN ARE FOR A 70'-0 BRIDGE. CAP DIMENSIONS ARE TYPICAL FOR ALL BRIDGES.

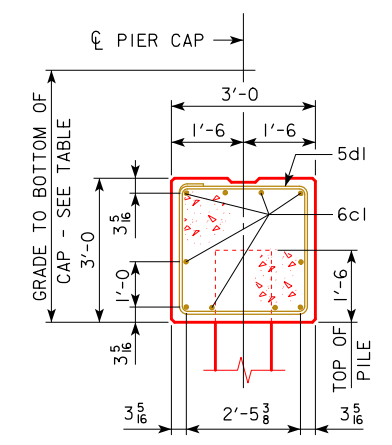

TYP. SECTION

GRADE TO BOTTOM OF CAP DIMENSION	
70'-0 BRIDGE	4'-8
80'-0 BRIDGE	4'-8 3/4
90'-0 BRIDGE	4'-9 3/4
100'-0 BRIDGE	4'-11
110'-0 BRIDGE	5'-0
120'-0 BRIDGE	5'-1 1/2
130'-0 BRIDGE	5'-2 3/4
140'-0 BRIDGE	5'-4
150'-0 BRIDGE	5'-5 1/2

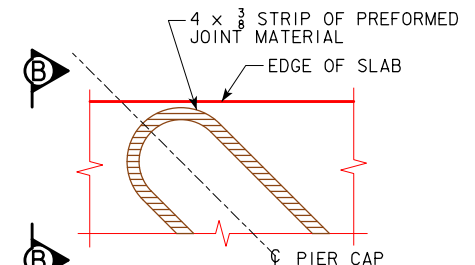

PART PLAN

SHOWING TREATMENT OF 4 x 3/8 STRIP OF PREFORMED JOINT MATERIAL AT ENDS OF PIER CAP. NOTE THAT JOINT MATERIAL IS TO GO ALL THE WAY AROUND PIER CAP FOR SQUARE AND SKEWED BRIDGES.

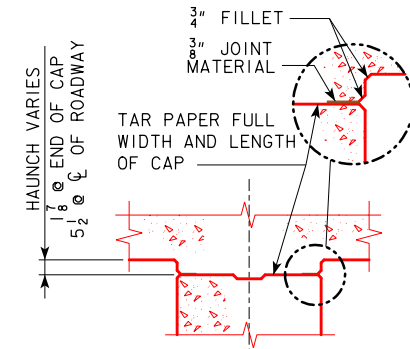

PART SECT A-A

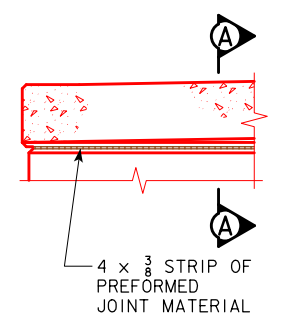

PART SECT B-B

09-2020 LATEST REVISION DATE APPROVED BY BRIDGE ENGINEER	 STANDARD DESIGN - 30' ROADWAY, 3 SPAN BRIDGES CONTINUOUS CONCRETE SLAB BRIDGES NOVEMBER, 2006	
	NON-MONOLITHIC PIER CAP DETAILS ALL BRIDGES	J30-25-06
	SHEET 1 OF 2	

BILL OF REINFORCING STEEL - ONE PIER

BRIDGE LENGTH	70'-0 BRIDGE			80'-0 BRIDGE			90'-0 BRIDGE			100'-0 BRIDGE			110'-0 BRIDGE			120'-0 BRIDGE			130'-0 BRIDGE			140'-0 BRIDGE			150'-0 BRIDGE		
MARK/SKEW/SHAPE	NO.	LENGTH	WEIGHT	NO.	LENGTH	WEIGHT	NO.	LENGTH	WEIGHT	NO.	LENGTH	WEIGHT	NO.	LENGTH	WEIGHT	NO.	LENGTH	WEIGHT	NO.	LENGTH	WEIGHT	NO.	LENGTH	WEIGHT	NO.	LENGTH	WEIGHT
6cl 0°	10	29'-10	448	10	29'-10	448	10	29'-10	448	10	29'-10	448	10	29'-10	448	10	29'-10	448	10	29'-10	448	10	29'-10	448	10	29'-10	448
15°	10	30'-11	464	10	30'-11	464	10	30'-11	464	10	30'-11	464	10	30'-11	464	10	30'-11	464	10	30'-11	464	10	30'-11	464	10	30'-11	464
30°	10	34'-6	518	10	34'-6	518	10	34'-6	518	10	34'-6	518	10	34'-6	518	10	34'-6	518	10	34'-6	518	10	34'-6	518	10	34'-6	518
45°	20	22'-6	676	20	22'-6	676	20	22'-6	676	20	22'-6	676	20	22'-6	676	20	22'-6	676	20	22'-6	676	20	22'-6	676	20	22'-6	676
5dl 0°	20	11'-8	244	23	11'-8	280	26	11'-8	317	26	11'-8	317	20	11'-8	244	22	11'-8	268	24	11'-8	292	24	11'-8	292	24	11'-8	292
15°	26	11'-8	317	23	11'-8	280	26	11'-8	317	26	11'-8	317	20	11'-8	244	22	11'-8	268	24	11'-8	292	24	11'-8	292	24	11'-8	292
30°	26	11'-8	317	23	11'-8	280	34	11'-8	414	34	11'-8	414	29	11'-8	353	22	11'-8	268	24	11'-8	292	24	11'-8	292	24	11'-8	292
45°	32	11'-8	390	30	11'-8	365	34	11'-8	414	34	11'-8	414	29	11'-8	353	32	11'-8	390	35	11'-8	426	35	11'-8	426	35	11'-8	426
6el ALL	6	9'-7	86	6	9'-7	86	6	9'-7	86	6	9'-7	86	6	9'-7	86	6	9'-7	86	6	9'-7	86	6	9'-7	86	6	9'-7	86

BENT BAR DETAILS

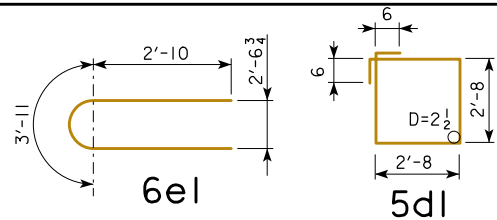

NOTE: DIMENSIONS ARE OUT TO OUT. D = PIN DIAMETER

ESTIMATED QUANTITIES - ONE PIER

BRIDGE LENGTH	SKEW	70'-0	80'-0	90'-0	100'-0	110'-0	120'-0	130'-0	140'-0	150'-0
STRUCTURAL CONCRETE (CU. YDS.)	0°	10.7	10.7	10.7	10.7	10.7	10.7	10.7	10.7	10.7
	15°	11.1	11.1	11.1	11.1	11.1	11.1	11.1	11.1	11.1
	30°	12.3	12.3	12.3	12.3	12.3	12.3	12.3	12.3	12.3
	45°	14.8	14.8	14.8	14.8	14.8	14.8	14.8	14.8	14.8
REINFORCING STEEL (LBS.)	0°	778	814	851	851	778	802	826	826	826
	15°	867	830	867	867	794	818	842	842	842
	30°	921	884	1018	1018	957	872	896	896	896
PILING (NO.)	ALL	7	8	9	9	10	11	12	12	12

TYPICAL NUMBERS OF PILES AND SPACINGS AND FACTORED PIER LOADS

BRIDGE LENGTH	70'-0	80'-0	90'-0	100'-0	110'-0	120'-0	130'-0	140'-0	150'-0
① TYP. NO. OF PILES	7	8	9	9	10	11	12	12	12
TYP. PILE SPACES @ 0°	6 SPA. @ 4'-9	7 SPA. @ ABOUT 4'-1(-)	8 SPA. @ ABOUT 3'-7(-)	8 SPA. @ ABOUT 3'-7(-)	② 9 SPA. @ 3'-2	③ 10 SPA. @ ABOUT 2'-10(+)	③ 11 SPA. @ ABOUT 2'-7(+)	③ 11 SPA. @ ABOUT 2'-7(+)	③ 11 SPA. @ ABOUT 2'-7(+)
TYP. PILE SPACES @ 15°	6 SPA. @ ABOUT 4'-11(+)	7 SPA. @ ABOUT 4'-3(-)	8 SPA. @ ABOUT 3'-8(+)	8 SPA. @ ABOUT 3'-8(+)	② 9 SPA. @ ABOUT 3'-3(+)	② 10 SPA. @ ABOUT 2'-11(+)	③ 11 SPA. @ ABOUT 2'-8(+)	③ 11 SPA. @ ABOUT 2'-8(+)	③ 11 SPA. @ ABOUT 2'-8(+)
TYP. PILE SPACES @ 30°	6 SPA. @ ABOUT 5'-6(-)	7 SPA. @ ABOUT 4'-8(+)	8 SPA. @ ABOUT 4'-1(+)	8 SPA. @ ABOUT 4'-1(+)	9 SPA. @ ABOUT 3'-8(-)	② 10 SPA. @ ABOUT 3'-3(+)	② 11 SPA. @ ABOUT 3'-0(-)	② 11 SPA. @ ABOUT 3'-0(-)	② 11 SPA. @ ABOUT 3'-0(-)
TYP. PILE SPACES @ 45°	6 SPA. @ ABOUT 6'-9(-)	7 SPA. @ ABOUT 5'-9(+)	8 SPA. @ ABOUT 5'-0(+)	8 SPA. @ ABOUT 5'-0(+)	9 SPA. @ ABOUT 4'-6(-)	10 SPA. @ ABOUT 4'-0(+)	11 SPA. @ ABOUT 3'-8(-)	11 SPA. @ ABOUT 3'-8(-)	11 SPA. @ ABOUT 3'-8(-)
④ PU, STRENGTH I DESIGN LOAD FOR PIER (KIPS)	688 KIPS	757 KIPS	834 KIPS	918 KIPS	1000 KIPS	1097 KIPS	1192 KIPS	1292 KIPS	1404 KIPS

- ① THIS TYPICAL NUMBER OF PILES MAY NEED TO BE MODIFIED DEPENDING ON SELECTED PILE TYPE AND SIZE, HEIGHT, AND RESISTANCE. IF THE NUMBER OF PILES IS DIFFERENT THAN IN THE TABLE FOR THE BRIDGE LENGTH, THE NUMBER OF 5dl BARS AND OTHER QUANTITIES NEED TO BE CHECKED AND ADJUSTED AS NEEDED. PILES 10 INCHES AND 12 INCHES IN SIZE MUST BE SPACED 2'-6 OR MORE, PILES 14 INCHES IN SIZE MUST BE SPACED 2'-11 OR MORE, AND PILES 16 INCHES IN SIZE MUST BE SPACED 3'-4 OR MORE.
- ② MAXIMUM PILE SIZE AT THIS SPACING IS 14 INCHES.
- ③ MAXIMUM PILE SIZE AT THIS SPACING IS 12 INCHES.
- ④ STRENGTH I PIER DESIGN LOAD INCLUDES DYNAMIC LOAD ALLOWANCE (IM), AND PIER CAP WEIGHT IS BASED ON 45° SKEW. USE THIS PU FOR DETERMINING NUMBER OF PILES AND PILE LENGTH.

PIER NOTES:

FOR SKEWED BRIDGES BOTTOM OF PIER CAP IS TO BE SLOPED TO COMPENSATE FOR GRADE. THEREFORE BOTTOM OF CAP ELEVATIONS WILL BE REQUIRED AT THE C OF ROADWAY AND AT EACH EXTERIOR PILE.

THE MINIMUM CLEAR DISTANCE FROM THE FACE OF THE CONCRETE TO NEAR REINFORCING BAR IS TO BE 2 INCHES UNLESS OTHERWISE NOTED OR SHOWN.

THE PIER PILES ARE TO BE DRIVEN TO FULL PENETRATION, IF PRACTICABLE, BUT IN NO CASE TO A BEARING VALUE LESS THAN THE PILE BEARING REQUIRED FOR EACH BRIDGE LENGTH AS SHOWN ON THIS SHEET. ADDITIONAL DRIVING CAPACITY MAY BE REQUIRED THROUGH SCOURABLE LAYERS. REFER TO GENERAL PLAN NOTES FOR ADDITIONAL INFORMATION.

THE CONCRETE QUANTITIES ARE BASED ON THE USE OF TYPE 3 PILING. IF TYPE 1 OR TYPE 2 IS USED, THE CONCRETE QUANTITIES MAY BE ADJUSTED TO ACCOUNT FOR THE CONCRETE DISPLACED BY THE PILING.

ALL REINFORCING STEEL IS TO BE GRADE 60.

PIER PILING WAS DESIGNED FOR HL-93 LOADING WITH AN ALLOWANCE FOR 20 LBS. PER SQ. FT. FUTURE WEARING SURFACE.

REVISED 05-2014: CHANGED THE NUMBER OF PILES AND THE PILE SPACINGS FOR THE 80' & 90' BRIDGE LENGTHS.
REVISED 09-2020: UPDATED BRIDGE ENGINEER SIGNATURE.

09-2020 LATEST REVISION DATE	 APPROVED BY BRIDGE ENGINEER	<p>STANDARD DESIGN - 30' ROADWAY, 3 SPAN BRIDGES</p> <h2 style="margin: 0;">CONTINUOUS CONCRETE SLAB BRIDGES</h2> <p>NOVEMBER, 2006</p> <p>NON-MONOLITHIC PIER CAP DETAILS ALL BRIDGES</p> <p>J30-26-06</p> <p>SHEET 2 OF 2</p>
---------------------------------	---------------------------------	---

REVISED 06-2013; REVISION FOR LRFD PILE DESIGN. REVISED 09-2020; UPDATED BRIDGE ENGINEER SIGNATURE. CHANGED PAVING BLOCK LIFTING HOOP BAR MARK, (WAS 5x1).

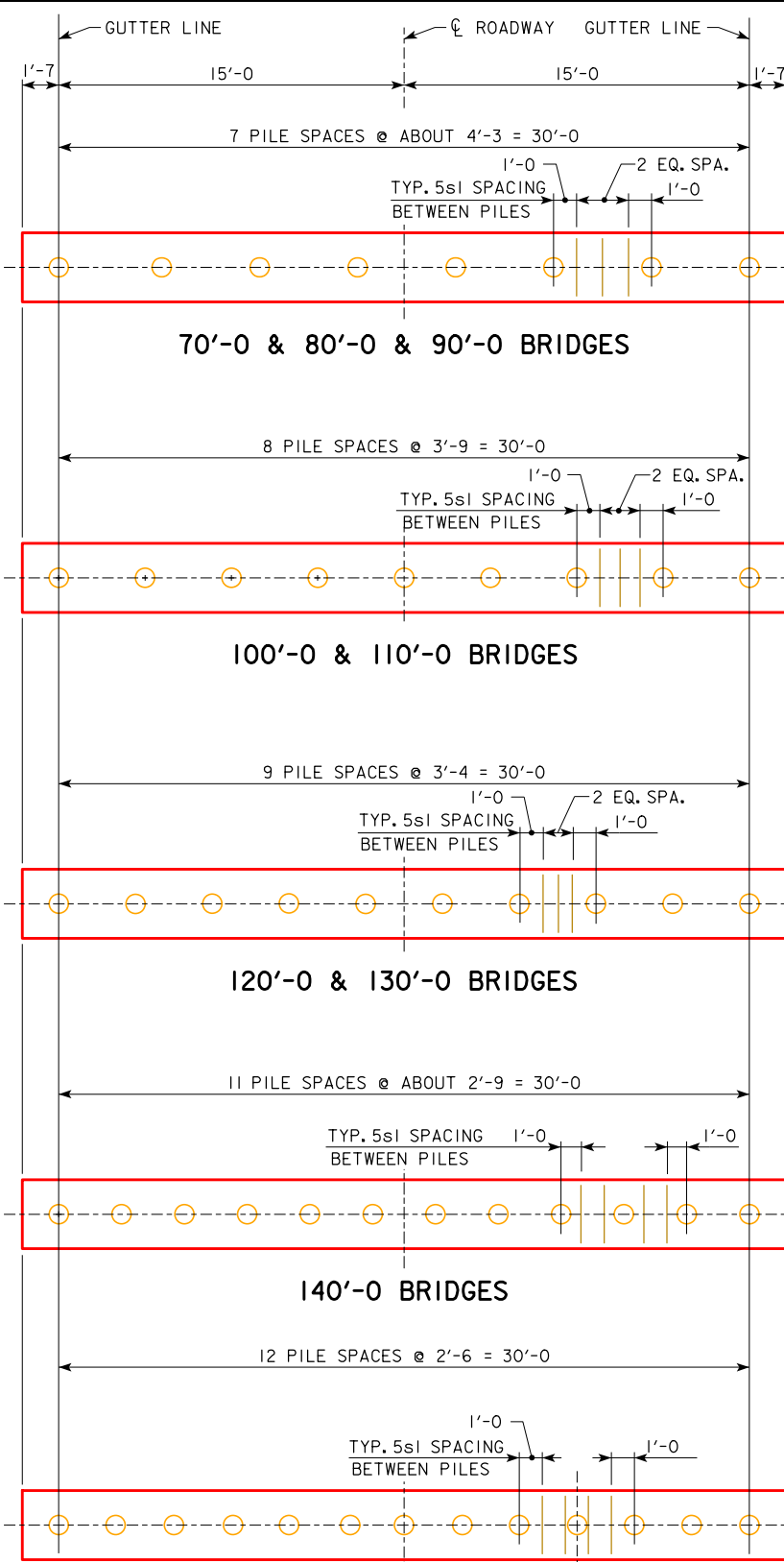

70'-0 & 80'-0 & 90'-0 BRIDGES

100'-0 & 110'-0 BRIDGES

120'-0 & 130'-0 BRIDGES

140'-0 BRIDGES

150'-0 BRIDGE

PILE PLAN - 0° SKEW WOOD PILING

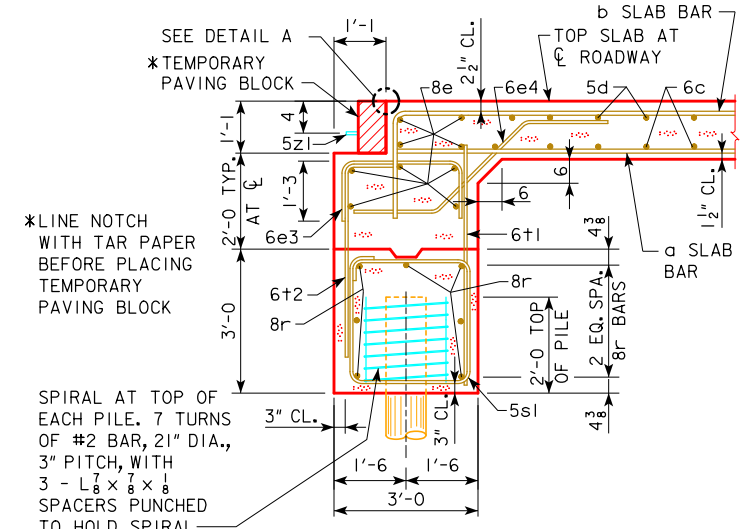

SECTION NORMAL TO ABUTMENT AT ϕ

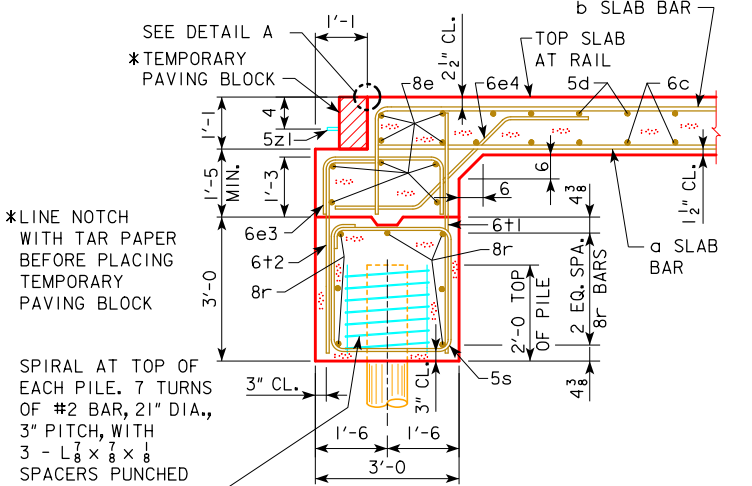

SECTION NORMAL TO ABUTMENT AT GUTTERLINE

ABUTMENT NOTES:

THE CONCRETE AND REINFORCING STEEL FOR THE WINGS IS INCLUDED WITH THE SUPERSTRUCTURE.

DETAILS ON THIS SHEET ARE TO BE USED ONLY WHEN ABUTMENTS ARE PLACED ON TIMBER PILES.

THE MINIMUM CLEAR DISTANCE FROM THE FACE OF THE CONCRETE TO NEAR REINFORCING BAR IS TO BE 2 INCHES UNLESS OTHERWISE NOTED OR SHOWN.

TIMBER PILES SHALL BE DRIVEN TO FULL PENETRATION IF PRACTICABLE BUT IN NO CASE TO A BEARING VALUE LESS THAN SHOWN IN DESIGN PLANS. TIMBER PILES SHALL NOT BE DRIVEN TO MORE THAN 160 TONS.

ALL REINFORCING STEEL IS TO BE GRADE 60.

ABUTMENT PILING WAS DESIGNED FOR HL-93 LOADING WITH AN ALLOWANCE FOR 20 LBS. PER SQ. FT. FUTURE WEARING SURFACE.

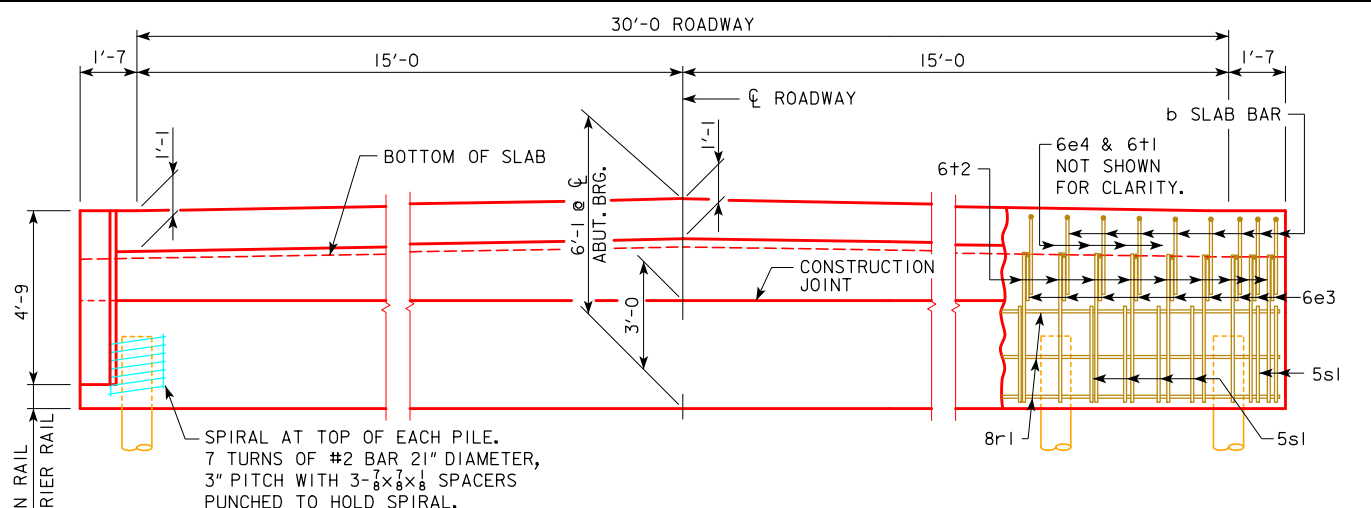

REAR ELEVATION

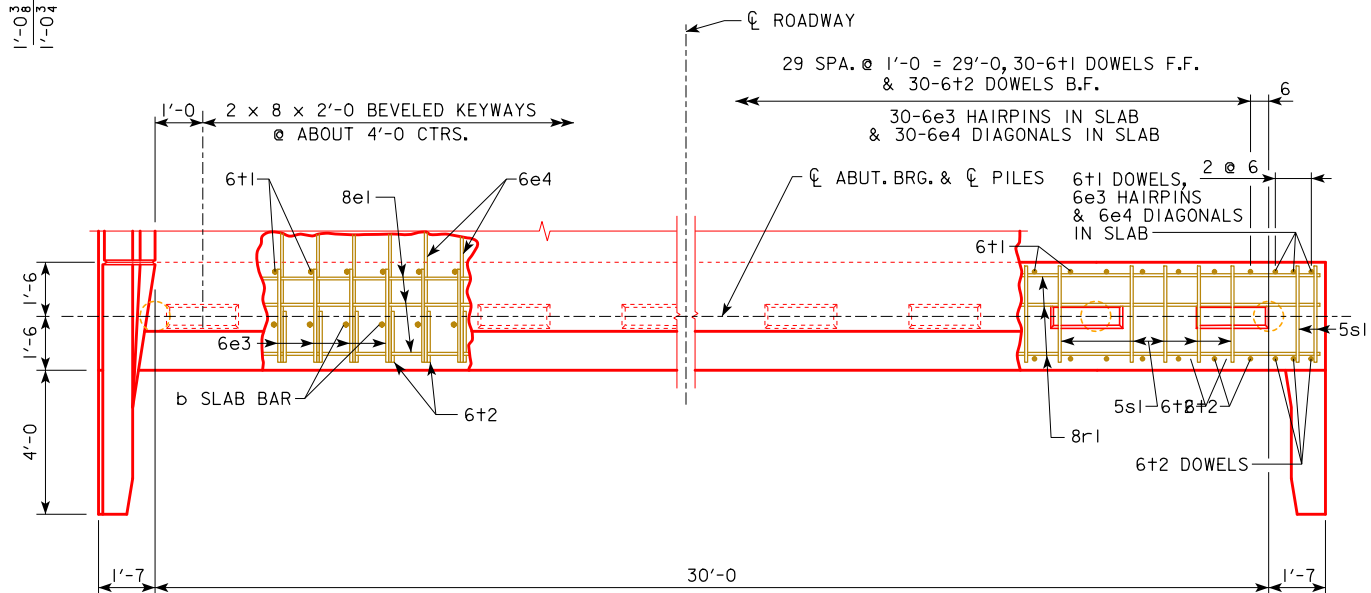

PLAN VIEW

NOTE: WING REINFORCING AND RAIL NOT SHOWN.

6e3, 6e4, AND 8e1 ARE INCLUDED WITH SUPERSTRUCTURE QUANTITIES.

NUMBER OF PILES AND ABUTMENT DESIGN LOADS									
BRIDGE LENGTH	70'-0	80'-0	90'-0	100'-0	110'-0	120'-0	130'-0	140'-0	150'-0
PILING - NUMBER	8	8	8	9	9	10	10	12	13
PU, STRENGTH I DESIGN LOAD - KIPS	377	402	426	456	485	519	551	Δ 646	Δ 684

Δ INCLUDES DYNAMIC LOAD ALLOWANCE
NOTE: PU, STRENGTH I DESIGN LOAD (KIPS) IS NOT THE VALUE USED IN THE FIELD FOR DRIVING PILES.

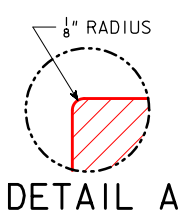

DETAIL A

09-2020 LATEST REVISION DATE APPROVED BY BRIDGE ENGINEER	 STANDARD DESIGN - 30' ROADWAY, 3 SPAN BRIDGES CONTINUOUS CONCRETE SLAB BRIDGES NOVEMBER, 2006	
	0° ABUTMENT DETAILS 0° SKEW - TIMBER PILING	J30-27-06

REVISED 06-2013: REVISION FOR LRFD PILE DESIGN.
REVISED 09-2020: UPDATED BRIDGE ENGINEER SIGNATURE. CHANGED PAVING BLOCK LIFTING HOOP BAR MARK, (WAS 5x1).

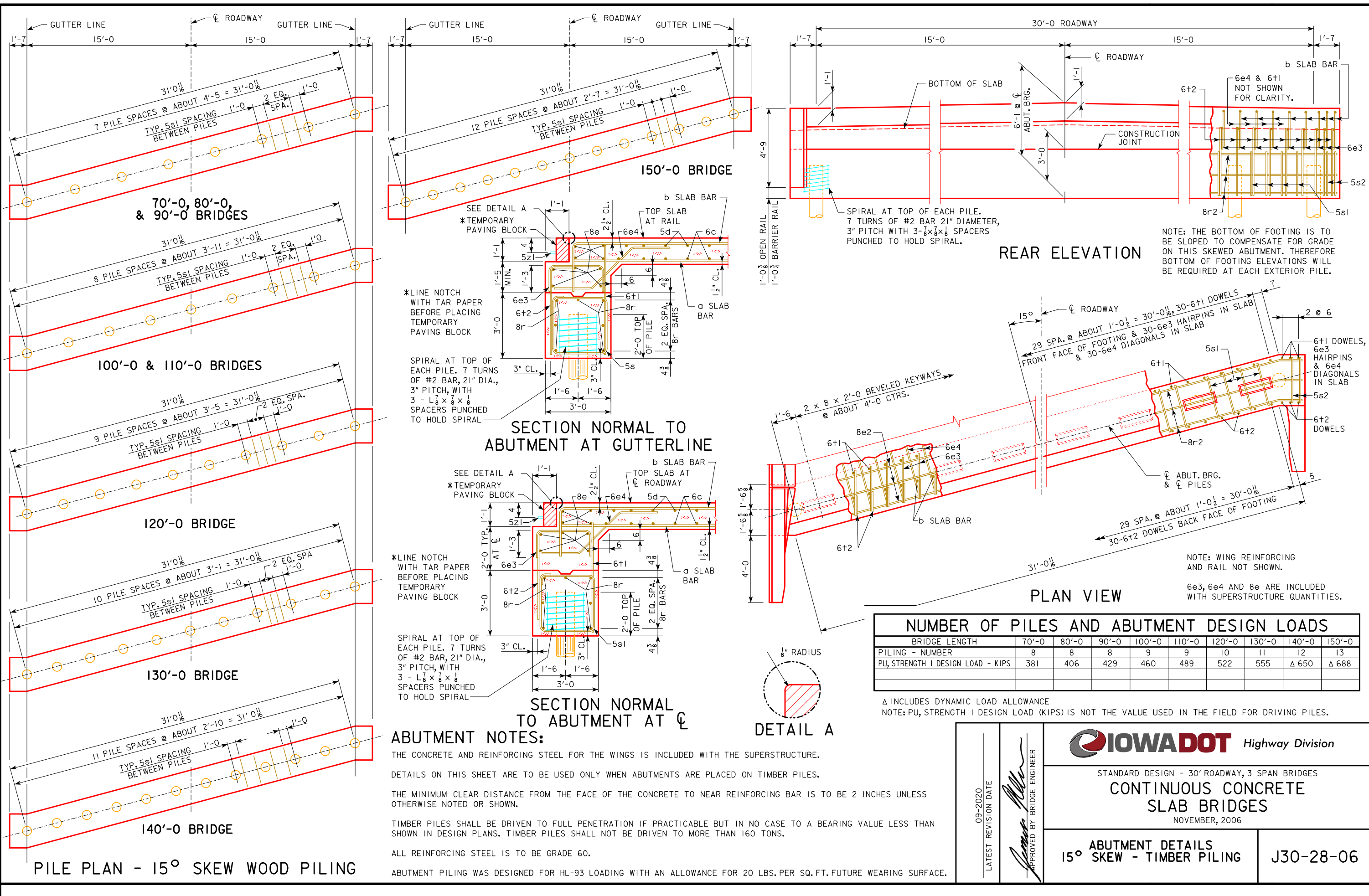

PILE PLAN - 15° SKEW WOOD PILING

REAR ELEVATION

PLAN VIEW

SECTION NORMAL TO ABUTMENT AT GUTTERLINE

SECTION NORMAL TO ABUTMENT AT CL

DETAIL A

NUMBER OF PILES AND ABUTMENT DESIGN LOADS									
BRIDGE LENGTH	70'-0	80'-0	90'-0	100'-0	110'-0	120'-0	130'-0	140'-0	150'-0
PILING - NUMBER	8	8	8	9	9	10	11	12	13
PU, STRENGTH I DESIGN LOAD - KIPS	381	406	429	460	489	522	555	Δ 650	Δ 688

Δ INCLUDES DYNAMIC LOAD ALLOWANCE
NOTE: PU, STRENGTH I DESIGN LOAD (KIPS) IS NOT THE VALUE USED IN THE FIELD FOR DRIVING PILES.

ABUTMENT NOTES:

- THE CONCRETE AND REINFORCING STEEL FOR THE WINGS IS INCLUDED WITH THE SUPERSTRUCTURE.
- DETAILS ON THIS SHEET ARE TO BE USED ONLY WHEN ABUTMENTS ARE PLACED ON TIMBER PILES.
- THE MINIMUM CLEAR DISTANCE FROM THE FACE OF THE CONCRETE TO NEAR REINFORCING BAR IS TO BE 2 INCHES UNLESS OTHERWISE NOTED OR SHOWN.
- TIMBER PILES SHALL BE DRIVEN TO FULL PENETRATION IF PRACTICABLE BUT IN NO CASE TO A BEARING VALUE LESS THAN SHOWN IN DESIGN PLANS. TIMBER PILES SHALL NOT BE DRIVEN TO MORE THAN 160 TONS.
- ALL REINFORCING STEEL IS TO BE GRADE 60.
- ABUTMENT PILING WAS DESIGNED FOR HL-93 LOADING WITH AN ALLOWANCE FOR 20 LBS. PER SQ. FT. FUTURE WEARING SURFACE.

09-2020
LATEST REVISION DATE

IOWADOT Highway Division

STANDARD DESIGN - 30' ROADWAY, 3 SPAN BRIDGES

CONTINUOUS CONCRETE SLAB BRIDGES

NOVEMBER, 2006

APPROVED BY BRIDGE ENGINEER

ABUTMENT DETAILS
15° SKEW - TIMBER PILING

J30-28-06

REVISED 06-2013; REVISION FOR LRFD PILE DESIGN.
REVISED 09-2020; UPDATED BRIDGE ENGINEER SIGNATURE. CHANGED PAVING BLOCK LIFTING HOOP BAR MARK, (WAS 5x1).

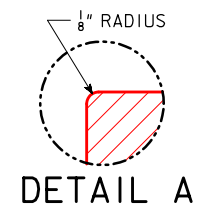
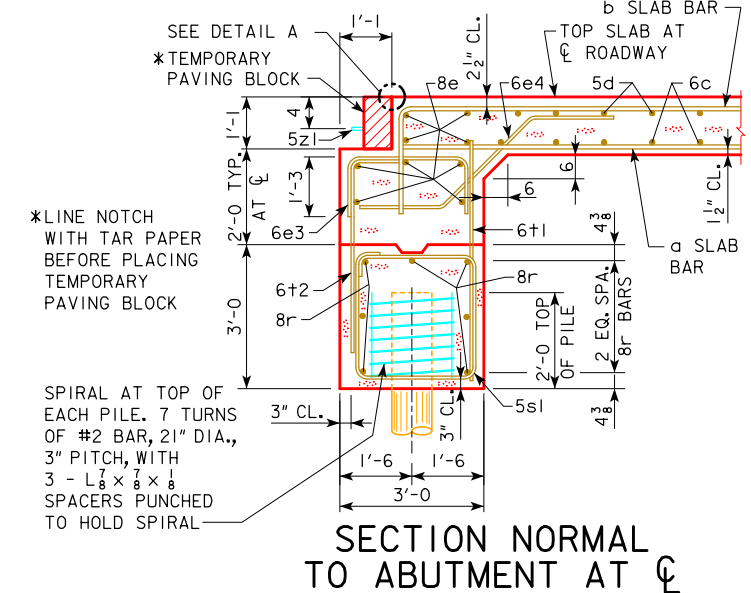
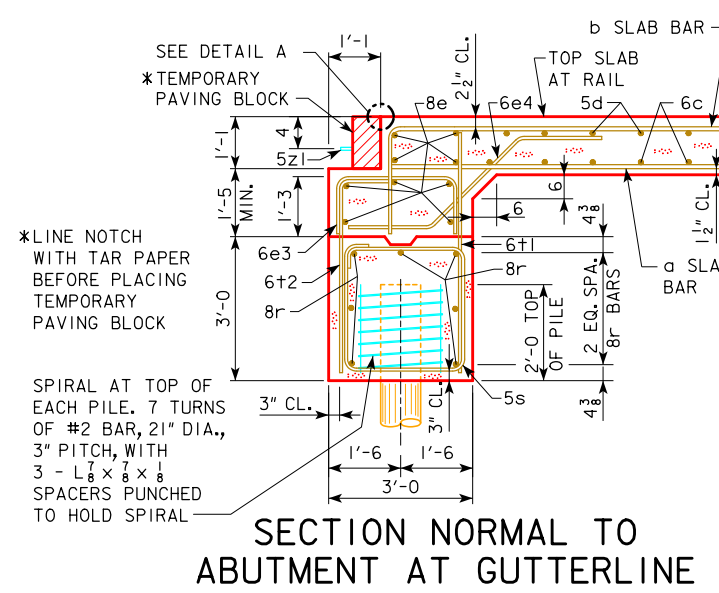
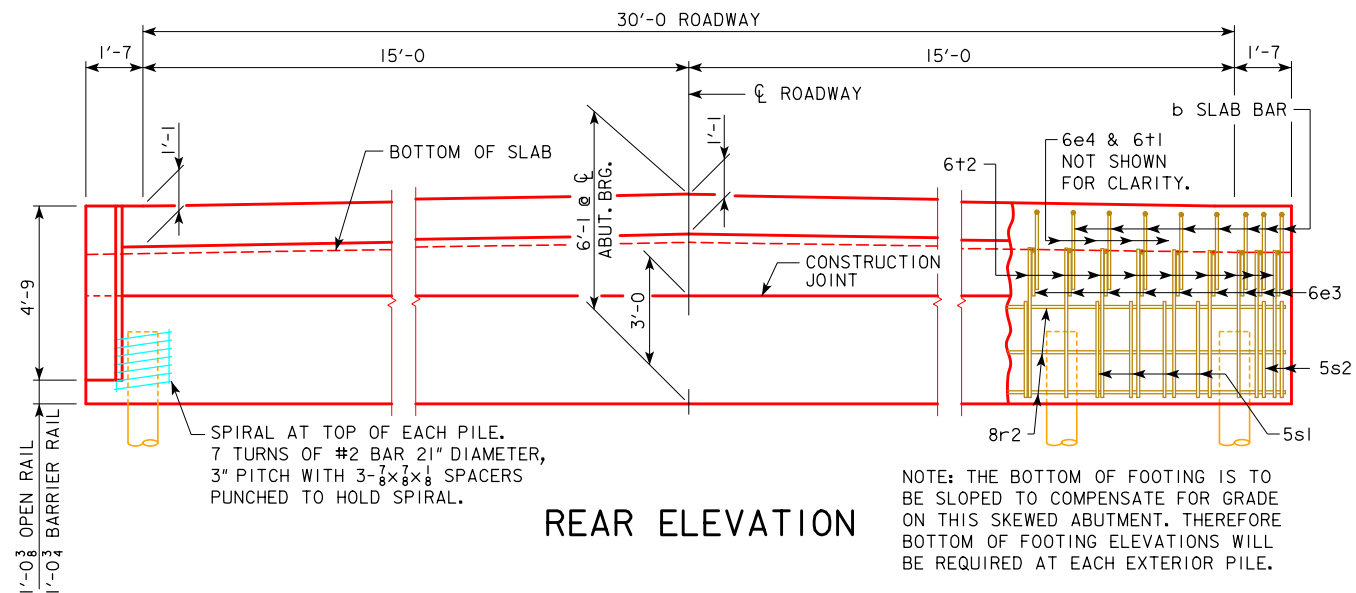

ABUTMENT NOTES:

THE CONCRETE AND REINFORCING STEEL FOR THE WINGS IS INCLUDED WITH THE SUPERSTRUCTURE.

DETAILS ON THIS SHEET ARE TO BE USED ONLY WHEN ABUTMENTS ARE PLACED ON TIMBER PILES.

THE MINIMUM CLEAR DISTANCE FROM THE FACE OF THE CONCRETE TO NEAR REINFORCING BAR IS TO BE 2 INCHES UNLESS OTHERWISE NOTED OR SHOWN.

TIMBER PILES SHALL BE DRIVEN TO FULL PENETRATION IF PRACTICABLE BUT IN NO CASE TO A BEARING VALUE LESS THAN SHOWN IN DESIGN PLANS. TIMBER PILES SHALL NOT BE DRIVEN TO MORE THAN 160 TONS.

ALL REINFORCING STEEL IS TO BE GRADE 60.

ABUTMENT PILING WAS DESIGNED FOR HL-93 LOADING WITH AN ALLOWANCE FOR 20 LBS. PER SQ. FT. FUTURE WEARING SURFACE.

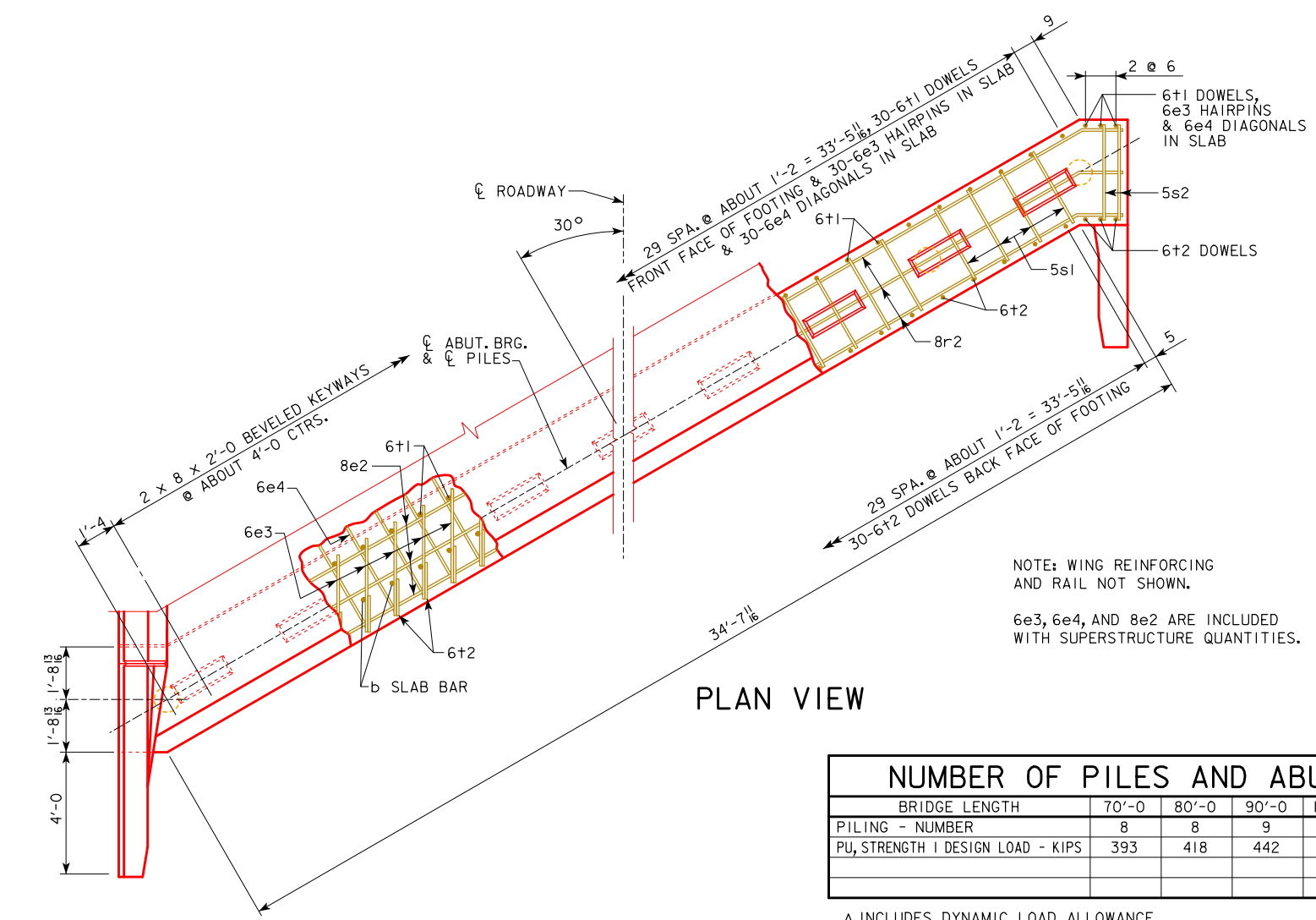

NUMBER OF PILES AND ABUTMENT DESIGN LOADS									
BRIDGE LENGTH	70'-0	80'-0	90'-0	100'-0	110'-0	120'-0	130'-0	140'-0	150'-0
PILING - NUMBER	8	8	9	9	10	10	11	12	13
PU, STRENGTH I DESIGN LOAD - KIPS	393	418	442	472	501	535	567	Δ 663	Δ 701

Δ INCLUDES DYNAMIC LOAD ALLOWANCE
NOTE: PU, STRENGTH I DESIGN LOAD (KIPS) IS NOT THE VALUE USED IN THE FIELD FOR DRIVING PILES.

09-2020 LATEST REVISION DATE APPROVED BY BRIDGE ENGINEER	 STANDARD DESIGN - 30' ROADWAY, 3 SPAN BRIDGES CONTINUOUS CONCRETE SLAB BRIDGES NOVEMBER, 2006	
	30° ABUTMENT DETAILS SKEW - TIMBER PILING	J30-29-06

REVISED 12-2008; REVISED ENTIRE SHEET.
 REVISED 09-2020; UPDATED BRIDGE ENGINEER SIGNATURE.

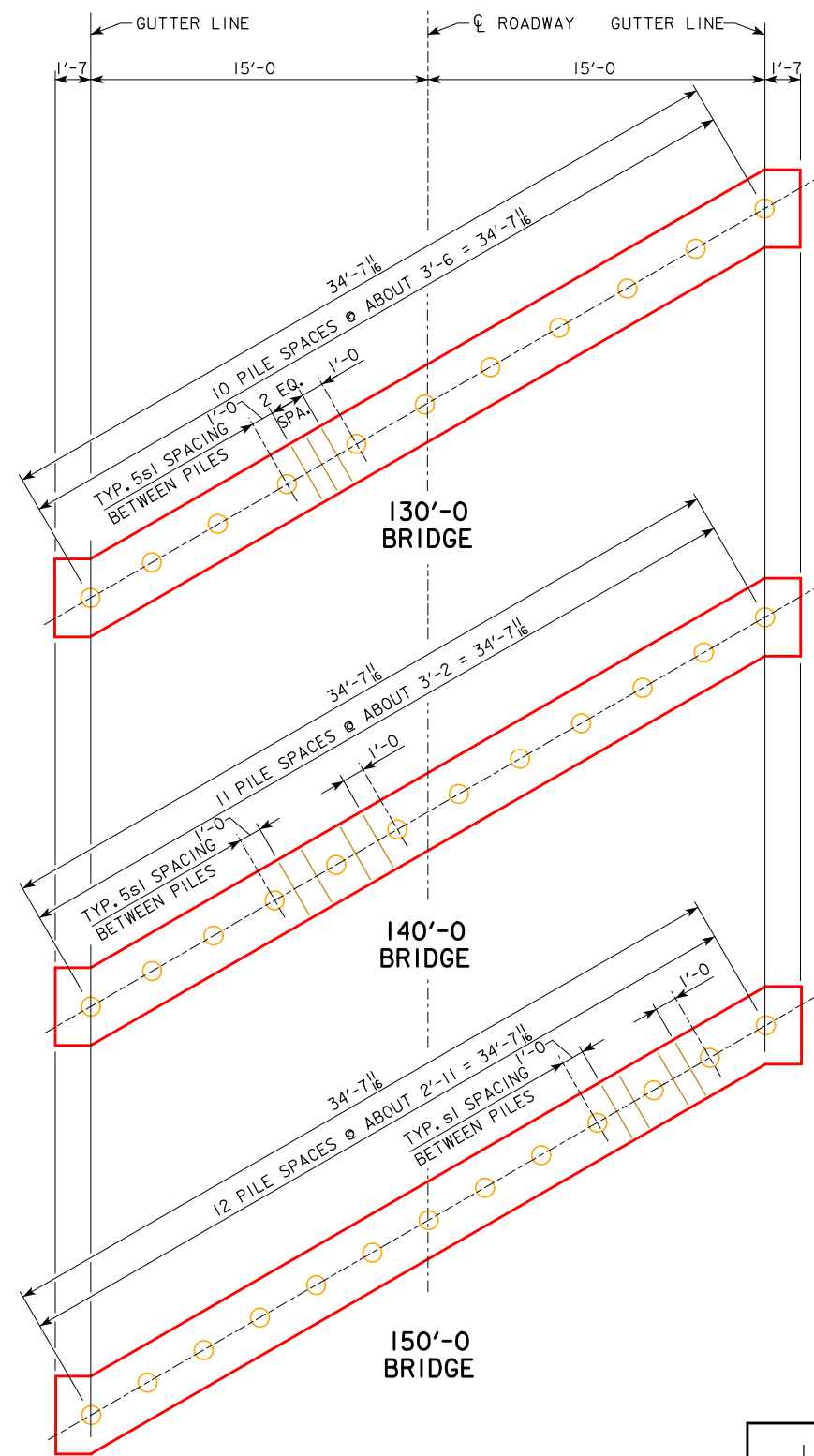
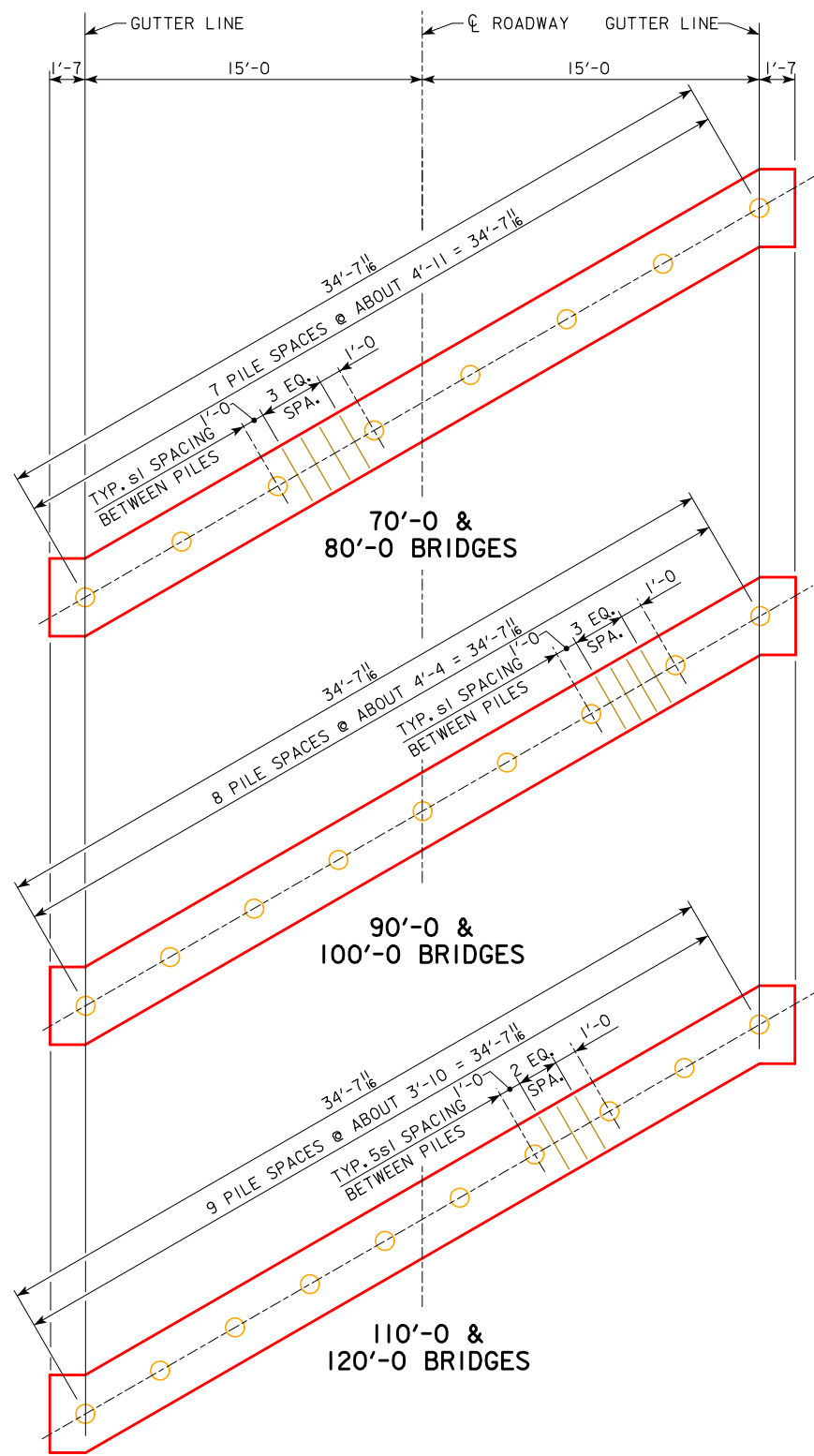

PILE PLAN - 30° SKEW
 WOOD PILING

09-2020 LATEST REVISION DATE APPROVED BY BRIDGE ENGINEER		
	STANDARD DESIGN - 30' ROADWAY, 3 SPAN BRIDGES CONTINUOUS CONCRETE SLAB BRIDGES NOVEMBER, 2006	
	ABUTMENT DETAILS 30° SKEW - TIMBER PILING	J30-30-06

REVISED 06-2013: REVISION FOR LRFD PILE DESIGN.
REVISED 09-2020: UPDATED BRIDGE ENGINEER SIGNATURE. CHANGED PAVING BLOCK LIFTING HOOP BAR MARK, (WAS 5x1).

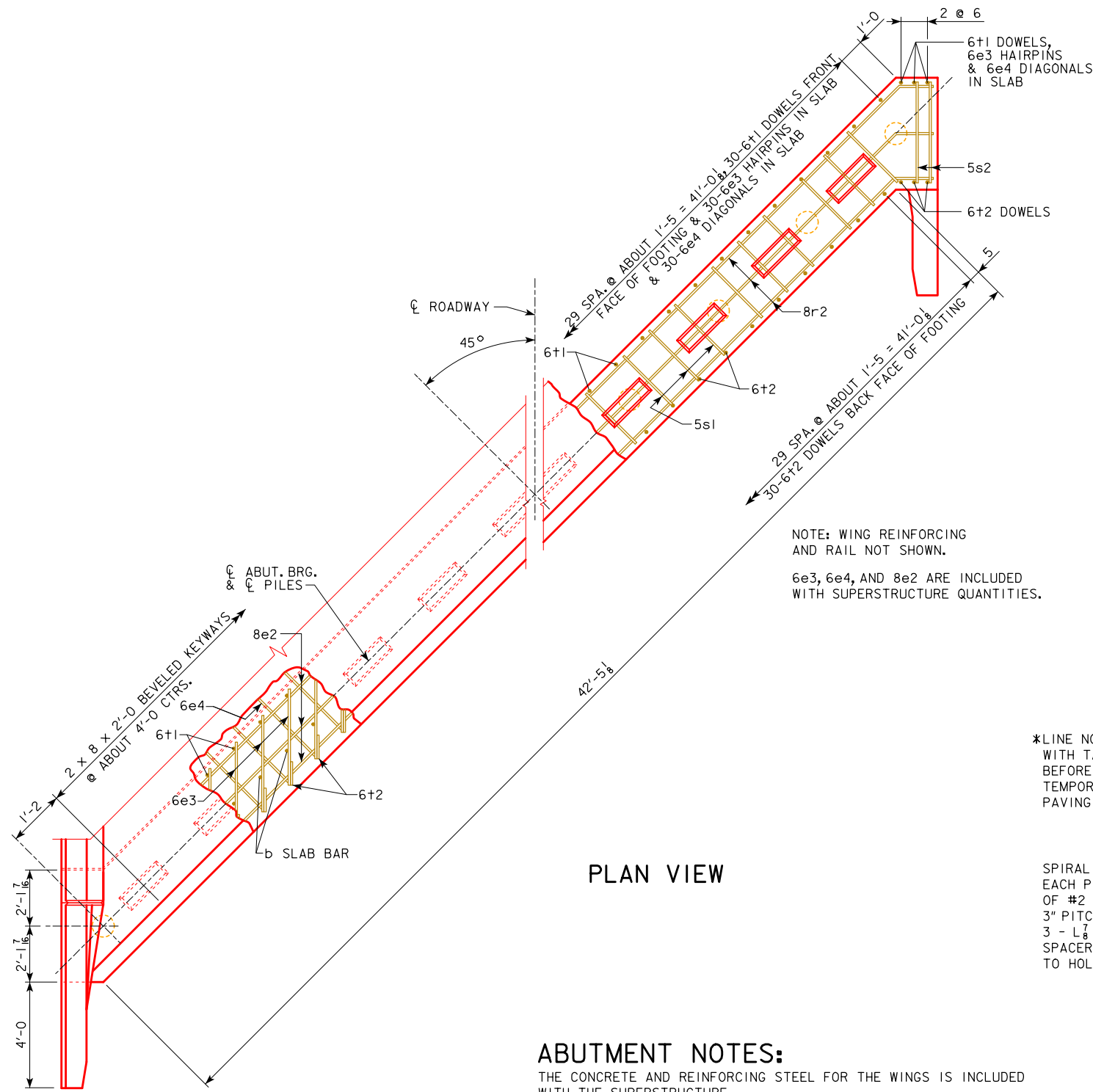

PLAN VIEW

NOTE: WING REINFORCING AND RAIL NOT SHOWN.
6e3, 6e4, AND 8e2 ARE INCLUDED WITH SUPERSTRUCTURE QUANTITIES.

ABUTMENT NOTES:

- THE CONCRETE AND REINFORCING STEEL FOR THE WINGS IS INCLUDED WITH THE SUPERSTRUCTURE.
- DETAILS ON THIS SHEET ARE TO BE USED ONLY WHEN ABUTMENTS ARE PLACED ON TIMBER PILES.
- THE MINIMUM CLEAR DISTANCE FROM THE FACE OF THE CONCRETE TO NEAR REINFORCING BAR IS TO BE 2 INCHES UNLESS OTHERWISE NOTED OR SHOWN.
- TIMBER PILES SHALL BE DRIVEN TO FULL PENETRATION IF PRACTICABLE BUT IN NO CASE TO A BEARING VALUE LESS THAN SHOWN IN DESIGN PLANS. TIMBER PILES SHALL NOT BE DRIVEN TO MORE THAN 160 TONS.
- ALL REINFORCING STEEL IS TO BE GRADE 60.
- ABUTMENT PILING WAS DESIGNED FOR HL-93 LOADING WITH AN ALLOWANCE FOR 20 LBS. PER SQ. FT. FUTURE WEARING SURFACE.

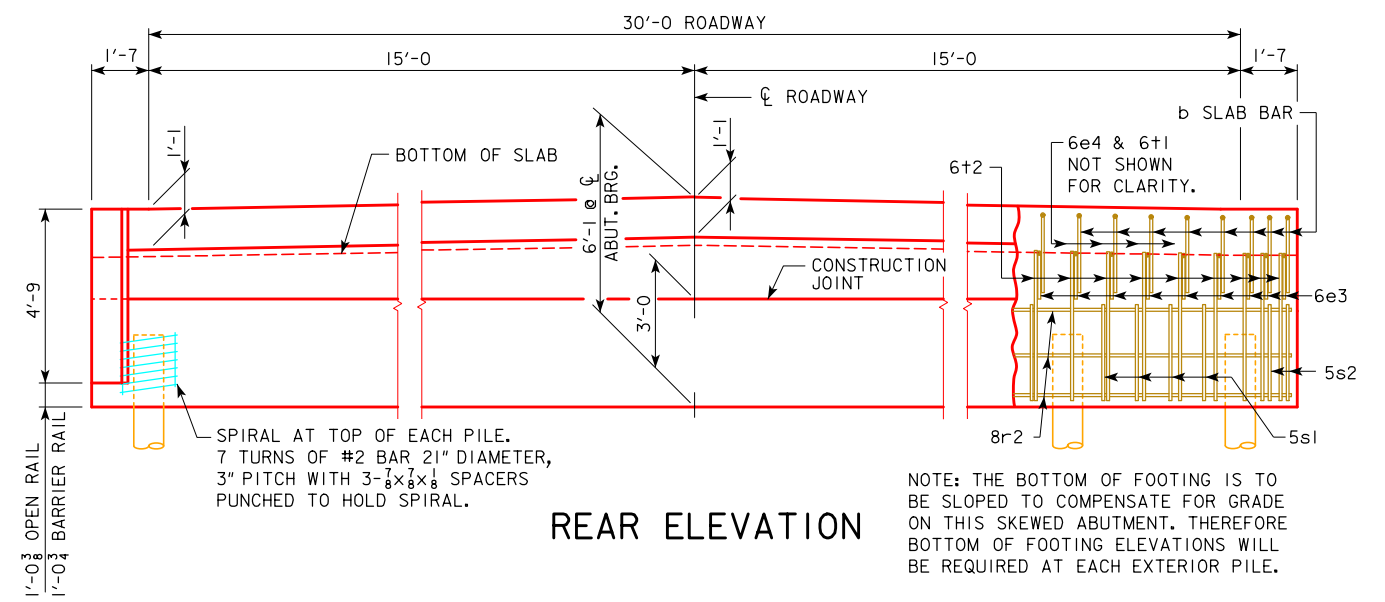

REAR ELEVATION

NOTE: THE BOTTOM OF FOOTING IS TO BE SLOPED TO COMPENSATE FOR GRADE ON THIS SKEWED ABUTMENT. THEREFORE BOTTOM OF FOOTING ELEVATIONS WILL BE REQUIRED AT EACH EXTERIOR PILE.

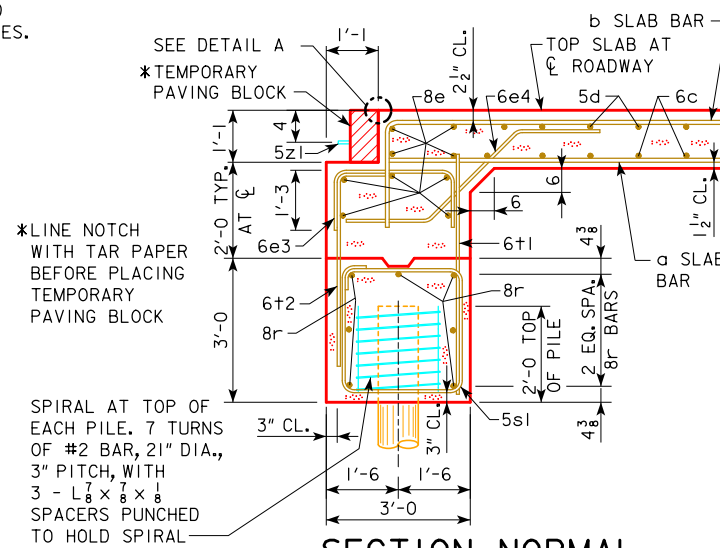

SECTION NORMAL TO ABUTMENT AT CL

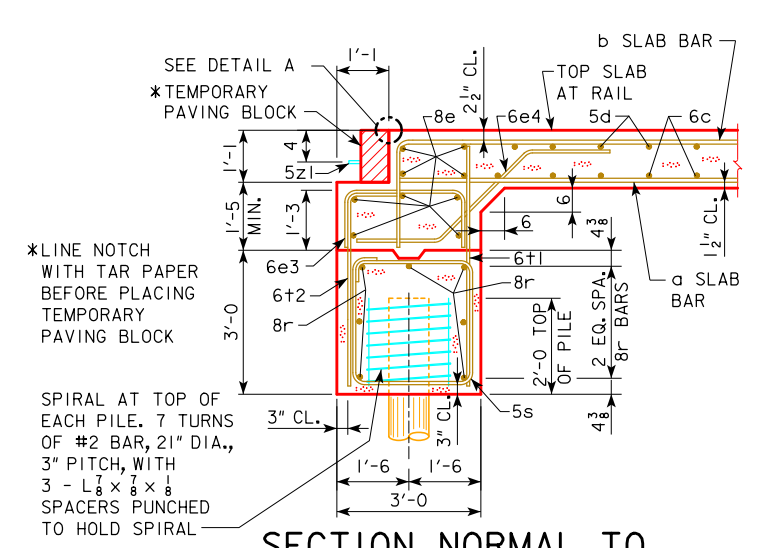

SECTION NORMAL TO ABUTMENT AT GUTTERLINE

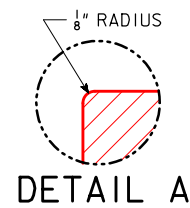

DETAIL A

<p>09-2020 LATEST REVISION DATE</p>	<p><i>James Miller</i> APPROVED BY BRIDGE ENGINEER</p>	<p>IOWADOT Highway Division</p> <p>STANDARD DESIGN - 30' ROADWAY, 3 SPAN BRIDGES</p> <p>CONTINUOUS CONCRETE SLAB BRIDGES</p> <p>NOVEMBER, 2006</p>
<p>45° ABUTMENT DETAILS 45° SKEW - TIMBER PILING</p>		<p>J30-31-06</p>

REVISED 06-2013: REVISION FOR LRFD PILE DESIGN.
 REVISED 09-2020: UPDATED BRIDGE ENGINEER SIGNATURE.

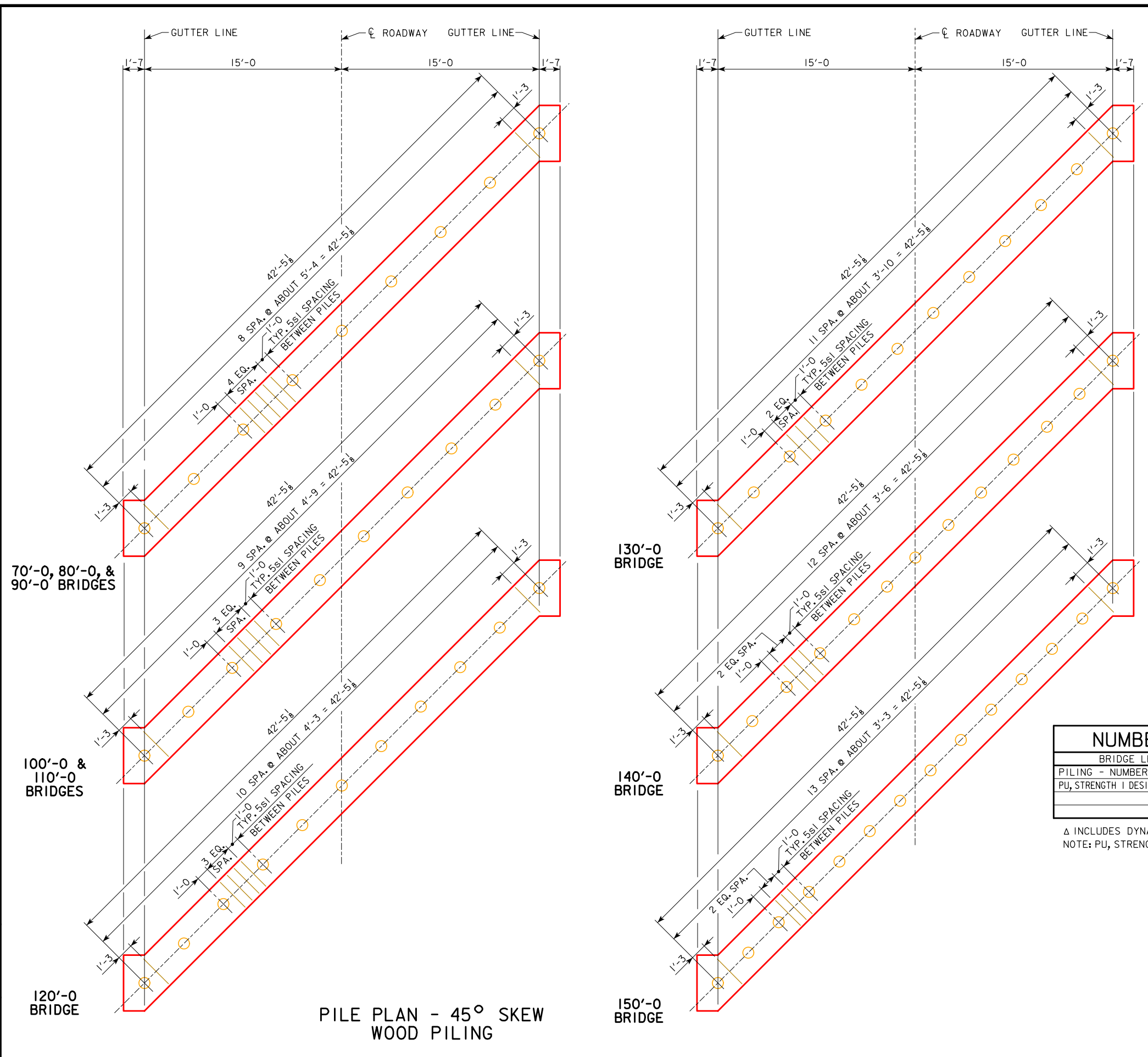

70'-0, 80'-0, & 90'-0 BRIDGES

100'-0 & 110'-0 BRIDGES

120'-0 BRIDGE

130'-0 BRIDGE

140'-0 BRIDGE

150'-0 BRIDGE

PILE PLAN - 45° SKEW
WOOD PILING

NUMBER OF PILES AND ABUTMENT DESIGN LOADS									
BRIDGE LENGTH	70'-0	80'-0	90'-0	100'-0	110'-0	120'-0	130'-0	140'-0	150'-0
PILING - NUMBER	9	9	9	10	10	11	12	13	14
PU, STRENGTH DESIGN LOAD - KIPS	419	444	468	499	528	562	595	Δ 691	Δ 729

Δ INCLUDES DYNAMIC LOAD ALLOWANCE
 NOTE: PU, STRENGTH | DESIGN LOAD (KIPS) IS NOT THE VALUE USED IN THE FIELD FOR DRIVING PILES.

09-2020 LATEST REVISION DATE APPROVED BY BRIDGE ENGINEER	 STANDARD DESIGN - 30' ROADWAY, 3 SPAN BRIDGES CONTINUOUS CONCRETE SLAB BRIDGES NOVEMBER, 2006	
	ABUTMENT DETAILS 45° SKEW - TIMBER PILING	J30-32-06

BILL OF REINFORCING STEEL - ONE ABUTMENT - 0° SKEW

BRIDGE LENGTH				70'-0	80'-0	90'-0	100'-0	110'-0	120'-0	130'-0	140'-0	150'-0	
MARK	LOCATION	SHAPE	LENGTH	NO.	WEIGHT	NO.	WEIGHT	NO.	WEIGHT	NO.	WEIGHT	NO.	WEIGHT
8r1	ABUTMENT FOOTING LONGITUDINAL		32'-10	7	614	7	614	7	614	7	614	7	614
5s1	ABUTMENT FOOTING HOOPS		11'-0	25	287	25	287	25	287	28	321	31	356
6+1	FOOTING TO SLAB DOWELS		5'-0	36	270	36	270	36	270	36	270	36	270
6+2	FOOTING TO SLAB DOWELS		5'-7	36	302	36	302	36	302	36	302	36	302
#2	PILE SPIRAL		38'-6	8	51	8	51	8	51	9	58	9	58
	SPIRAL SPACERS - L 7/8 X 7/8 X 1/8 X 0.70		1'-10	24	31	24	31	24	31	27	35	27	35
REINFORCING STEEL - TOTAL (LBS.)					1555	1555	1555	1600	1600	1645	1645	1607	1641

BILL OF REINFORCING STEEL - ONE ABUTMENT - 15° SKEW

BRIDGE LENGTH				70'-0	80'-0	90'-0	100'-0	110'-0	120'-0	130'-0	140'-0	150'-0	
MARK	LOCATION	SHAPE	LENGTH	NO.	WEIGHT	NO.	WEIGHT	NO.	WEIGHT	NO.	WEIGHT	NO.	WEIGHT
8r2	ABUTMENT FOOTING LONGITUDINAL		33'-11	7	634	7	634	7	634	7	634	7	634
5s1	ABUTMENT FOOTING HOOPS		11'-0	21	241	21	241	21	241	24	275	24	275
5s2	ABUTMENT FOOTING HOOPS		11'-3	4	47	4	47	4	47	4	47	4	47
6+1	FOOTING TO SLAB DOWELS		5'-0	36	270	36	270	36	270	36	270	36	270
6+2	FOOTING TO SLAB DOWELS		5'-7	36	302	36	302	36	302	36	302	36	302
#2	PILE SPIRAL		38'-6	8	51	8	51	8	51	9	58	9	58
	SPIRAL SPACERS - L 7/8 X 7/8 X 1/8 X 0.70		1'-10	24	31	24	31	24	31	27	35	27	35
REINFORCING STEEL - TOTAL (LBS.)					1576	1576	1576	1621	1621	1666	1710	1628	1662

BILL OF REINFORCING STEEL - ONE ABUTMENT - 30° SKEW

BRIDGE LENGTH				70'-0	80'-0	90'-0	100'-0	110'-0	120'-0	130'-0	140'-0	150'-0	
MARK	LOCATION	SHAPE	LENGTH	NO.	WEIGHT	NO.	WEIGHT	NO.	WEIGHT	NO.	WEIGHT	NO.	WEIGHT
8r2	ABUTMENT FOOTING LONGITUDINAL		37'-6	7	701	7	701	7	701	7	701	7	701
5s1	ABUTMENT FOOTING HOOPS		11'-0	28	321	28	321	32	367	32	367	27	310
5s2	ABUTMENT FOOTING HOOPS		11'-11	4	50	4	50	4	50	4	50	4	50
6+1	FOOTING TO SLAB DOWELS		5'-0	36	270	36	270	36	270	36	270	36	270
6+2	FOOTING TO SLAB DOWELS		5'-7	36	302	36	302	36	302	36	302	36	302
#2	PILE SPIRAL		38'-6	8	51	8	51	9	58	9	58	10	64
	SPIRAL SPACERS - L 7/8 X 7/8 X 1/8 X 0.70		1'-10	24	31	24	31	27	35	27	35	30	39
REINFORCING STEEL - TOTAL (LBS.)					1726	1726	1783	1783	1736	1736	1780	1698	1732

BILL OF REINFORCING STEEL - ONE ABUTMENT - 45° SKEW

BRIDGE LENGTH				70'-0	80'-0	90'-0	100'-0	110'-0	120'-0	130'-0	140'-0	150'-0	
MARK	LOCATION	SHAPE	LENGTH	NO.	WEIGHT	NO.	WEIGHT	NO.	WEIGHT	NO.	WEIGHT	NO.	WEIGHT
8r2	ABUTMENT FOOTING LONGITUDINAL		45'-3	7	846	7	846	7	846	7	846	7	846
5s1	ABUTMENT FOOTING HOOPS		11'-0	40	459	40	459	40	459	36	413	36	413
5s2	ABUTMENT FOOTING HOOPS		13'-6	4	56	4	56	4	56	4	56	4	56
6+1	FOOTING TO SLAB DOWELS		5'-0	36	270	36	270	36	270	36	270	36	270
6+2	FOOTING TO SLAB DOWELS		5'-7	36	302	36	302	36	302	36	302	36	302
#2	PILE SPIRAL		38'-6	9	58	9	58	9	58	10	64	11	71
	SPIRAL SPACERS - L 7/8 X 7/8 X 1/8 X 0.70		1'-10	27	35	27	35	27	35	30	39	30	39
REINFORCING STEEL - TOTAL (LBS.)					2026	2026	2026	1990	1990	2046	1976	2021	2065

ESTIMATED QUANTITIES - ONE ABUT. - 0° SKEW

LOCATION	UNIT	QUANTITY									
BRIDGE LENGTH		70'-0	80'-0	90'-0	100'-0	110'-0	120'-0	130'-0	140'-0	150'-0	
STRUCTURAL CONCRETE (BRIDGE)	C.Y.	11.6	11.6	11.6	11.6	11.6	11.5	11.5	11.4	11.3	
REINFORCING STEEL	LBS.	1555	1555	1555	1600	1600	1645	1645	1607	1641	
WOOD PILES (TREATED)	NO.	8	8	8	9	9	10	10	12	13	
PREBORE HOLES	FT.	-	-	-	-	-	-	-	120	130	

ESTIMATED QUANTITIES - ONE ABUT. - 15° SKEW

LOCATION	UNIT	QUANTITY									
BRIDGE LENGTH		70'-0	80'-0	90'-0	100'-0	110'-0	120'-0	130'-0	140'-0	150'-0	
STRUCTURAL CONCRETE (BRIDGE)	C.Y.	11.0	11.0	11.0	11.0	11.0	10.9	10.9	10.8	10.7	
REINFORCING STEEL	LBS.	1576	1576	1576	1621	1621	1666	1710	1628	1662	
WOOD PILES (TREATED)	NO.	8	8	8	9	9	10	11	12	13	
PREBORE HOLES	FT.	-	-	-	-	-	-	-	120	130	

ESTIMATED QUANTITIES - ONE ABUT. - 30° SKEW

LOCATION	UNIT	QUANTITY									
BRIDGE LENGTH		70'-0	80'-0	90'-0	100'-0	110'-0	120'-0	130'-0	140'-0	150'-0	
STRUCTURAL CONCRETE (BRIDGE)	C.Y.	12.3	12.3	12.2	12.2	12.2	12.2	12.2	12.1	12.0	
REINFORCING STEEL	LBS.	1726	1726	1783	1783	1736	1736	1780	1698	1732	
WOOD PILES (TREATED)	NO.	8	8	9	9	10	10	11	12	13	
PREBORE HOLES	FT.	-	-	-	-	-	-	-	120	130	

ESTIMATED QUANTITIES - ONE ABUT. - 45° SKEW

LOCATION	UNIT	QUANTITY									
BRIDGE LENGTH		70'-0	80'-0	90'-0	100'-0	110'-0	120'-0	130'-0	140'-0	150'-0	
STRUCTURAL CONCRETE (BRIDGE)	C.Y.	15.2	15.2	15.1	15.1	15.1	15.1	15.0	15.0	14.9	
REINFORCING STEEL	LBS.	2026	2026	2026	1990	1990	2046	1976	2021	2065	
WOOD PILES (TREATED)	NO.	9	9	9	10	10	11	12	13	14	
PREBORE HOLES	FT.	-	-	-	-	-	-	-	130	140	

BENT BAR DETAILS

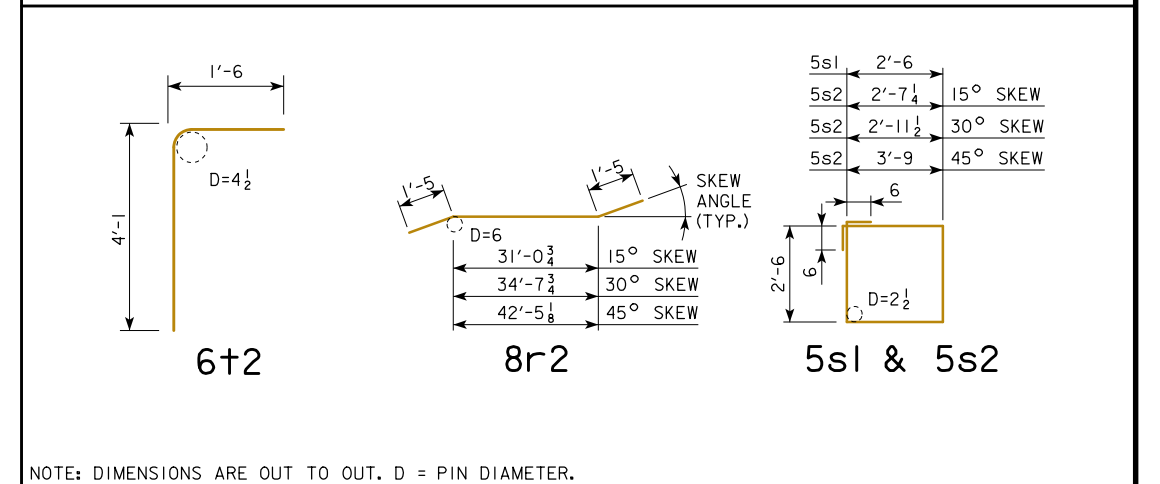

REVISED 07-2009; CONCRETE QUANTITIES CHANGED.
REVISED 09-2020; UPDATED BRIDGE ENGINEER SIGNATURE.

09-2020 LATEST REVISION DATE APPROVED BY BRIDGE ENGINEER	 STANDARD DESIGN - 30' ROADWAY, 3 SPAN BRIDGES CONTINUOUS CONCRETE SLAB BRIDGES NOVEMBER, 2006
	ABUTMENT DETAILS TIMBER PILING
	J30-33-06

REVISED 06-2013; REVISION FOR LRFD PILE DESIGN. CHANGED PAVING BLOCK LIFTING HOOP BAR MARK, (WAS 5X1).
REVISED 09-2020; UPDATED BRIDGE ENGINEER SIGNATURE.

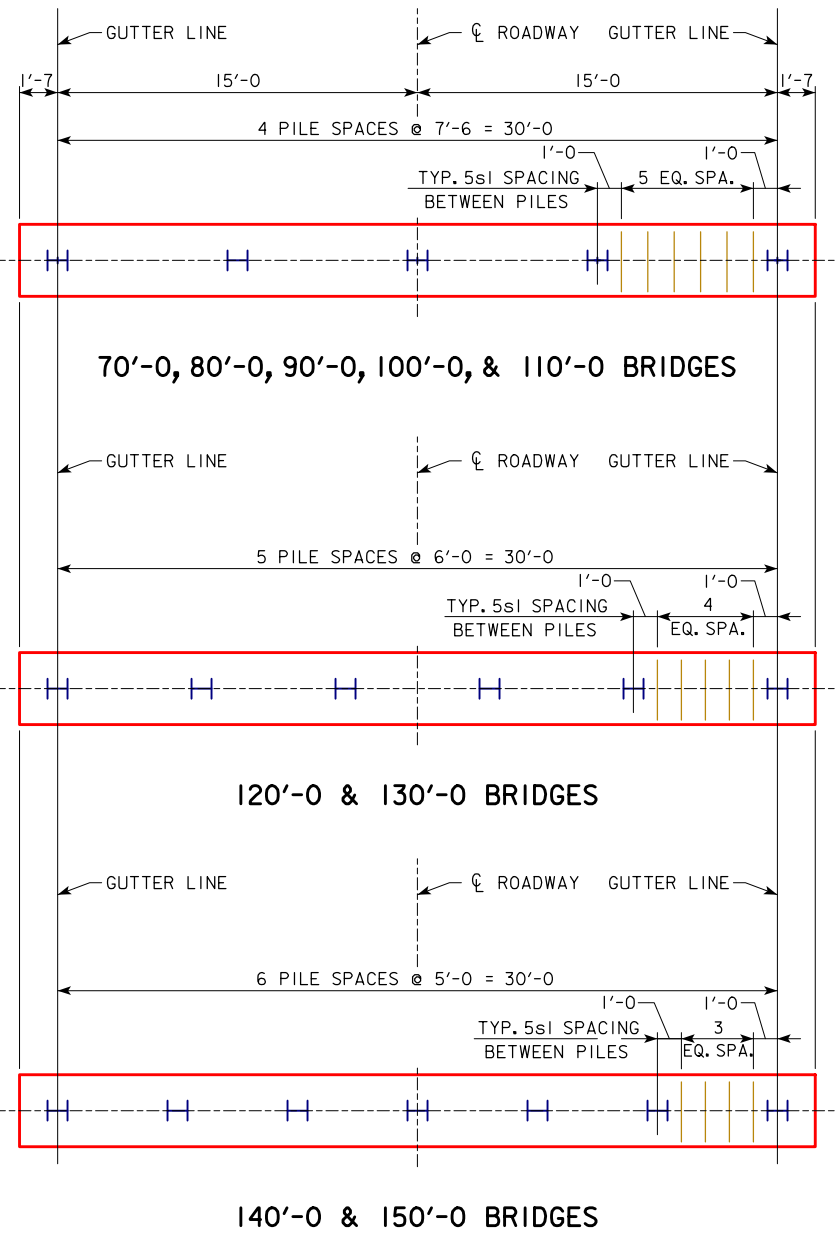

PILE PLAN - 0° SKEW STEEL PILING

ABUTMENT NOTES:

ALL PILING HP 10x42.

THE CONCRETE AND REINFORCING STEEL FOR THE WINGS IS INCLUDED WITH THE SUPERSTRUCTURE.

DETAILS ON THIS SHEET ARE TO BE USED ONLY WHEN ABUTMENTS ARE PLACED ON STEEL PILES. IF ROCK IS ENCOUNTERED CLOSER THAN 12'-0 BELOW ABUTMENT FOOTING, SPECIAL ANALYSIS MAY BE REQUIRED.

THE MINIMUM CLEAR DISTANCE FROM THE FACE OF THE CONCRETE TO NEAR REINFORCING BAR IS TO BE 2 INCHES UNLESS OTHERWISE NOTED OR SHOWN.

STEEL ABUTMENT PILES SHALL BE DRIVEN TO FULL PENETRATION IF PRACTICABLE BUT IN NO CASE TO A BEARING VALUE LESS THAN SHOWN IN DESIGN PLANS.

ALL REINFORCING STEEL IS TO BE GRADE 60.

ABUTMENT PILING WAS DESIGNED FOR HL-93 LOADING WITH AN ALLOWANCE FOR 20 LBS. PER SQ. FT. FUTURE WEARING SURFACE.

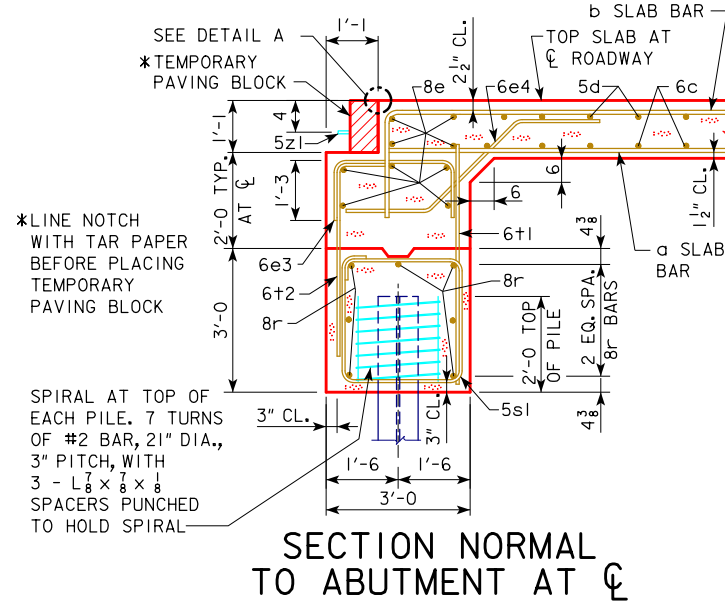

SECTION NORMAL TO ABUTMENT AT ROADWAY CENTERLINE

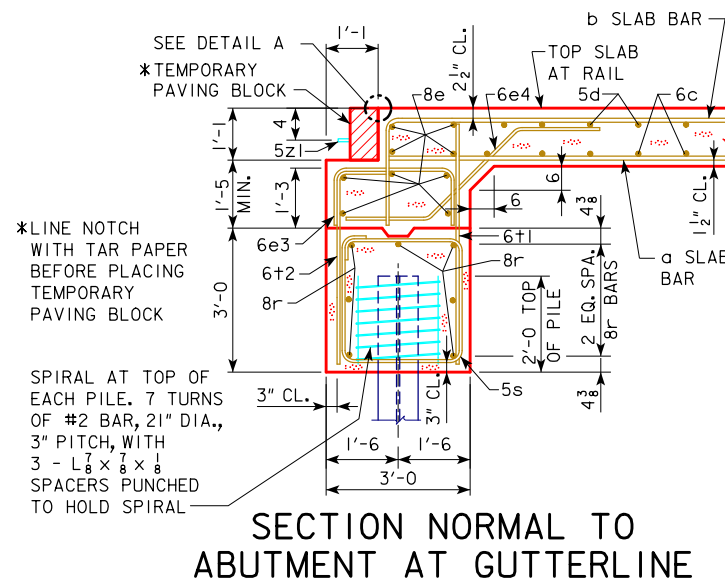

SECTION NORMAL TO ABUTMENT AT GUTTERLINE

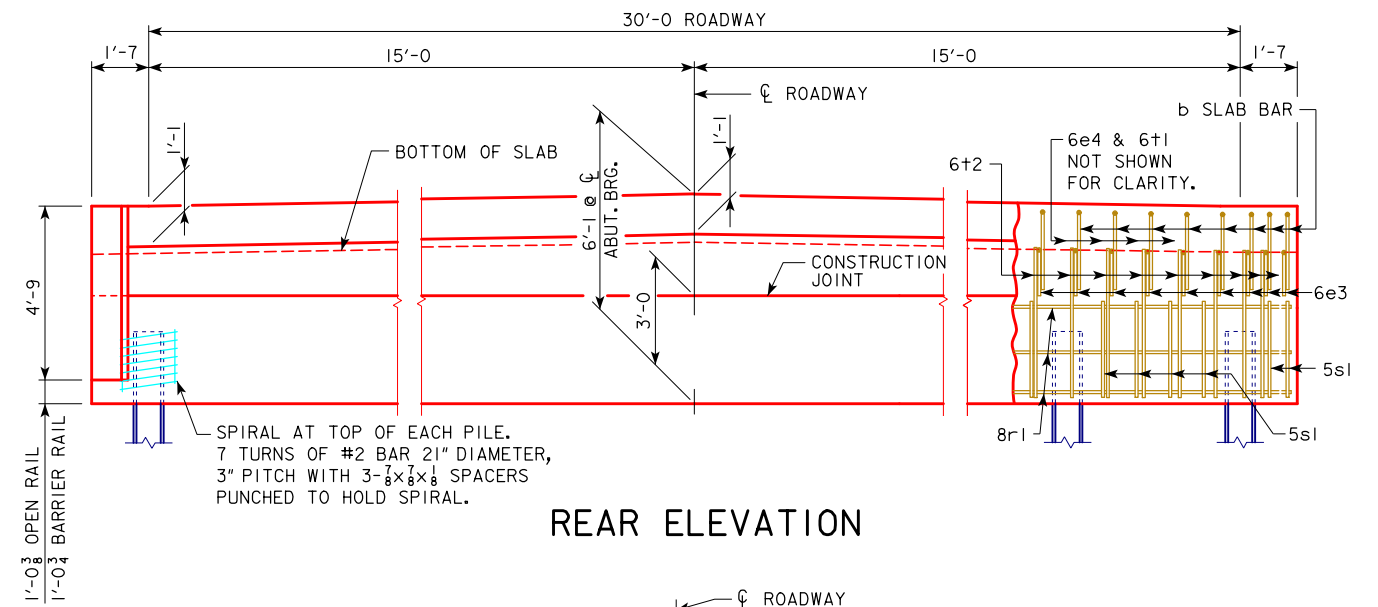
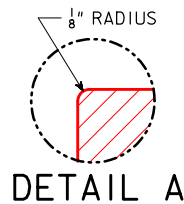

REAR ELEVATION

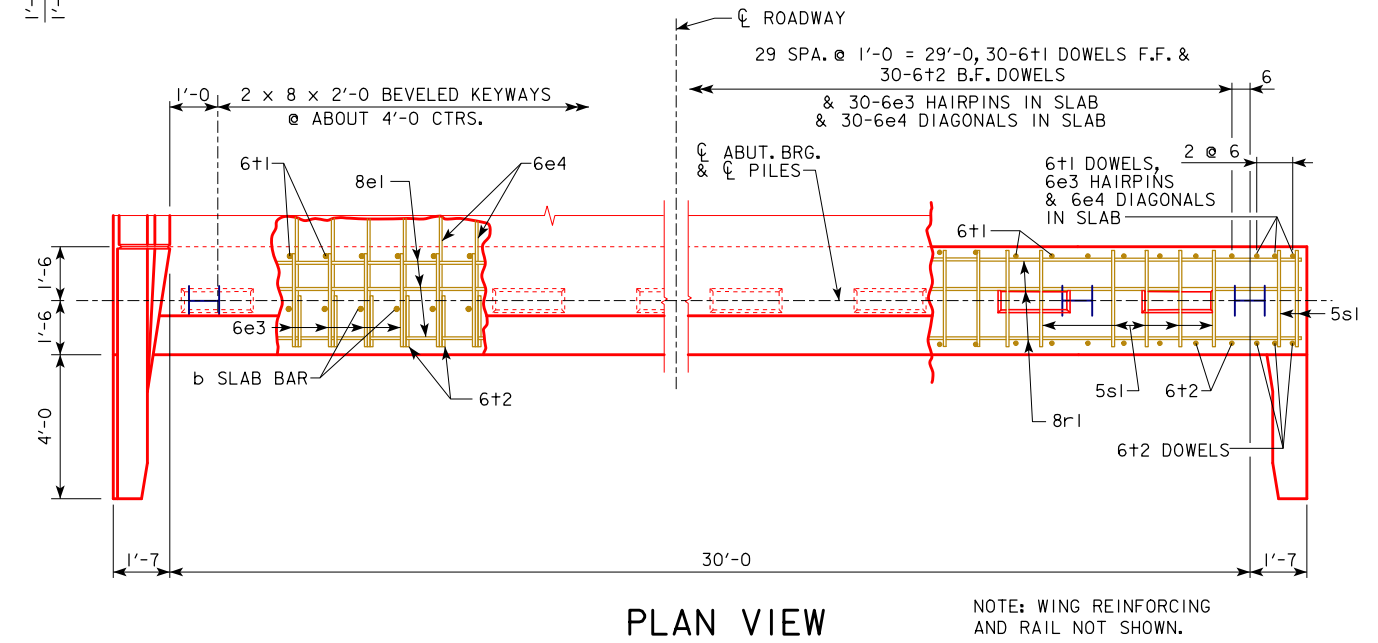

PLAN VIEW

NOTE: WING REINFORCING AND RAIL NOT SHOWN.

6e3, 6e4, AND 8e1 ARE INCLUDED WITH SUPERSTRUCTURE QUANTITIES.

NUMBER OF PILES AND ABUTMENT DESIGN LOADS									
BRIDGE LENGTH	70'-0	80'-0	90'-0	100'-0	110'-0	120'-0	130'-0	140'-0	150'-0
PILING - NUMBER	5	5	5	5	5	6	6	7	7
PU, STRENGTH I DESIGN LOAD - KIPS	377	402	426	456	485	519	561	Δ 646	Δ 684

Δ INCLUDES DYNAMIC LOAD ALLOWANCE

NOTE: PU, STRENGTH I DESIGN LOAD (KIPS) IS NOT THE VALUE USED IN THE FIELD FOR DRIVING PILES.

09-2020
LATEST REVISION DATE

APPROVED BY BRIDGE ENGINEER

IOWADOT Highway Division

STANDARD DESIGN - 30' ROADWAY, 3 SPAN BRIDGES

CONTINUOUS CONCRETE
SLAB BRIDGES

NOVEMBER, 2006

ABUTMENT DETAILS
0° SKEW - STEEL PILING

J30-34-06

REVISED 10-2013; REVISION FOR LRFD PILE DESIGN PU, STRENGTH LOADS IN TABLE.
REVISED 09-2020; UPDATED BRIDGE ENGINEER SIGNATURE. CHANGED PAVING BLOCK LIFTING HOOP BAR MARK, (WAS 5x1).

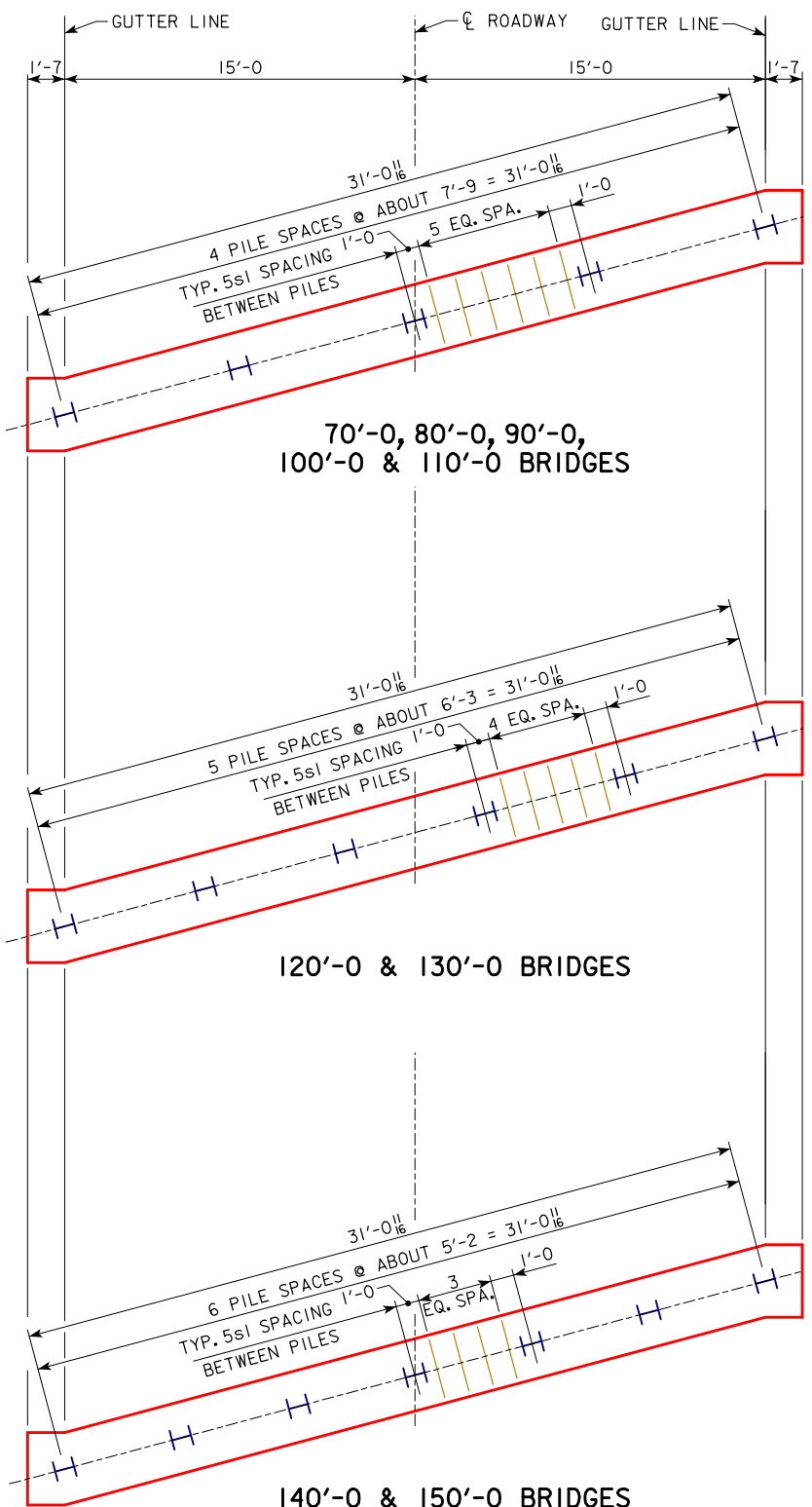

70'-0, 80'-0, 90'-0,
100'-0 & 110'-0 BRIDGES

120'-0 & 130'-0 BRIDGES

140'-0 & 150'-0 BRIDGES

**PILE PLAN - 15° SKEW
STEEL PILING**

NUMBER OF PILES AND ABUTMENT DESIGN LOADS									
BRIDGE LENGTH	70'-0	80'-0	90'-0	100'-0	110'-0	120'-0	130'-0	140'-0	150'-0
PILING - NUMBER	5	5	5	5	5	6	6	7	7
PU, STRENGTH I DESIGN LOAD - KIPS	381	406	429	460	489	522	555	Δ 650	Δ 688

Δ INCLUDES DYNAMIC LOAD ALLOWANCE
NOTE: PU, STRENGTH I DESIGN LOAD (KIPS) IS NOT THE VALUE USED IN THE FIELD FOR DRIVING PILES.

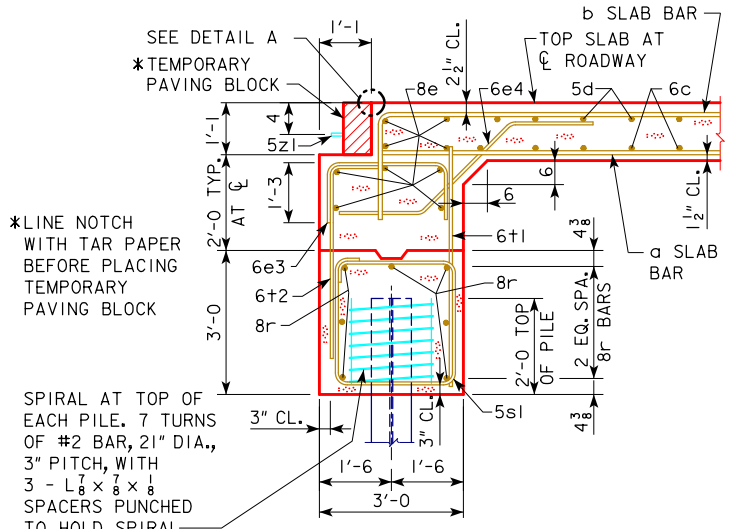

SECTION NORMAL TO ABUTMENT AT ROADWAY

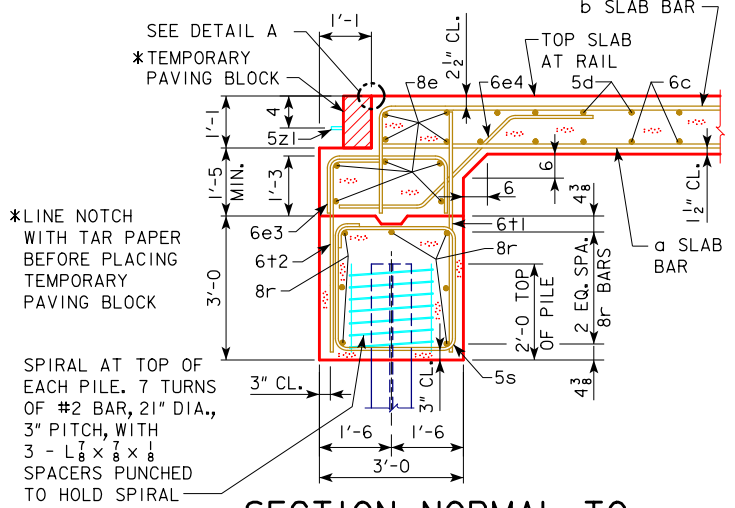

SECTION NORMAL TO ABUTMENT AT GUTTERLINE

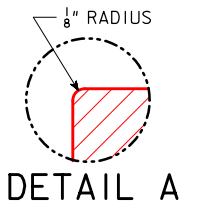

ABUTMENT NOTES:

- ALL PILING HP 10x42.
- THE CONCRETE AND REINFORCING STEEL FOR THE WINGS IS INCLUDED WITH THE SUPERSTRUCTURE.
- DETAILS ON THIS SHEET ARE TO BE USED ONLY WHEN ABUTMENTS ARE PLACED ON STEEL PILES. IF ROCK IS ENCOUNTERED CLOSER THAN 12'-0" BELOW ABUTMENT FOOTING, SPECIAL ANALYSIS MAY BE REQUIRED.
- THE MINIMUM CLEAR DISTANCE FROM THE FACE OF THE CONCRETE TO NEAR REINFORCING BAR IS TO BE 2 INCHES UNLESS OTHERWISE NOTED OR SHOWN.
- STEEL ABUTMENT PILES SHALL BE DRIVEN TO FULL PENETRATION IF PRACTICABLE BUT IN NO CASE TO A BEARING VALUE LESS THAN SHOWN IN DESIGN PLANS.
- ALL REINFORCING STEEL IS TO BE GRADE 60.
- ABUTMENT PILING WAS DESIGNED FOR HL-93 LOADING WITH AN ALLOWANCE FOR 20 LBS. PER SQ. FT. FUTURE WEARING SURFACE.

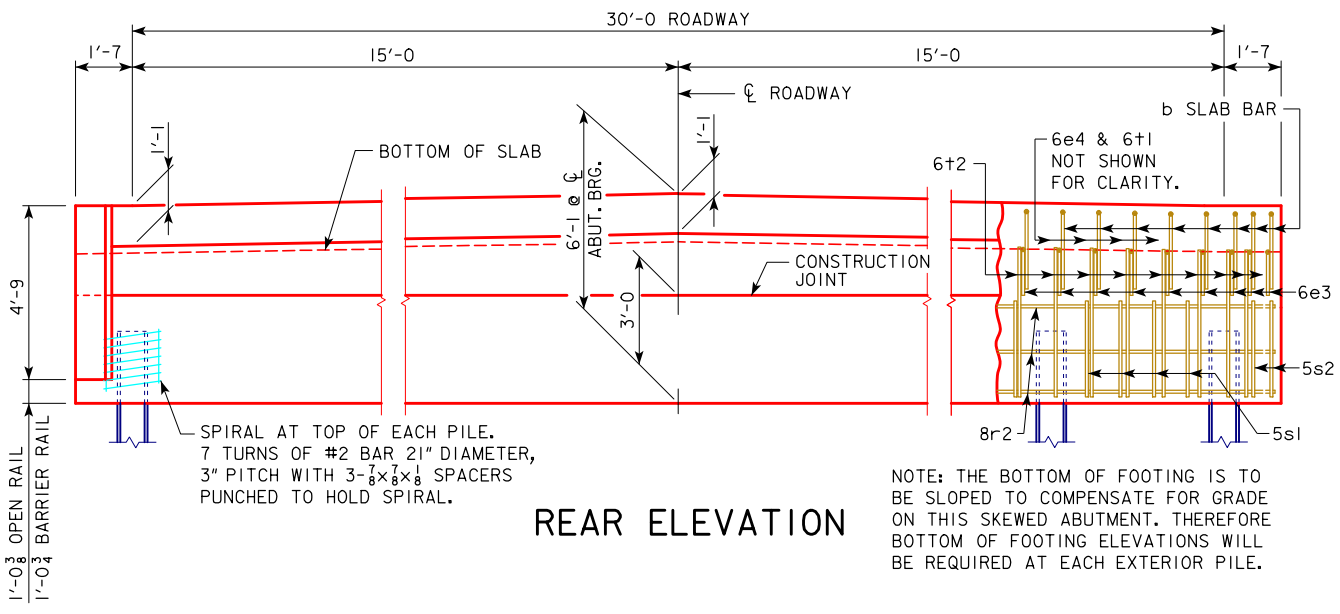

REAR ELEVATION

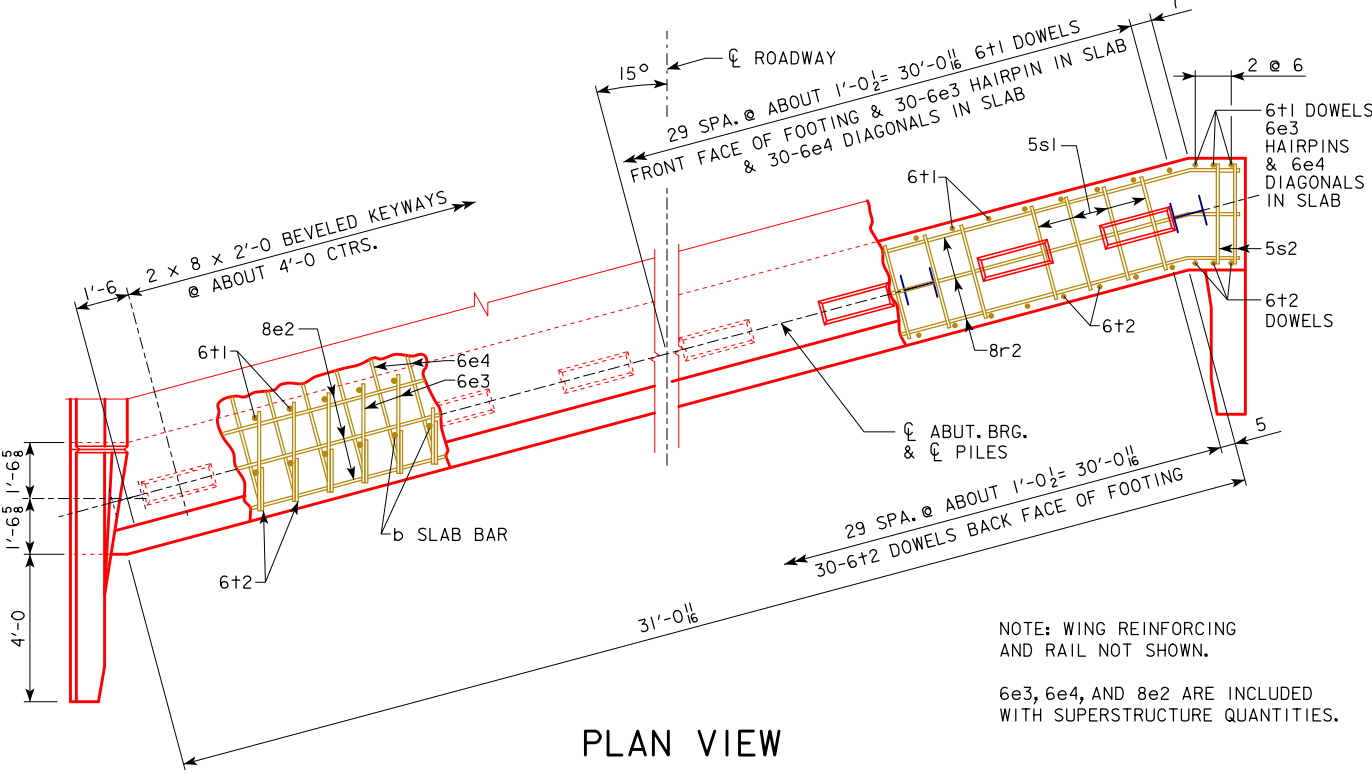

PLAN VIEW

09-2020 LATEST REVISION DATE APPROVED BY BRIDGE ENGINEER	 STANDARD DESIGN - 30' ROADWAY, 3 SPAN BRIDGES CONTINUOUS CONCRETE SLAB BRIDGES NOVEMBER, 2006
	ABUTMENT DETAILS 15° SKEW - STEEL PILING
	J30-35-06

REVISED 06-2013: REVISION FOR LRFD PILE DESIGN.
REVISED 09-2020: UPDATED BRIDGE ENGINEER SIGNATURE. CHANGED PAVING BLOCK LIFTING HOOP BAR MARK, (WAS 5x1).

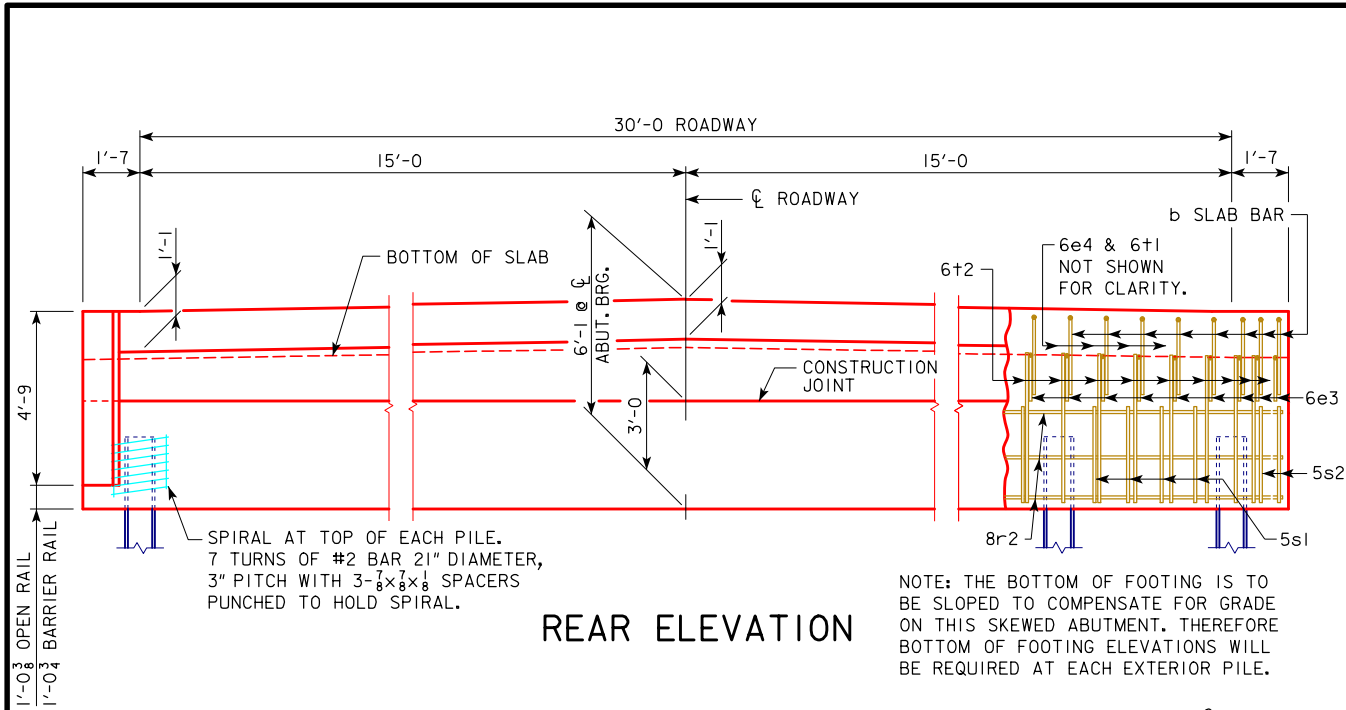

REAR ELEVATION

NOTE: THE BOTTOM OF FOOTING IS TO BE SLOPED TO COMPENSATE FOR GRADE ON THIS SKEWED ABUTMENT. THEREFORE BOTTOM OF FOOTING ELEVATIONS WILL BE REQUIRED AT EACH EXTERIOR PILE.

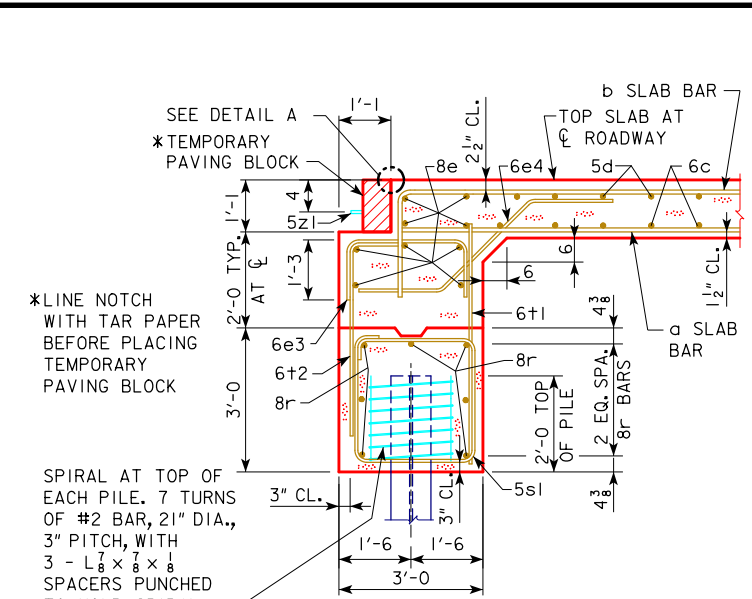

SECTION NORMAL TO ABUTMENT AT CL

*LINE NOTCH WITH TAR PAPER BEFORE PLACING TEMPORARY PAVING BLOCK

SPIRAL AT TOP OF EACH PILE. 7 TURNS OF #2 BAR, 21" DIA., 3" PITCH, WITH 3 - L₈ x 7/8 x 1/8 SPACERS PUNCHED TO HOLD SPIRAL

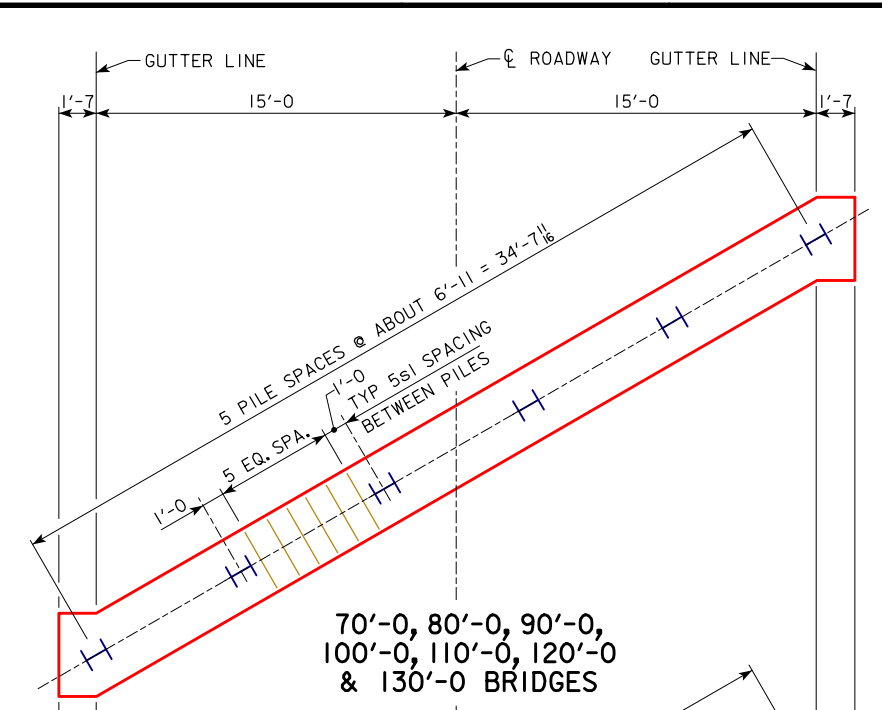

70'-0, 80'-0, 90'-0, 100'-0, 110'-0, 120'-0 & 130'-0 BRIDGES

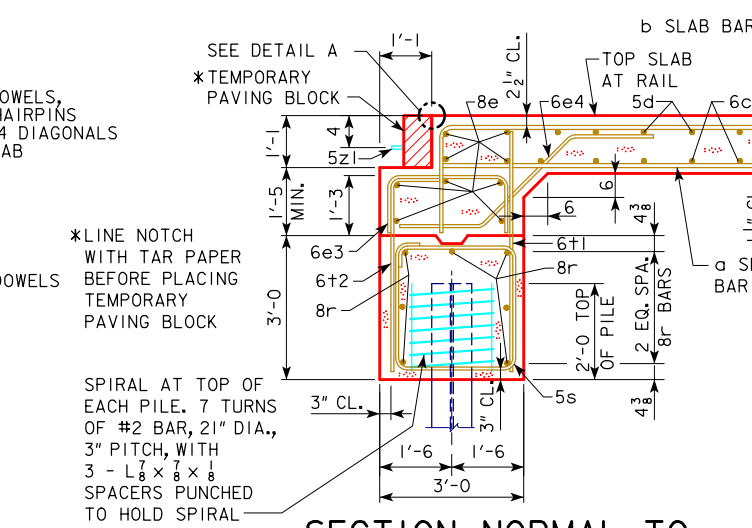

SECTION NORMAL TO ABUTMENT AT GUTTERLINE

*LINE NOTCH WITH TAR PAPER BEFORE PLACING TEMPORARY PAVING BLOCK

SPIRAL AT TOP OF EACH PILE. 7 TURNS OF #2 BAR, 21" DIA., 3" PITCH, WITH 3 - L₈ x 7/8 x 1/8 SPACERS PUNCHED TO HOLD SPIRAL

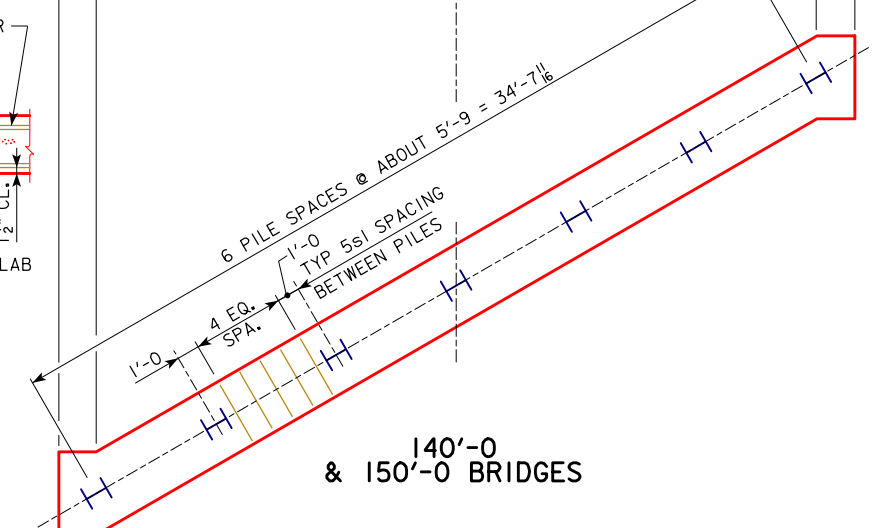

140'-0 & 150'-0 BRIDGES

PILE PLAN - 30° SKEW STEEL PILING

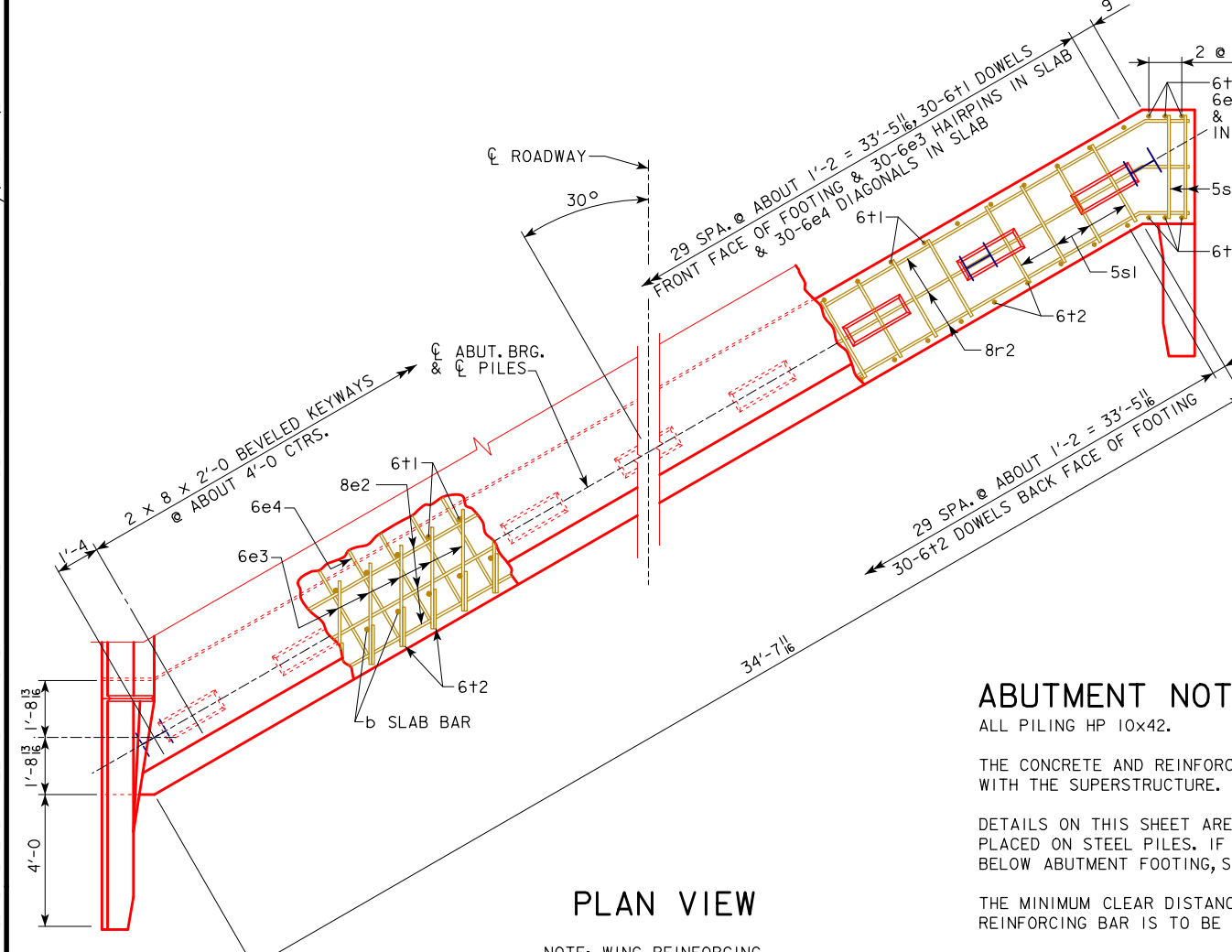

PLAN VIEW

NOTE: WING REINFORCING AND RAIL NOT SHOWN.
6e3, 6e4, AND 8e2 ARE INCLUDED WITH SUPERSTRUCTURE QUANTITIES.

ABUTMENT NOTES:

- ALL PILING HP 10x42.
- THE CONCRETE AND REINFORCING STEEL FOR THE WINGS IS INCLUDED WITH THE SUPERSTRUCTURE.
- DETAILS ON THIS SHEET ARE TO BE USED ONLY WHEN ABUTMENTS ARE PLACED ON STEEL PILES. IF ROCK IS ENCOUNTERED CLOSER THAN 12'-0" BELOW ABUTMENT FOOTING, SPECIAL ANALYSIS MAY BE REQUIRED.
- THE MINIMUM CLEAR DISTANCE FROM THE FACE OF THE CONCRETE TO NEAR REINFORCING BAR IS TO BE 2 INCHES UNLESS OTHERWISE NOTED OR SHOWN.
- STEEL ABUTMENT PILES SHALL BE DRIVEN TO FULL PENETRATION IF PRACTICABLE BUT IN NO CASE TO A BEARING VALUE LESS THAN SHOWN IN DESIGN PLANS.
- ALL REINFORCING STEEL IS TO BE GRADE 60.
- ABUTMENT PILING WAS DESIGNED FOR HL-93 LOADING WITH AN ALLOWANCE FOR 20 LBS. PER SQ. FT. FUTURE WEARING SURFACE.

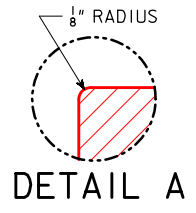

DETAIL A

NUMBER OF PILES AND ABUTMENT DESIGN LOADS									
BRIDGE LENGTH	70'-0	80'-0	90'-0	100'-0	110'-0	120'-0	130'-0	140'-0	150'-0
PILING - NUMBER	6	6	6	6	6	6	6	7	7
PU, STRENGTH I DESIGN LOAD - KIPS	393	418	442	472	501	535	567	Δ 663	Δ 701

Δ INCLUDES DYNAMIC LOAD ALLOWANCE
NOTE: PU, STRENGTH I DESIGN LOAD (KIPS) IS NOT THE VALUE USED IN THE FIELD FOR DRIVING PILES.

09-2020
LATEST REVISION DATE
[Signature]
APPROVED BY BRIDGE ENGINEER

IOWADOT Highway Division
STANDARD DESIGN - 30' ROADWAY, 3 SPAN BRIDGES
CONTINUOUS CONCRETE SLAB BRIDGES
NOVEMBER, 2006
30° ABUTMENT DETAILS
30° SKEW - STEEL PILING J30-36-06

REVISED 06-2013; REVISION FOR LRFD PILE DESIGN.
REVISED 09-2020; UPDATED BRIDGE ENGINEER SIGNATURE. CHANGED PAVING BLOCK LIFTING HOOP BAR MARK, (WAS 5x1).

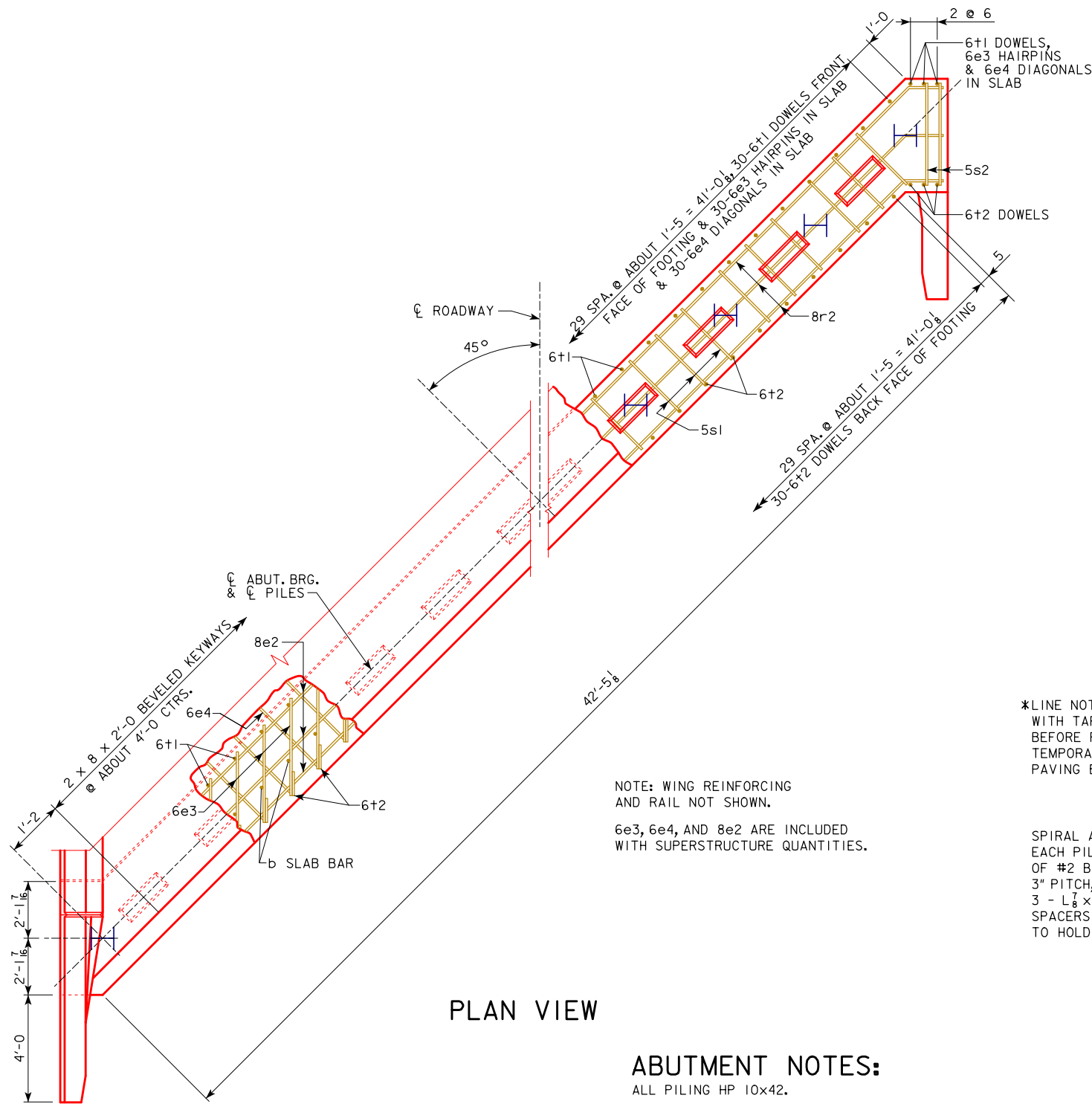

PLAN VIEW

ABUTMENT NOTES:

- ALL PILING HP 10x42.
- THE CONCRETE AND REINFORCING STEEL FOR THE WINGS IS INCLUDED WITH THE SUPERSTRUCTURE.
- DETAILS ON THIS SHEET ARE TO BE USED ONLY WHEN ABUTMENTS ARE PLACED ON STEEL PILES. IF ROCK IS ENCOUNTERED CLOSER THAN 12'-0" BELOW ABUTMENT FOOTING, SPECIAL ANALYSIS MAY BE REQUIRED.
- THE MINIMUM CLEAR DISTANCE FROM THE FACE OF THE CONCRETE TO NEAR REINFORCING BAR IS TO BE 2 INCHES UNLESS OTHERWISE NOTED OR SHOWN.
- STEEL ABUTMENT PILES SHALL BE DRIVEN TO FULL PENETRATION IF PRACTICABLE BUT IN NO CASE TO A BEARING VALUE LESS THAN SHOWN IN DESIGN PLANS.
- ALL REINFORCING STEEL IS TO BE GRADE 60.
- ABUTMENT PILING WAS DESIGNED FOR HL-93 LOADING WITH AN ALLOWANCE FOR 20 LBS. PER SQ. FT. FUTURE WEARING SURFACE.

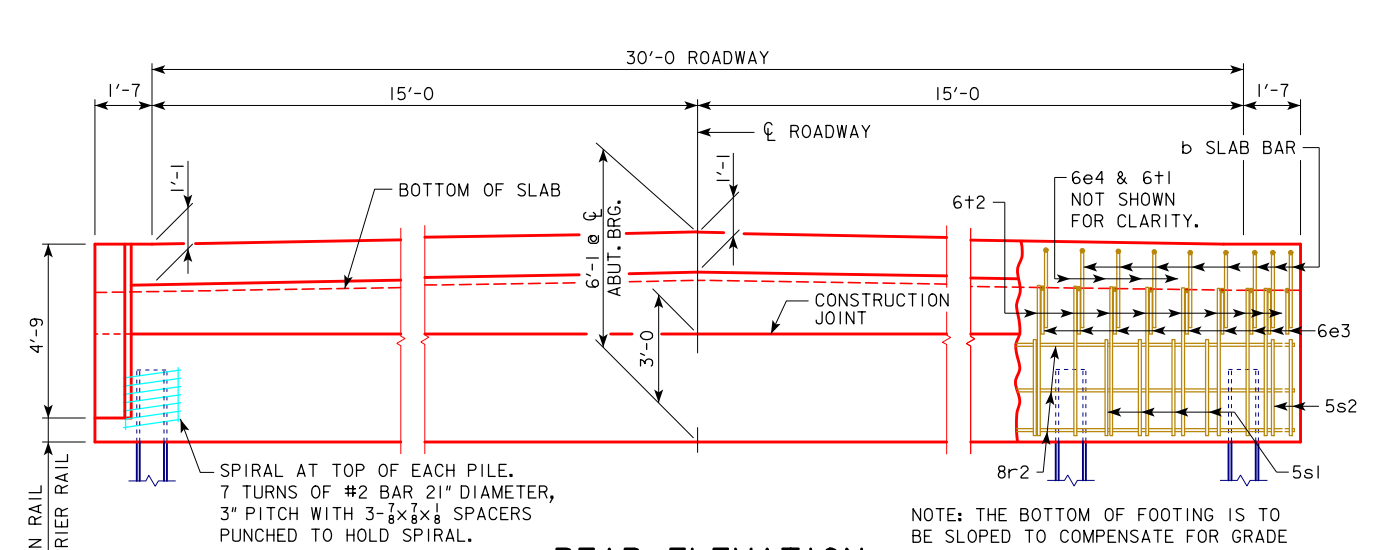

REAR ELEVATION

NOTE: THE BOTTOM OF FOOTING IS TO BE SLOPED TO COMPENSATE FOR GRADE ON THIS SKEWED ABUTMENT. THEREFORE BOTTOM OF FOOTING ELEVATIONS WILL BE REQUIRED AT EACH EXTERIOR PILE.

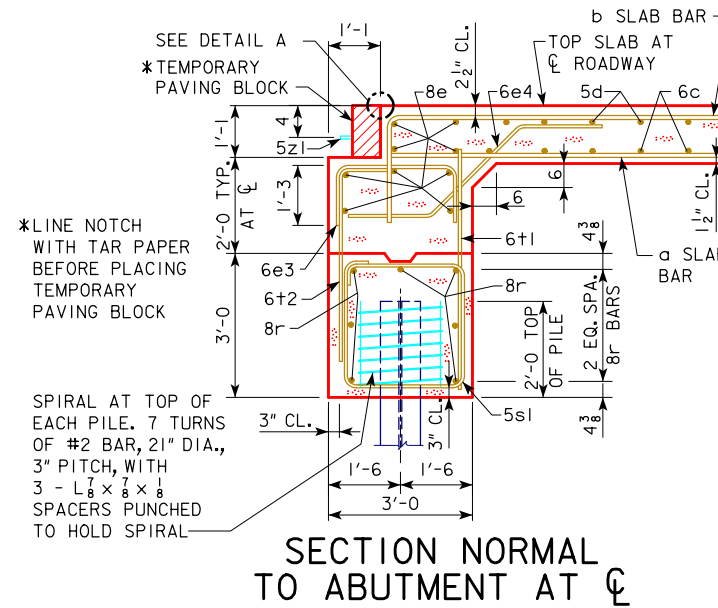

SECTION NORMAL TO ABUTMENT AT ROADWAY CL.

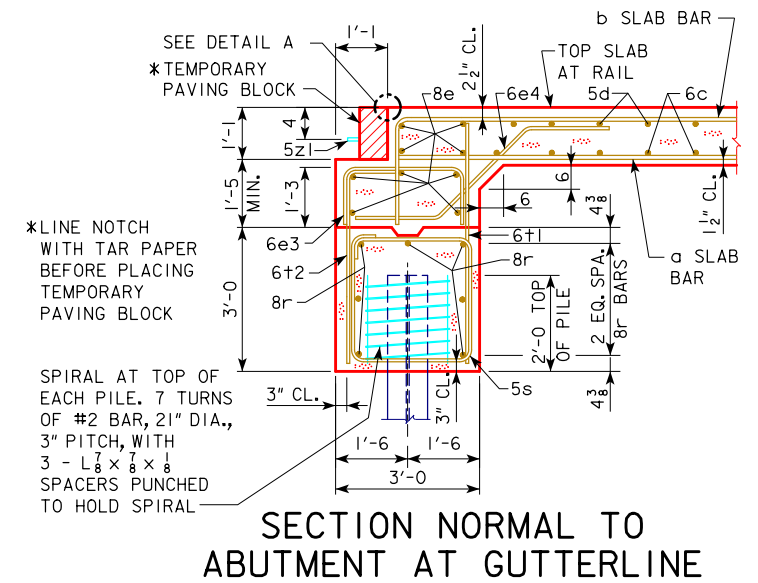

SECTION NORMAL TO ABUTMENT AT GUTTERLINE

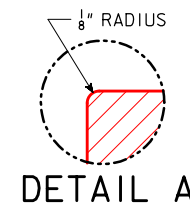

DETAIL A

<p>09-2020 LATEST REVISION DATE</p>	<p>APPROVED BY BRIDGE ENGINEER</p>	<p>IOWADOT Highway Division</p> <p>STANDARD DESIGN - 30' ROADWAY, 3 SPAN BRIDGES</p> <p>CONTINUOUS CONCRETE SLAB BRIDGES</p> <p>NOVEMBER, 2006</p>
<p>ABUTMENT DETAILS 45° SKEW - STEEL PILING</p>		<p>J30-37-06</p>

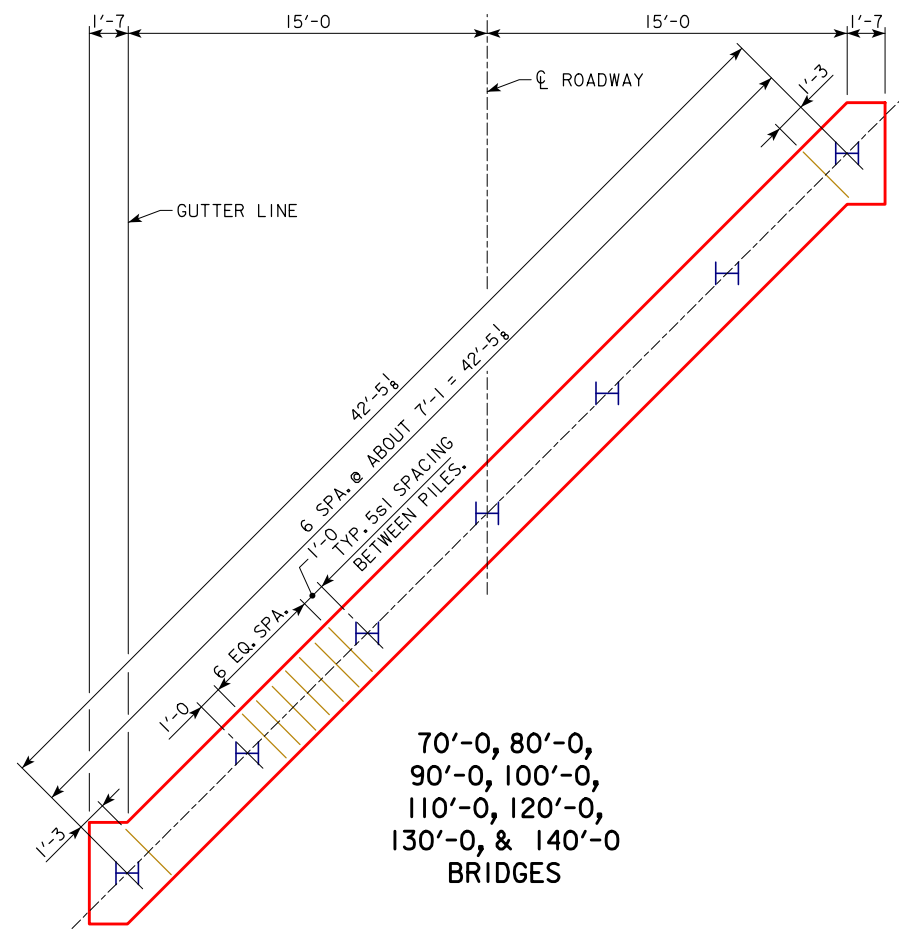

70'-0, 80'-0,
90'-0, 100'-0,
110'-0, 120'-0,
130'-0, & 140'-0
BRIDGES

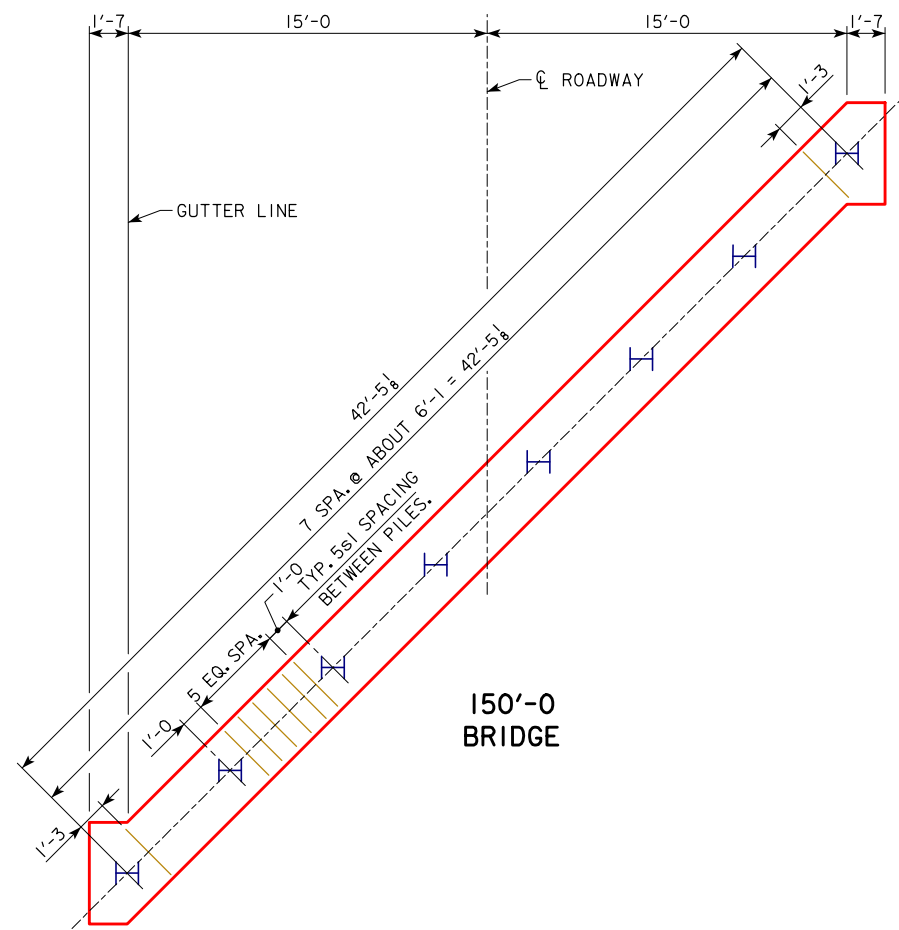

150'-0
BRIDGE



NOTE:
ALL PILES ARE TO BE ORIENTED WITH WEBS PERPENDICULAR
TO THE ϕ OF THE ROADWAY AS SHOWN.

PILE PLAN - 45° SKEW
STEEL PILING

NOTE: ALL PILING HP 10x42.

NUMBER OF PILES AND ABUTMENT DESIGN LOADS									
BRIDGE LENGTH	70'-0	80'-0	90'-0	100'-0	110'-0	120'-0	130'-0	140'-0	150'-0
PILING - NUMBER	7	7	7	7	7	7	7	7	8
PU, STRENGTH I DESIGN LOAD - KIPS	419	444	468	499	528	562	595	Δ 691	Δ 729

Δ INCLUDES DYNAMIC LOAD ALLOWANCE
NOTE: PU, STRENGTH I DESIGN LOAD (KIPS) IS NOT THE VALUE USED IN THE FIELD FOR DRIVING PILES.

09-2020 LATEST REVISION DATE  APPROVED BY BRIDGE ENGINEER	 STANDARD DESIGN - 30' ROADWAY, 3 SPAN BRIDGES CONTINUOUS CONCRETE SLAB BRIDGES NOVEMBER, 2006
	ABUTMENT DETAILS 45° SKEW - STEEL PILING
	J30-38-06

REVISED 06-2013: REVISION FOR LRFD PILE DESIGN.
 REVISED 09-2020: UPDATED BRIDGE ENGINEER SIGNATURE.

BILL OF REINFORCING STEEL - ONE ABUTMENT - 0° SKEW

BRIDGE LENGTH																					
MARK	LOCATION	SHAPE	LENGTH	NO.	WEIGHT	NO.	WEIGHT	NO.	WEIGHT	NO.	WEIGHT	NO.	WEIGHT	NO.	WEIGHT	NO.	WEIGHT	NO.	WEIGHT		
8r1	ABUTMENT FOOTING LONGITUDINAL		32'-10"	7	614	7	614	7	614	7	614	7	614	7	614	7	614	7	614	7	614
5s1	ABUTMENT FOOTING HOOPS		11'-0"	28	321	28	321	28	321	28	321	29	333	29	333	28	321	28	321		
6+1	FOOTING TO SLAB DOWELS		5'-0"	36	270	36	270	36	270	36	270	36	270	36	270	36	270	36	270	36	270
6+2	FOOTING TO SLAB DOWELS		5'-7"	36	302	36	302	36	302	36	302	36	302	36	302	36	302	36	302	36	302
#2	PILE SPIRAL		38'-6"	5	32	5	32	5	32	5	32	5	32	6	39	6	39	7	45	7	45
	SPIRAL SPACERS - L 7/8 X 7/8 X 1/8 X 0.70		1'-10"	15	19	15	19	15	19	15	19	15	19	18	23	18	23	21	27	21	27
REINFORCING STEEL - TOTAL (LBS.)					1558		1558		1558		1558		1558		1581		1581		1579		1579

BILL OF REINFORCING STEEL - ONE ABUTMENT - 15° SKEW

BRIDGE LENGTH																					
MARK	LOCATION	SHAPE	LENGTH	NO.	WEIGHT	NO.	WEIGHT	NO.	WEIGHT	NO.	WEIGHT	NO.	WEIGHT	NO.	WEIGHT	NO.	WEIGHT	NO.	WEIGHT	NO.	WEIGHT
8r2	ABUTMENT FOOTING LONGITUDINAL		33'-11"	7	634	7	634	7	634	7	634	7	634	7	634	7	634	7	634	7	634
5s1	ABUTMENT FOOTING HOOPS		11'-0"	24	275	24	275	24	275	24	275	24	275	25	287	24	275	24	275	24	275
5s2	ABUTMENT FOOTING HOOPS		11'-3"	4	47	4	47	4	47	4	47	4	47	4	47	4	47	4	47	4	47
6+1	FOOTING TO SLAB DOWELS		5'-0"	36	270	36	270	36	270	36	270	36	270	36	270	36	270	36	270	36	270
6+2	FOOTING TO SLAB DOWELS		5'-7"	36	302	36	302	36	302	36	302	36	302	36	302	36	302	36	302	36	302
#2	PILE SPIRAL		38'-6"	5	32	5	32	5	32	5	32	5	32	6	39	6	39	7	45	7	45
	SPIRAL SPACERS - L 7/8 X 7/8 X 1/8 X 0.70		1'-10"	15	19	15	19	15	19	15	19	15	19	18	23	18	23	21	27	21	27
REINFORCING STEEL - TOTAL (LBS.)					1579		1579		1579		1579		1579		1602		1602		1600		1600

BILL OF REINFORCING STEEL - ONE ABUTMENT - 30° SKEW

BRIDGE LENGTH																					
MARK	LOCATION	SHAPE	LENGTH	NO.	WEIGHT	NO.	WEIGHT	NO.	WEIGHT	NO.	WEIGHT	NO.	WEIGHT	NO.	WEIGHT	NO.	WEIGHT	NO.	WEIGHT	NO.	WEIGHT
8r2	ABUTMENT FOOTING LONGITUDINAL		37'-6"	7	701	7	701	7	701	7	701	7	701	7	701	7	701	7	701	7	701
5s1	ABUTMENT FOOTING HOOPS		11'-0"	30	344	30	344	30	344	30	344	30	344	30	344	30	344	30	344	30	344
5s2	ABUTMENT FOOTING HOOPS		11'-11"	4	50	4	50	4	50	4	50	4	50	4	50	4	50	4	50	4	50
6+1	FOOTING TO SLAB DOWELS		5'-0"	36	270	36	270	36	270	36	270	36	270	36	270	36	270	36	270	36	270
6+2	FOOTING TO SLAB DOWELS		5'-7"	36	302	36	302	36	302	36	302	36	302	36	302	36	302	36	302	36	302
#2	PILE SPIRAL		38'-6"	6	39	6	39	6	39	6	39	6	39	6	39	6	39	7	45	7	45
	SPIRAL SPACERS - L 7/8 X 7/8 X 1/8 X 0.70		1'-10"	18	23	18	23	18	23	18	23	18	23	18	23	18	23	21	27	21	27
REINFORCING STEEL - TOTAL (LBS.)					1729		1729		1729		1729		1729		1729		1729		1739		1739

BILL OF REINFORCING STEEL - ONE ABUTMENT - 45° SKEW

BRIDGE LENGTH																					
MARK	LOCATION	SHAPE	LENGTH	NO.	WEIGHT	NO.	WEIGHT	NO.	WEIGHT	NO.	WEIGHT	NO.	WEIGHT	NO.	WEIGHT	NO.	WEIGHT	NO.	WEIGHT	NO.	WEIGHT
8r2	ABUTMENT FOOTING LONGITUDINAL		45'-3"	7	846	7	846	7	846	7	846	7	846	7	846	7	846	7	846	7	846
5s1	ABUTMENT FOOTING HOOPS		11'-0"	42	482	42	482	42	482	42	482	42	482	42	482	42	482	42	482	42	482
5s2	ABUTMENT FOOTING HOOPS		13'-6"	4	56	4	56	4	56	4	56	4	56	4	56	4	56	4	56	4	56
6+1	FOOTING TO SLAB DOWELS		5'-0"	36	270	36	270	36	270	36	270	36	270	36	270	36	270	36	270	36	270
6+2	FOOTING TO SLAB DOWELS		5'-7"	36	302	36	302	36	302	36	302	36	302	36	302	36	302	36	302	36	302
#2	PILE SPIRAL		38'-6"	7	45	7	45	7	45	7	45	7	45	7	45	7	45	7	45	8	51
	SPIRAL SPACERS - L 7/8 X 7/8 X 1/8 X 0.70		1'-10"	21	27	21	27	21	27	21	27	21	27	21	27	21	27	21	27	24	31
REINFORCING STEEL - TOTAL (LBS.)					2028		2028		2028		2028		2028		2028		2028		2028		2038

ESTIMATED QUANTITIES - ONE ABUT. - 0° SKEW

LOCATION	UNIT	QUANTITY									
BRIDGE LENGTH		70'-0"	80'-0"	90'-0"	100'-0"	110'-0"	120'-0"	130'-0"	140'-0"	150'-0"	
STRUCTURAL CONCRETE (BRIDGE)	C.Y.	11.1	11.1	11.1	11.1	11.1	11.1	11.1	11.1	11.1	11.1
REINFORCING STEEL	LBS.	1558	1558	1558	1558	1558	1581	1581	1579	1579	
STEEL PILING HP 10x42	NO.	5	5	5	5	5	6	6	7	7	
PREBORE HOLES	FT.	-	-	-	-	-	-	-	70	70	

ESTIMATED QUANTITIES - ONE ABUT. - 15° SKEW

LOCATION	UNIT	QUANTITY									
BRIDGE LENGTH		70'-0"	80'-0"	90'-0"	100'-0"	110'-0"	120'-0"	130'-0"	140'-0"	150'-0"	
STRUCTURAL CONCRETE (BRIDGE)	C.Y.	11.5	11.5	11.5	11.5	11.5	11.5	11.5	11.5	11.5	11.5
REINFORCING STEEL	LBS.	1579	1579	1579	1579	1579	1602	1602	1600	1600	
STEEL PILING HP 10x42	NO.	5	5	5	5	5	6	6	7	7	
PREBORE HOLES	FT.	-	-	-	-	-	-	-	70	70	

ESTIMATED QUANTITIES - ONE ABUT. - 30° SKEW

LOCATION	UNIT	QUANTITY									
BRIDGE LENGTH		70'-0"	80'-0"	90'-0"	100'-0"	110'-0"	120'-0"	130'-0"	140'-0"	150'-0"	
STRUCTURAL CONCRETE (BRIDGE)	C.Y.	12.8	12.8	12.8	12.8	12.8	12.8	12.8	12.8	12.8	12.8
REINFORCING STEEL	LBS.	1729	1729	1729	1729	1729	1729	1729	1739	1739	
STEEL PILING HP 10x42	NO.	6	6	6	6	6	6	6	7	7	
PREBORE HOLES	FT.	-	-	-	-	-	-	-	70	70	

ESTIMATED QUANTITIES - ONE ABUT. - 45° SKEW

LOCATION	UNIT	QUANTITY									
BRIDGE LENGTH		70'-0"	80'-0"	90'-0"	100'-0"	110'-0"	120'-0"	130'-0"	140'-0"	150'-0"	
STRUCTURAL CONCRETE (BRIDGE)	C.Y.	15.7	15.7	15.7	15.7	15.7	15.7	15.7	15.7	15.7	15.7
REINFORCING STEEL	LBS.	2028	2028	2028	2028	2028	2028	2028	2028	2038	
STEEL PILING HP 10x42	NO.	7	7	7	7	7	7	7	7	8	
PREBORE HOLES	FT.	-	-	-	-	-	-	-	70	80	

BENT BAR DETAILS

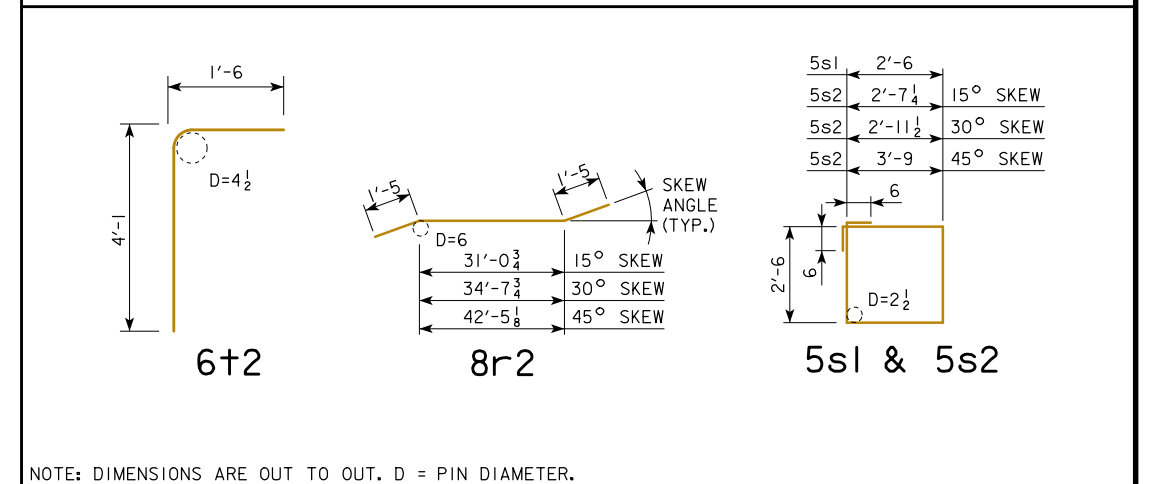

REVISED 07-2009; CONCRETE QUANTITIES CHANGED. REVISED 09-2020; UPDATED BRIDGE ENGINEER SIGNATURE.

09-2020 LATEST REVISION DATE APPROVED BY BRIDGE ENGINEER	 STANDARD DESIGN - 30' ROADWAY, 3 SPAN BRIDGES CONTINUOUS CONCRETE SLAB BRIDGES NOVEMBER, 2006
	ABUTMENT DETAILS STEEL PILING
	J30-39-06

TABLE OF BARRIER RAIL DIMENSIONS AND NUMBERS

BRIDGE LENGTH	70'-0				80'-0				90'-0				100'-0				110'-0				120'-0				130'-0				140'-0				150'-0				
	SKUEW	0°	15°	30°	45°	0°	15°	30°	45°	0°	15°	30°	45°	0°	15°	30°	45°	0°	15°	30°	45°	0°	15°	30°	45°	0°	15°	30°	45°	0°	15°	30°	45°	0°	15°	30°	45°
DIMENSION OR NUMBER	A (FT.-IN.)	81'-0	81'-1 1/4	81'-5 1/2	82'-3	91'-0	91'-1 1/4	91'-5 1/2	92'-3	101'-0	101'-1 1/4	101'-5 1/2	102'-3	111'-0	111'-1 1/4	111'-5 1/2	112'-3	121'-0	121'-1 1/4	121'-5 1/2	122'-3	131'-0	131'-1 1/4	131'-5 1/2	132'-3	141'-0	141'-1 1/4	141'-5 1/2	142'-3	151'-0	151'-1 1/4	151'-5 1/2	152'-3	161'-0	161'-1 1/4	161'-5 1/2	162'-3
	B (FT.-IN.)	67'-0	67'-1 1/4	67'-5 1/2	68'-3	77'-0	77'-1 1/4	77'-5 1/2	78'-3	87'-0	87'-1 1/4	87'-5 1/2	88'-3	97'-0	97'-1 1/4	97'-5 1/2	98'-3	107'-0	107'-1 1/4	107'-5 1/2	108'-3	117'-0	117'-1 1/4	117'-5 1/2	118'-3	127'-0	127'-1 1/4	127'-5 1/2	128'-3	137'-0	137'-1 1/4	137'-5 1/2	138'-3	147'-0	147'-1 1/4	147'-5 1/2	148'-3
	C	66	66	66	67	76	76	76	77	86	86	86	87	96	96	96	97	106	106	106	107	116	116	116	117	126	126	126	127	136	136	136	137	146	146	146	147
	D (FT.-IN.)	66'-0	66'-0	66'-0	67'-0	76'-0	76'-0	76'-0	77'-0	86'-0	86'-0	86'-0	87'-0	96'-0	96'-0	96'-0	97'-0	106'-0	106'-0	106'-0	107'-0	116'-0	116'-0	116'-0	117'-0	126'-0	126'-0	126'-0	127'-0	136'-0	136'-0	136'-0	137'-0	146'-0	146'-0	146'-0	147'-0
	E	67	67	67	68	77	77	77	78	87	87	87	88	97	97	97	98	107	107	107	108	117	117	117	118	127	127	127	128	137	137	137	138	147	147	147	148
	F (IN.)	6	6 5/8	8 3/4	7 1/2	6	6 5/8	8 3/4	7 1/2	6	6 5/8	8 3/4	7 1/2	6	6 5/8	8 3/4	7 1/2	6	6 5/8	8 3/4	7 1/2	6	6 5/8	8 3/4	7 1/2	6	6 5/8	8 3/4	7 1/2	6	6 5/8	8 3/4	7 1/2	6	6 5/8	8 3/4	7 1/2

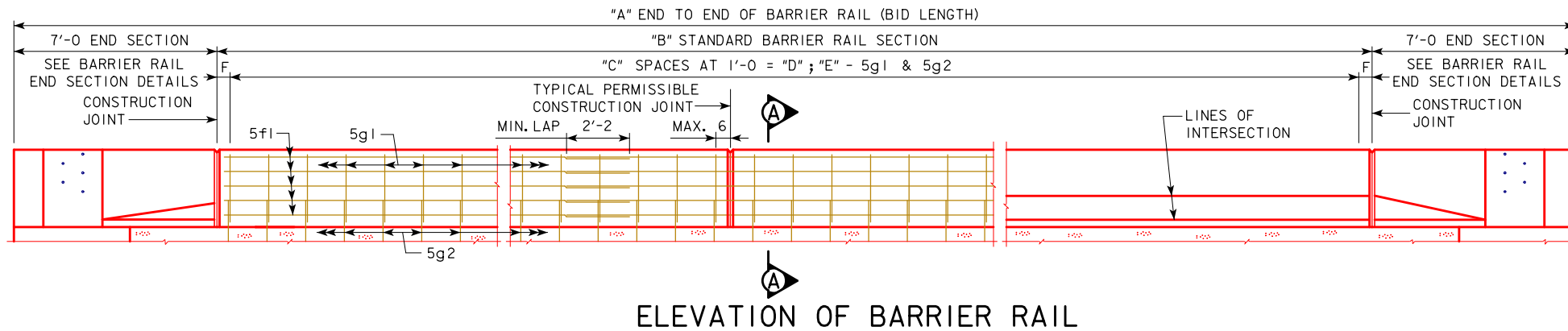

ELEVATION OF BARRIER RAIL

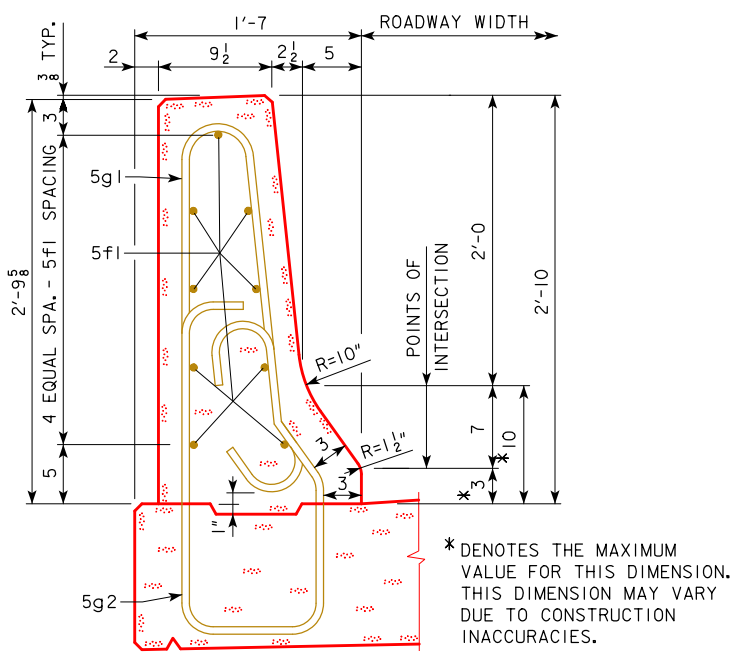

PART SECTION A-A

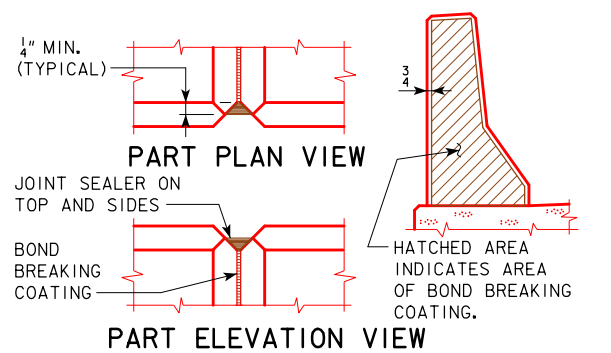

BARRIER RAIL JOINT DETAILS

BARRIER RAIL NOTES:

MINIMUM CLEAR DISTANCE FROM FACE OF CONCRETE TO NEAR REINFORCING BAR IS TO BE 2" UNLESS OTHERWISE NOTED OR SHOWN.

THE PERMISSIBLE CONSTRUCTION JOINTS ARE TO BE PLACED BETWEEN VERTICAL BARS AT A MINIMUM SPACING OF 20 FEET. CONSTRUCTION JOINT CONTACT SURFACES ARE TO BE COATED WITH AN APPROVED BOND BREAKER.

COST OF THE JOINT SEALER AND BOND BREAKER SHALL BE CONSIDERED INCIDENTAL TO OTHER CONSTRUCTION.

THE CONCRETE BARRIER RAIL IS TO BE BID ON A LINEAL FOOT BASIS. THE NUMBER OF LINEAL FEET OF BARRIER RAIL INSTALLED WILL BE PAID FOR AT THE CONTRACT PRICE PER LINEAL FOOT BASED ON PLAN QUANTITIES. PRICE BID FOR "CONCRETE BARRIER RAILING" SHALL BE FULL COMPENSATION FOR FURNISHING ALL MATERIAL, EXCLUDING REINFORCING STEEL, AND ALL OF THE EQUIPMENT AND LABOR REQUIRED TO ERECT THE RAIL IN ACCORDANCE WITH THESE PLANS AND CURRENT SPECIFICATIONS.

IF CONDUIT IS REQUIRED IN THIS PLAN THE RIGID STEEL CONDUIT, JUNCTION BOXES AND FITTINGS INCLUDING LABOR AND ANY ADDITIONAL WORK TO DO THE INSTALLATION IS CONSIDERED INCIDENTAL TO THE COST OF THE RAILING.

THE JOINT SEALER SHALL BE LIGHT GRAY NONSAG LATEX CAULKING SEALER MARKETED FOR OUTDOOR USE. NO TESTING OR CERTIFICATION IS REQUIRED.

TOP OF THE BARRIER RAIL IS TO BE PARALLEL TO THE THEORETICAL \bar{c} GRADE.

CROSS SECTIONAL AREA OF THE STANDARD SECTION OF THE BARRIER RAIL = 2.84 SQUARE FEET.

IF PLANS SPECIFY THAT THE REINFORCING STEEL IN THE SLAB BE EPOXY COATED, ALL BARRIER RAIL REINFORCING SHALL ALSO BE EPOXY COATED. OTHERWISE THE BARRIER RAIL REINFORCING SHALL NOT BE EPOXY COATED.

CONCRETE BARRIER RAILS PLACED USING THE SLIPFORM METHOD WILL REQUIRE THE USE OF A CLASS BR CONCRETE IN ACCORDANCE WITH ARTICLE 2513.03, A, 2, OF THE STANDARD SPECIFICATIONS. CAST-IN-PLACE BARRIER RAILS SHALL USE CLASS C MIX. CLASS D CONCRETE IS NOT PERMITTED FOR CONCRETE BARRIER RAILS (CAST-IN-PLACE OR SLIPFORMED METHOD).

REVISED 07-2009: BR CONCRETE ARTICLE NUMBER CHANGED.
REVISED 07-2016: REMOVED BARRIER RAIL NOTE STATING "ALL BARRIER RAIL REINFORCING STEEL IS TO BE INCLUDED WITH THE SUPERSTRUCTURE REINFORCING STEEL."
REVISED 09-2020: UPDATED BRIDGE ENGINEER SIGNATURE.

09-2020 LATEST REVISION DATE	 APPROVED BY BRIDGE ENGINEER	STANDARD DESIGN - 30' ROADWAY, 3 SPAN BRIDGES CONTINUOUS CONCRETE SLAB BRIDGES NOVEMBER, 2006	
		BARRIER RAIL DETAILS	J30-40-06

EPOXY REINFORCING STEEL-TWO BARRIER RAILS

BRIDGE LENGTH				70'-0			80'-0			90'-0			100'-0			110'-0			120'-0			130'-0			140'-0			150'-0		
SECTION	BAR	LOCATION	SHAPE	NO.	LENGTH	WEIGHT	NO.	LENGTH	WEIGHT	NO.	LENGTH	WEIGHT	NO.	LENGTH	WEIGHT	NO.	LENGTH	WEIGHT	NO.	LENGTH	WEIGHT	NO.	LENGTH	WEIGHT	NO.	LENGTH	WEIGHT			
STANDARD SECTION	5g1	VERTICAL	⏏	136	5'-11	839	156	5'-11	963	176	5'-11	1086	196	5'-11	1210	216	5'-11	1333	236	5'-11	1456	256	5'-11	1580	276	5'-11	1703	296	5'-11	1827
	5g2	VERTICAL	⏏	136	6'-10	969	156	6'-11	1125	176	7'-1	1300	196	7'-4	1499	216	7'-6	1690	236	7'-9	1908	256	7'-11	2114	276	8'-2	2351	296	8'-5	2598
	5-F1	LONGITUDINAL	—	36	35'-1	1317	54	27'-5	1544	54	30'-9	1732	54	34'-1	1920	54	37'-5	2107	72	31'-2	2340	72	33'-8	2528	72	36'-2	2716	72	38'-8	2904
		4 END SECTIONS @ 458 LBS.					1832			1832			1832			1832			1832			1832			1832			1832		
(INCLUDE WITH SUPERSTRUCTURE REINFORCING)					TOTAL (LBS.)	4957	TOTAL (LBS.)	5464	TOTAL (LBS.)	5950	TOTAL (LBS.)	6461	TOTAL (LBS.)	6962	TOTAL (LBS.)	7536	TOTAL (LBS.)	8054	TOTAL (LBS.)	8602	TOTAL (LBS.)	9161								

REINFORCING QUANTITIES SHOWN ARE BASED ON 45° SKEW BID LENGTHS.

BENT BAR DETAILS

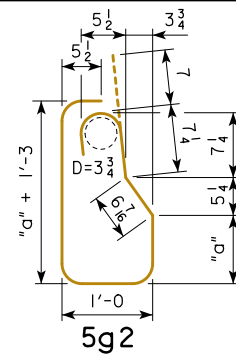
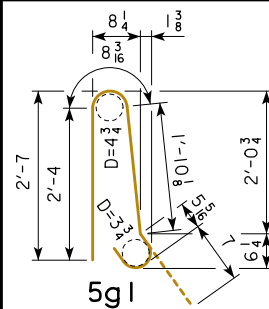

5g2 BARS		
BRIDGE	"a"	LENGTH
70'	1'-2	6'-10
80'	1'-2 3/4	6'-11
90'	1'-3 3/4	7'-1
100'	1'-5	7'-4
110'	1'-6	7'-6
120'	1'-7 1/2	7'-9
130'	1'-8 3/4	7'-11
140'	1'-10	8'-2
150'	1'-11 1/2	8'-5

NOTE: ALL DIMENSIONS ARE OUT TO OUT.
"D" = PIN DIAMETER.

CONCRETE PLACEMENT SUMMARY

BRIDGE LENGTH		70'-0	80'-0	90'-0	100'-0	110'-0	120'-0	130'-0	140'-0	150'-0
STANDARD SECTION *	2 x B @ 0.1052 CU. YDS. PER FT.	14.4	16.5	18.6	20.7	22.8	24.9	27.0	29.1	31.2
END SECTION	4 @ 0.65 CU. YDS.	2.6	2.6	2.6	2.6	2.6	2.6	2.6	2.6	2.6
TOTAL (CU. YDS.)		17.0	19.1	21.2	23.3	25.4	27.5	29.6	31.7	33.8

* SEE J30-40-06 FOR DIMENSION "B".
CONCRETE QUANTITIES SHOWN ARE
BASED ON 45° SKEW BID LENGTHS.

CONCRETE BARRIER RAIL QUANTITIES

BRIDGE LENGTH		UNIT	70'-0	80'-0	90'-0	100'-0	110'-0	120'-0	130'-0	140'-0	150'-0
CONCRETE BARRIER RAILING	0° SKEW	L.F.	162.0	182.0	202.0	222.0	242.0	262.0	282.0	302.0	322.0
CONCRETE BARRIER RAILING	15° SKEW	L.F.	162.2	182.2	202.2	222.2	242.2	262.2	282.2	302.2	322.2
CONCRETE BARRIER RAILING	30° SKEW	L.F.	162.9	182.9	202.9	222.9	242.9	262.9	282.9	302.9	322.9
CONCRETE BARRIER RAILING	45° SKEW	L.F.	164.5	184.5	204.5	224.5	244.5	264.5	284.5	304.5	324.5

REVISED 07-2009; WEIGHT OF END SECTIONS CHANGED AND IS REFLECTED IN TOTAL WEIGHT.
REVISED 09-2020; UPDATED BRIDGE ENGINEER SIGNATURE.

09-2020 LATEST REVISION DATE	 APPROVED BY BRIDGE ENGINEER	 STANDARD DESIGN - 30' ROADWAY, 3 SPAN BRIDGES CONTINUOUS CONCRETE SLAB BRIDGES NOVEMBER, 2006
		BARRIER RAIL DETAILS J30-41-06

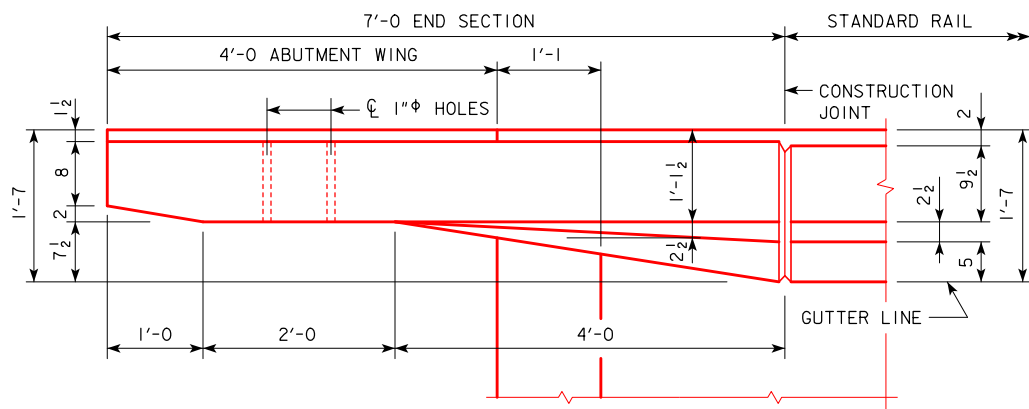

PART PLAN VIEW

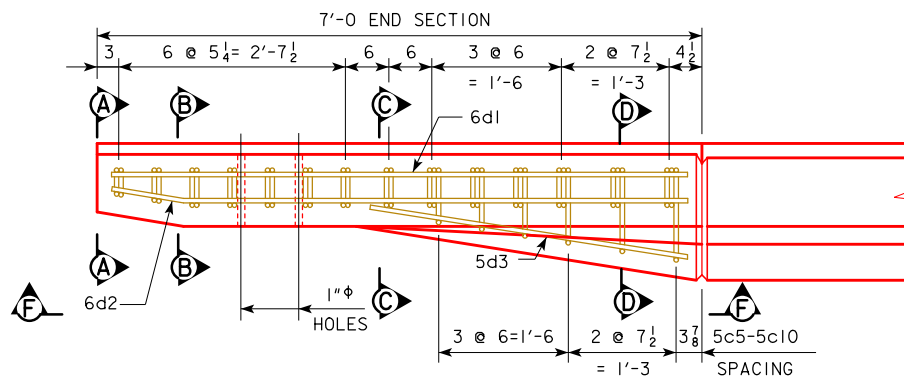

PART VIEW E-E

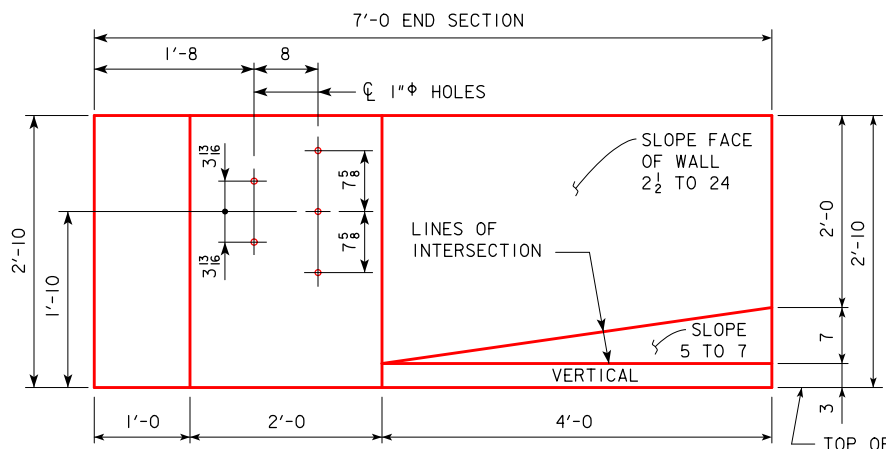

PART ELEVATION VIEW

PROVIDE 5 HOLES FORMED WITH 1" PLASTIC CONDUIT. COST TO BE INCLUDED IN PRICE BID FOR CONCRETE BARRIER RAILING.

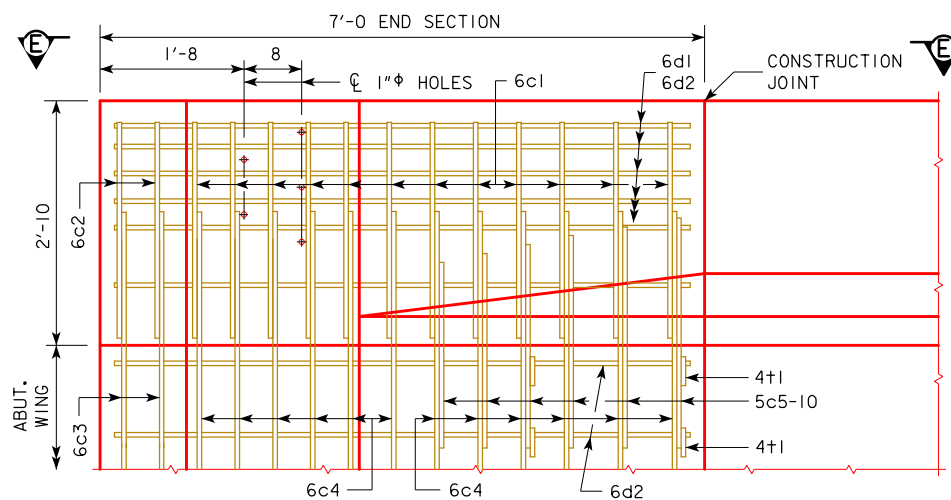

PART VIEW F-F

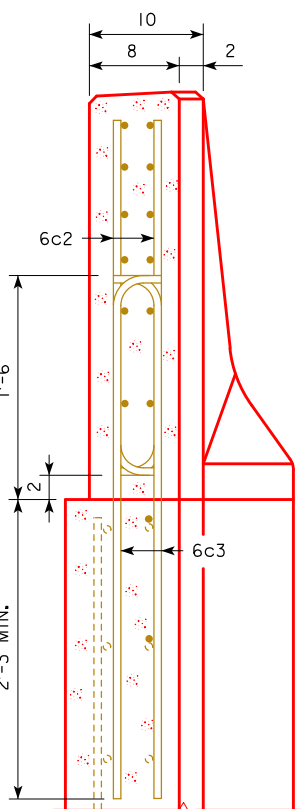

SECTION A-A

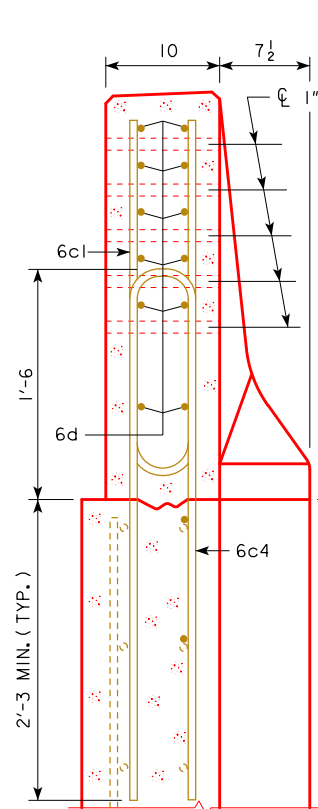

SECTION B-B

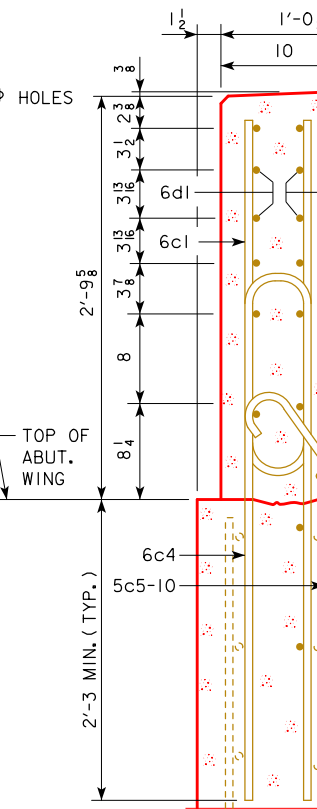

SECTION C-C

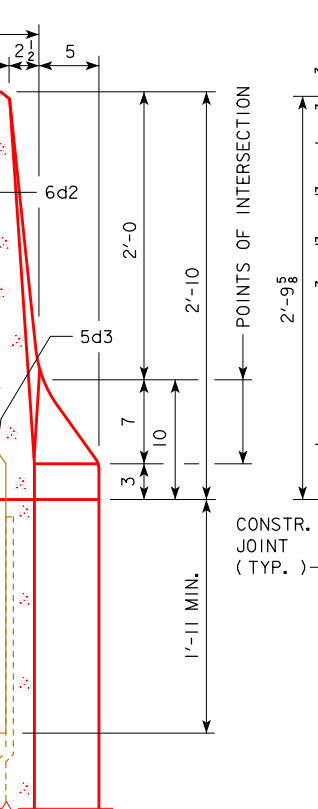

SECTION D-D

POINTS OF INTERSECTION

CONSTR. JOINT (TYP.)

NOTE: 4+1 PLACEMENT- 2 BARS EACH LEVEL OF 6d2 IN WING FOOTING.

NOTE: CONSTRUCTION JOINT BETWEEN TOP OF WING AND BARRIER RAIL IS ROUGHENED CONCRETE.

NOTE: THE 10" RADIUS AND 1 1/2" RADIUS ARE TYPICAL AND SHALL BE USED WHEN CONSTRUCTING THE CORNERS FOR SECTION A-A, SECTION B-B, SECTION C-C AND SECTION D-D.

NOTE: THE 6c4, 6c3, 5c5-10, 2-6d2 AND 4+1 BARS ARE TO BE PLACED WITH THE ABUTMENT WING. THE DETAILS FOR PLACEMENT ARE SHOWN ON THE WING ABUTMENT SHEET.

NOTE: DASHED LINES BELOW THE TOP OF WING ARE THE ABUTMENT WING REINFORCING STEEL. SEE WING ABUTMENT SHEET FOR PLACEMENT.

EPOXY REINFORCING STEEL - ONE END SECTION

BAR	LOCATION	SHAPE	NO.	LENGTH	WEIGHT	
6c1	VERTICAL	U	12	5'-6	99	
6c2	VERTICAL	U	4	2'-10	17	
6c3	VERTICAL	U	4	4'-1	25	
6c4	VERTICAL	U	12	8'-0	144	
5c5-10	VERTICAL	U	6	VARIES	23	
6d1	HORIZONTAL	—	6	6'-8	60	
6d2	HORIZONTAL	—	8	6'-9	81	
5d3	HORIZONTAL	—	1	3'-9	4	
4+1	ABUTMENT WING TIE BARS	U	4	VARIES	5	
(INCLUDE WITH BARRIER RAIL REINFORCING)					TOTAL WEIGHT (LBS.)	458

CONCRETE PLACEMENT SUMMARY

SECTION	TOTAL
BARRIER RAIL ONE END SECTION	0.65 CU. YD.

BENT BAR DETAILS

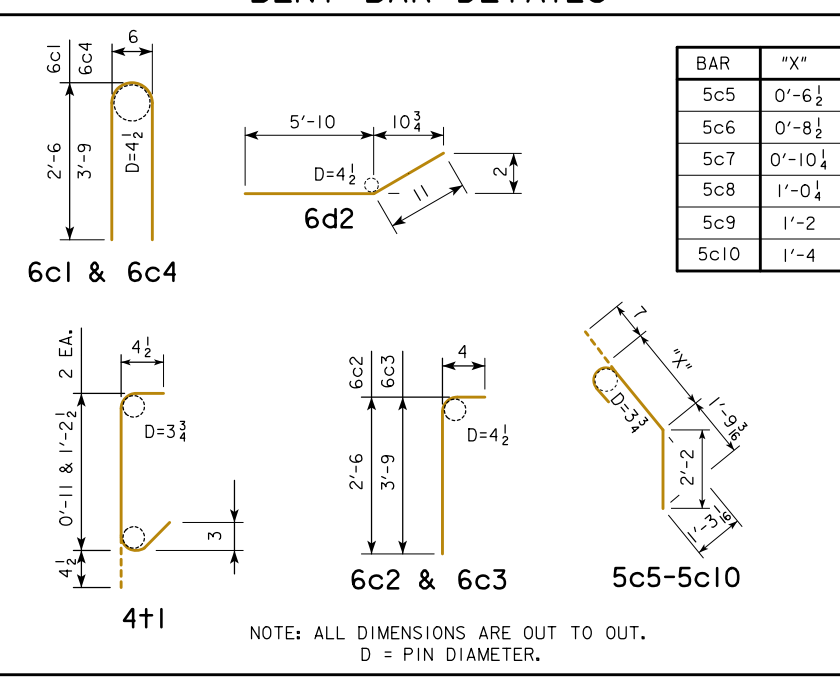

BAR	"X"
5c5	0'-6 1/2
5c6	0'-8 1/2
5c7	0'-10 1/4
5c8	1'-0 1/4
5c9	1'-2
5c10	1'-4

NOTE: ALL DIMENSIONS ARE OUT TO OUT. D = PIN DIAMETER.

REVISED 07-2009; CHANGED SHAPE OF 5c5-5c10 BARS.
REVISED 09-2020; UPDATED BRIDGE ENGINEER SIGNATURE. CHANGED SECTION A-A (WAS VIEW A-A).

09-2020
LATEST REVISION DATE

APPROVED BY BRIDGE ENGINEER

IOWADOT Highway Division

STANDARD DESIGN - 30' ROADWAY, 3 SPAN BRIDGES

CONTINUOUS CONCRETE SLAB BRIDGES

NOVEMBER, 2006

BARRIER RAIL END SECTION

J30-42-06

TABLE OF OPEN RAIL DIMENSIONS AND NUMBERS

CL-CL ABUT. BRG		70'-0				80'-0				90'-0				100'-0				110'-0				120'-0				130'-0				140'-0				150'-0			
		SKEW		0°	15°	30°	45°	0°	15°	30°	45°	0°	15°	30°	45°	0°	15°	30°	45°	0°	15°	30°	45°	0°	15°	30°	45°	0°	15°	30°	45°	0°	15°	30°	45°		
DIMENSION OR NUMBER	A (FT.-IN.)	81'-0	81'-1 1/4	81'-5 1/2	82'-3	91'-0	91'-1 1/4	91'-5 1/2	92'-3	101'-0	101'-1 1/4	101'-5 1/2	102'-3	111'-0	111'-1 1/4	111'-5 1/2	112'-3	121'-0	121'-1 1/4	121'-5 1/2	122'-3	131'-0	131'-1 1/4	131'-5 1/2	132'-3	141'-0	141'-1 1/4	141'-5 1/2	142'-3	151'-0	151'-1 1/4	151'-5 1/2	152'-3	161'-0	161'-1 1/4	161'-5 1/2	162'-3
	B (FT.-IN.)	67'-0	67'-1 1/4	67'-5 1/2	68'-3	77'-0	77'-1 1/4	77'-5 1/2	78'-3	87'-0	87'-1 1/4	87'-5 1/2	88'-3	97'-0	97'-1 1/4	97'-5 1/2	98'-3	107'-0	107'-1 1/4	107'-5 1/2	108'-3	117'-0	117'-1 1/4	117'-5 1/2	118'-3	127'-0	127'-1 1/4	127'-5 1/2	128'-3	137'-0	137'-1 1/4	137'-5 1/2	138'-3	147'-0	147'-1 1/4	147'-5 1/2	148'-3
	C	8	8	8	8	10	10	10	10	11	11	11	11	12	12	12	12	13	13	13	13	15	15	15	15	16	16	16	16	17	17	17	17	18	18	18	18
	D (FT.-IN.)	7'-10 1/2	7'-10 11/16	7'-11 3/16	7'-11 7/8	7'-3 5/8	7'-3 3/4	7'-4 3/16	7'-4 11/16	7'-6 3/16	7'-6 11/16	7'-7 1/16	7'-7 9/16	7'-9	7'-9 1/8	7'-9 7/16	7'-9 15/16	7'-11 1/16	7'-11 3/16	7'-11 1/2	7'-11 5/8	7'-6 3/8	7'-6 1/2	7'-6 3/4	7'-7 1/8	7'-8 1/4	7'-8 5/16	7'-8 5/8	7'-8 15/16	7'-9 7/8	7'-9 15/16	7'-10 3/16	7'-10 1/2	7'-11 5/16	7'-11 3/8	7'-11 5/8	7'-11 15/16

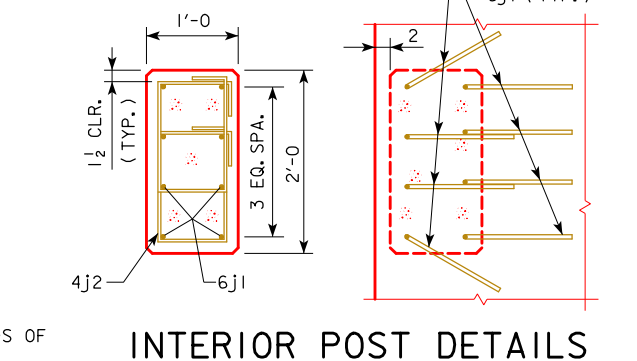
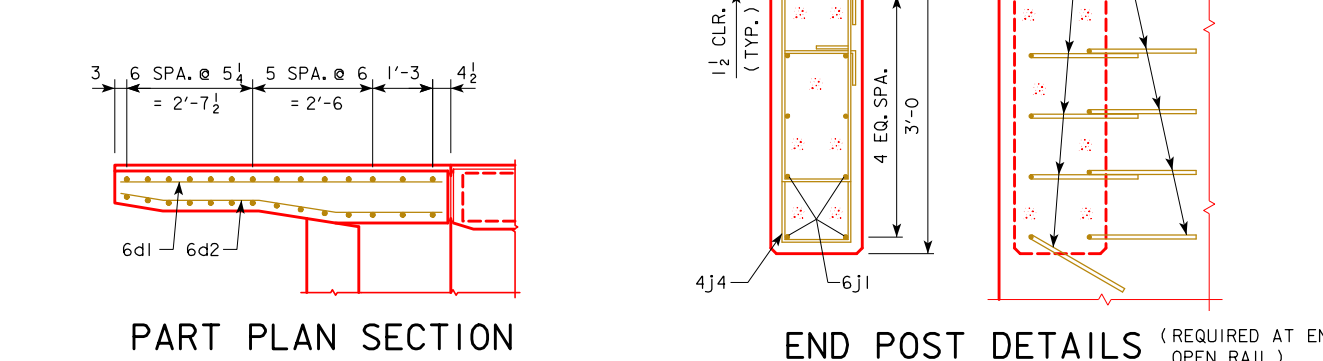
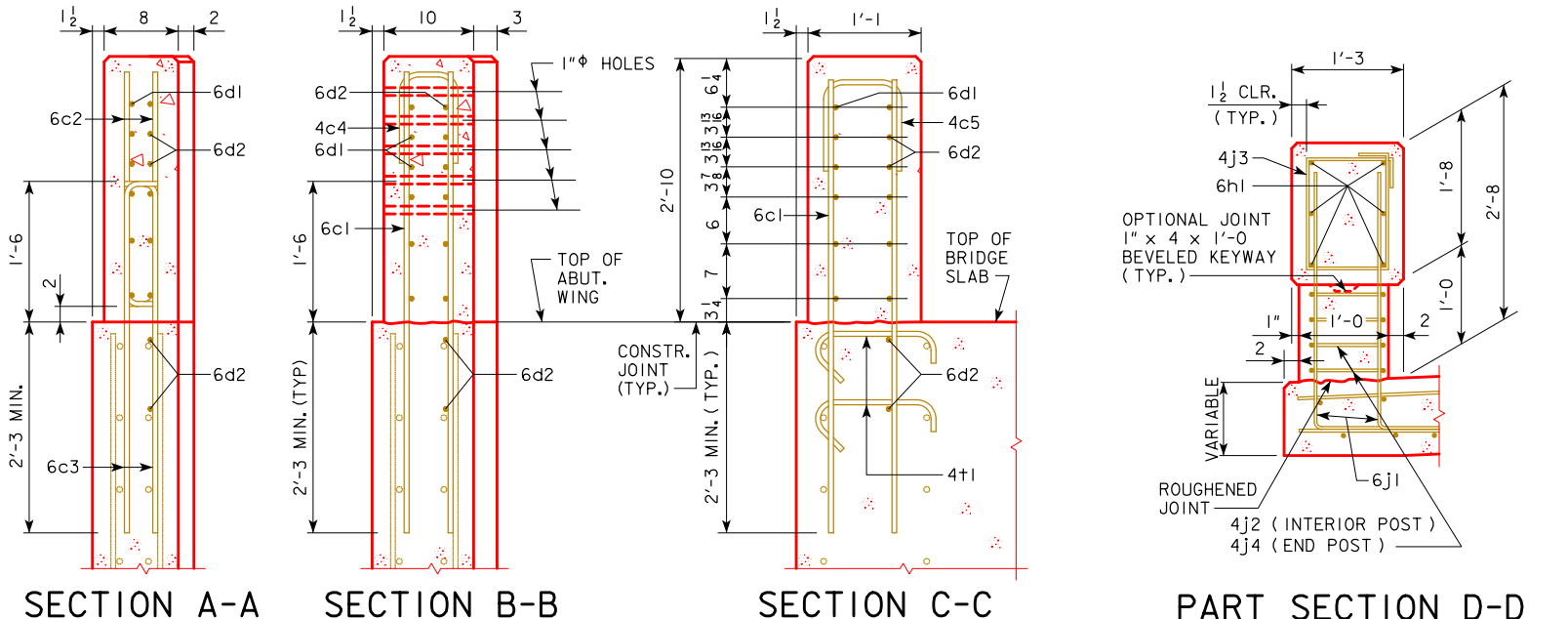
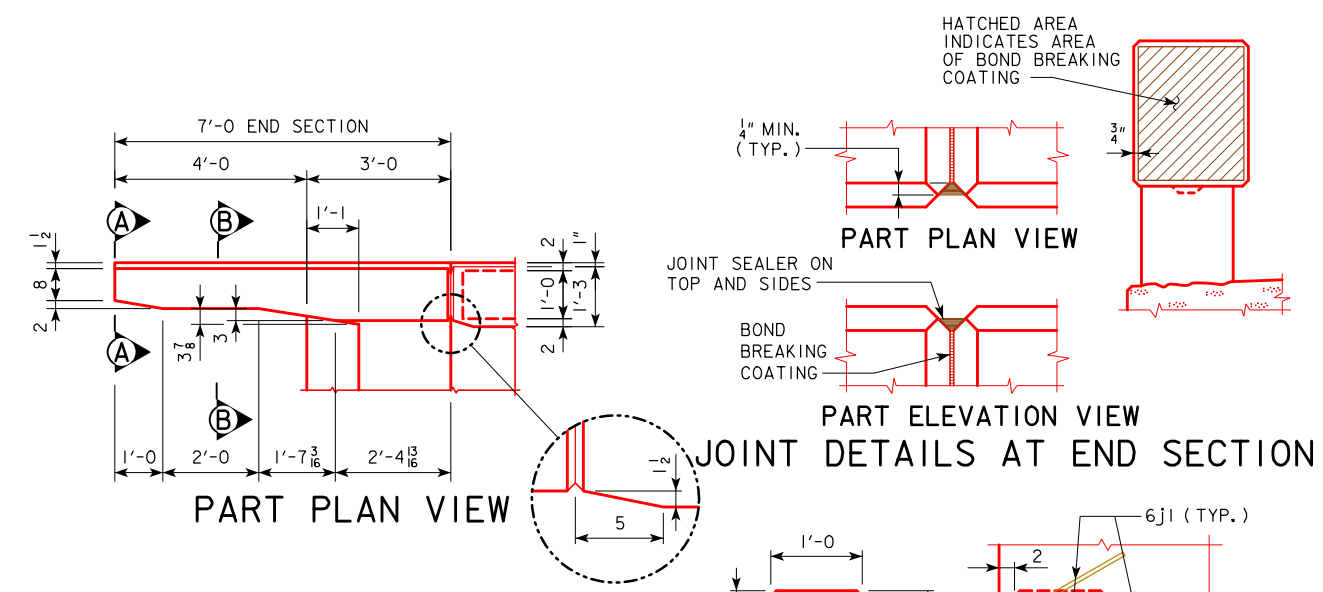
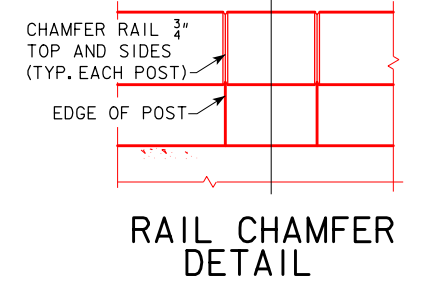
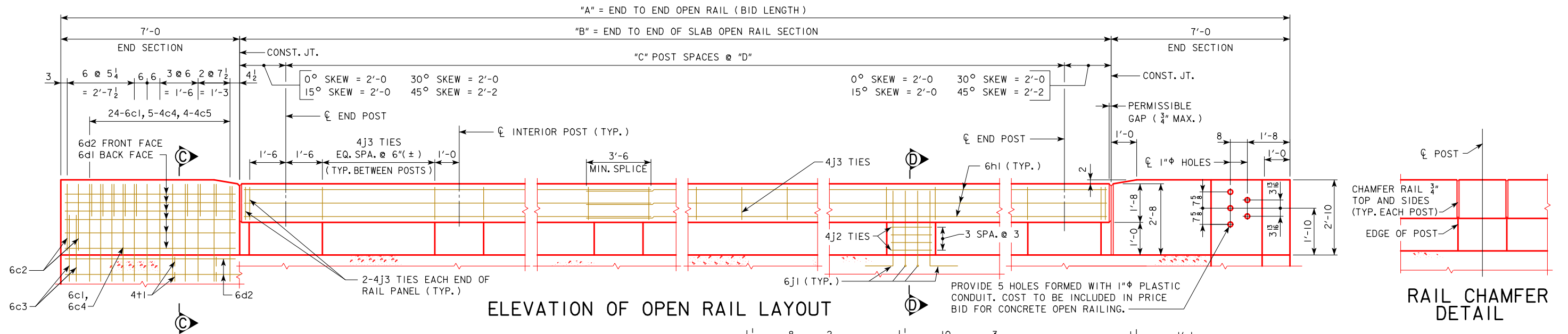

REVISED 12-2008; REVISED END SECTION SHAPE AND REINFORCEMENT. RAIL DEPTH CHANGED TO 1'-8".
 REVISED 09-2020; UPDATED BRIDGE ENGINEER SIGNATURE. CHANGED SECTION A-A (WAS VIEW A-A).

09-2020 LATEST REVISION DATE APPROVED BY BRIDGE ENGINEER		STANDARD DESIGN - 30' ROADWAY, 3 SPAN BRIDGES CONTINUOUS CONCRETE SLAB BRIDGES NOVEMBER, 2006	
	OPEN RAIL DETAILS (TL-4)	J30-43-06	

EPOXY REINFORCING STEEL-TWO OPEN RAILS

BRIDGE LENGTH			70'-0			80'-0			90'-0			100'-0			110'-0			120'-0			130'-0			140'-0			150'-0					
BAR	LOCATION	SHAPE	NO.	LENGTH	WEIGHT	NO.	LENGTH	WEIGHT	NO.	LENGTH	WEIGHT	NO.	LENGTH	WEIGHT	NO.	LENGTH	WEIGHT	NO.	LENGTH	WEIGHT	NO.	LENGTH	WEIGHT	NO.	LENGTH	WEIGHT						
6c1	VERTICAL	—	96	4'-11	709	96	4'-11	709	96	4'-11	709	96	4'-11	709	96	4'-11	709	96	4'-11	709	96	4'-11	709	96	4'-11	709						
6c2	VERTICAL	—	16	2'-10	68	16	2'-10	68	16	2'-10	68	16	2'-10	68	16	2'-10	68	16	2'-10	68	16	2'-10	68	16	2'-10	68						
6c3	VERTICAL	—	16	4'-1	98	16	4'-1	98	16	4'-1	98	16	4'-1	98	16	4'-1	98	16	4'-1	98	16	4'-1	98	16	4'-1	98						
4c4	VERTICAL HOOPS	—	20	2'-10	38	20	2'-10	38	20	2'-10	38	20	2'-10	38	20	2'-10	38	20	2'-10	38	20	2'-10	38	20	2'-10	38						
4c5	VERTICAL HOOPS	—	16	3'-1	33	16	3'-1	33	16	3'-1	33	16	3'-1	33	16	3'-1	33	16	3'-1	33	16	3'-1	33	16	3'-1	33						
6d1	HORIZONTAL	—	24	6'-8	240	24	6'-8	240	24	6'-8	240	24	6'-8	240	24	6'-8	240	24	6'-8	240	24	6'-8	240	24	6'-8	240						
6d2	HORIZONTAL	—	32	6'-9	324	32	6'-9	324	32	6'-9	324	32	6'-9	324	32	6'-9	324	32	6'-9	324	32	6'-9	324	32	6'-9	324						
6h1	LONGITUDINAL OPEN RAIL	—	24	35'-9	1289	36	28'-4	1532	36	31'-8	1712	36	35'-0	1893	36	38'-4	2073	48	32'-2	2319	48	34'-8	2499	48	37'-2	2680	60	32'-5	2921			
6j1	VERTICAL DOWELS OPEN RAIL	—	152	4'-6	1027	184	4'-7	1267	200	4'-8	1402	216	4'-9	1541	232	4'-10	1684	264	4'-11	1950	280	5'-1	2138	296	5'-2	2297	312	5'-3	2460			
4j2	HOOPS INTERIOR POSTS	—	112	4'-8	349	144	4'-8	449	160	4'-8	499	176	4'-8	549	192	4'-8	599	224	4'-8	698	240	4'-8	748	256	4'-8	798	272	4'-8	848			
4j3	HOOPS OPEN RAIL	—	212	5'-5	767	244	5'-5	883	290	5'-5	1049	316	5'-5	1143	342	5'-5	1237	394	5'-5	1426	420	5'-5	1520	446	5'-5	1614	472	5'-5	1708			
4j4	HOOPS END POSTS	—	32	6'-5	137	32	6'-5	137	32	6'-5	137	32	6'-5	137	32	6'-5	137	32	6'-5	137	32	6'-5	137	32	6'-5	137	32	6'-5	137			
4t1	WING FOOTING TIE BARS	—	16	VARIABLE	21	16	VARIABLE	21	16	VARIABLE	21	16	VARIABLE	21	16	VARIABLE	21	16	VARIABLE	21	16	VARIABLE	21	16	VARIABLE	21	16	VARIABLE	21			
(INCLUDE WITH SUPERSTRUCTURE REINFORCING)			TOTAL (LBS.)			5100			5799			6330			6794			7261			8061			8573			9057			9605		

REINFORCING QUANTITIES SHOWN ARE BASED ON 45° SKEW BID LENGTHS.

BENT BAR DETAILS

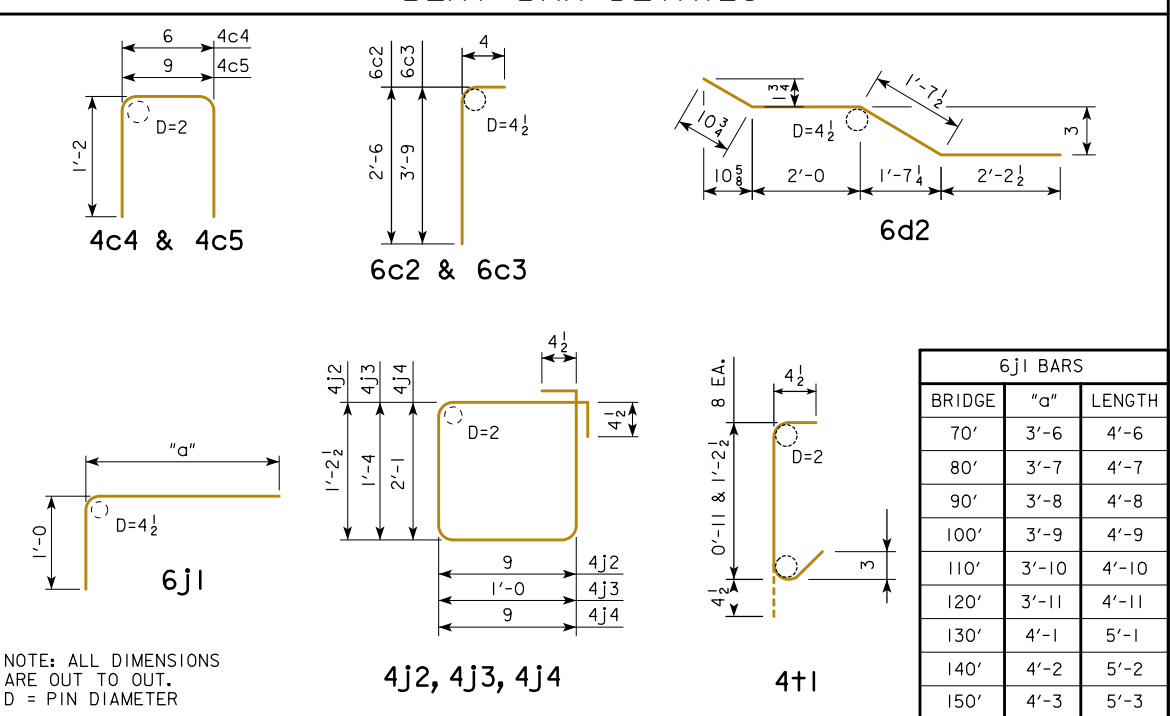

NOTE: ALL DIMENSIONS ARE OUT TO OUT. D = PIN DIAMETER

CONCRETE PLACEMENT QUANTITIES NOTE: THESE VALUES TO BE USED FOR ALL SKEWS.

BRIDGE LENGTH	70'-0	80'-0	90'-0	100'-0	110'-0	120'-0	130'-0	140'-0	150'-0
*STANDARD SECTION CU. YDS.	12.2	14.0	15.7	17.4	19.1	21.0	22.7	24.4	26.0
END SECTION 4 @ 0.687 CU. YDS.	2.8	2.8	2.8	2.8	2.8	2.8	2.8	2.8	2.8
TOTAL CU. YDS.	15.0	16.8	18.5	20.2	21.9	23.8	25.5	27.2	28.8

* CONCRETE QUANTITIES SHOWN ARE BASED ON 45° SKEW BID LENGTHS.

CONCRETE OPEN RAIL QUANTITIES

BRIDGE LENGTH		UNIT	70'-0	80'-0	90'-0	100'-0	110'-0	120'-0	130'-0	140'-0	150'-0
CONCRETE OPEN RAILING, TL-4	0° SKEW	L.F.	162.0	182.0	202.0	222.0	242.0	262.0	282.0	302.0	322.0
CONCRETE OPEN RAILING, TL-4	15° SKEW	L.F.	162.2	182.2	202.2	222.2	242.2	262.2	282.2	302.2	322.2
CONCRETE OPEN RAILING, TL-4	30° SKEW	L.F.	162.9	182.9	202.9	222.9	242.9	262.9	282.9	302.9	322.9
CONCRETE OPEN RAILING, TL-4	45° SKEW	L.F.	164.5	184.5	204.5	224.5	244.5	264.5	284.5	304.5	324.5

OPEN RAIL NOTES:

- MINIMUM CLEAR DISTANCE FROM FACE OF CONCRETE TO NEAR REINFORCING BAR IS TO BE 2" UNLESS OTHERWISE NOTED OR SHOWN.
- COST OF THE JOINT SEALER AND BOND BREAKER SHALL BE CONSIDERED INCIDENTAL TO OTHER CONSTRUCTION.
- THE CONCRETE OPEN RAIL IS TO BE BID ON A LINEAL FOOT BASIS MEASURED FROM END TO END OF RAIL. THE NUMBER OF LINEAL FEET OF OPEN RAIL INSTALLED WILL BE PAID FOR AT THE CONTRACT PRICE PER LINEAL FOOT. PRICE BID FOR "CONCRETE OPEN RAILING, TL-4" SHALL BE FULL COMPENSATION FOR FURNISHING ALL MATERIAL, EXCLUDING REINFORCING STEEL, AND ALL OF THE EQUIPMENT AND LABOR REQUIRED TO CONSTRUCT THE RAIL IN ACCORDANCE WITH THESE PLANS AND CURRENT SPECIFICATIONS.
- ALL OPEN RAIL CONCRETE IS TO BE CLASS C.
- IF PLANS SPECIFY THAT THE REINFORCING STEEL IN THE SLAB BE EPOXY COATED, ALL OPEN RAIL REINFORCING STEEL SHALL ALSO BE EPOXY COATED. OTHERWISE THE OPEN RAIL REINFORCING SHALL NOT BE EPOXY COATED.
- THE JOINT SEALER SHALL BE LIGHT GRAY NONSAG LATEX CAULKING SEALER MARKETED FOR OUTDOOR USE. NO TESTING OR CERTIFICATION IS REQUIRED.
- TOP OF THE OPEN RAIL IS TO BE PARALLEL TO THEORETICAL ∇ GRADE.
- IF CONDUIT IS REQUIRED IN THIS PLAN THE RIGID STEEL CONDUIT, JUNCTION BOXES AND FITTINGS INCLUDING LABOR AND ANY ADDITIONAL WORK TO DO THE INSTALLATION IS CONSIDERED INCIDENTAL TO THE COST OF THE RAILING.

REVIS 07-2009: NUMBER OF 6d1 & 6d2 BARS CHANGED AND IS REFLECTED IN THE WEIGHT CHANGE. REVIS 07-2016: REMOVED OPEN RAIL NOTE STATING "ALL OPEN RAIL REINFORCING STEEL IS TO BE INCLUDED WITH THE SUPERSTRUCTURE REINFORCING STEEL." REVIS 09-2020: UPDATED BRIDGE ENGINEER SIGNATURE.

09-2020 LATEST REVISION DATE	 APPROVED BY BRIDGE ENGINEER	STANDARD DESIGN - 30' ROADWAY, 3 SPAN BRIDGES CONTINUOUS CONCRETE SLAB BRIDGES NOVEMBER, 2006	
		OPEN RAIL DETAILS (TL-4)	J30-44-06

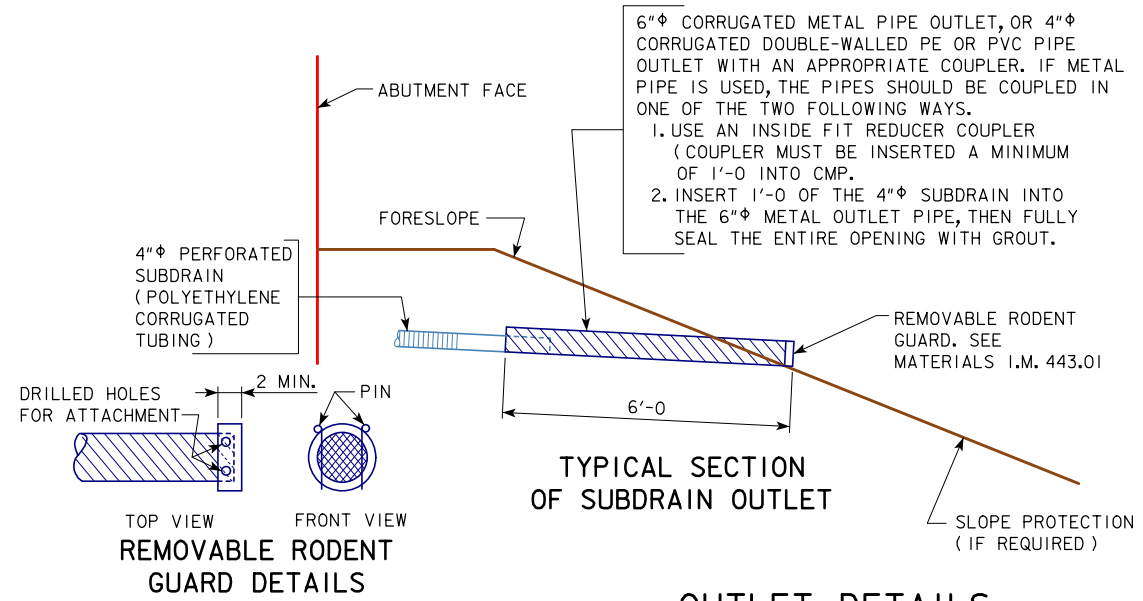

OUTLET DETAILS

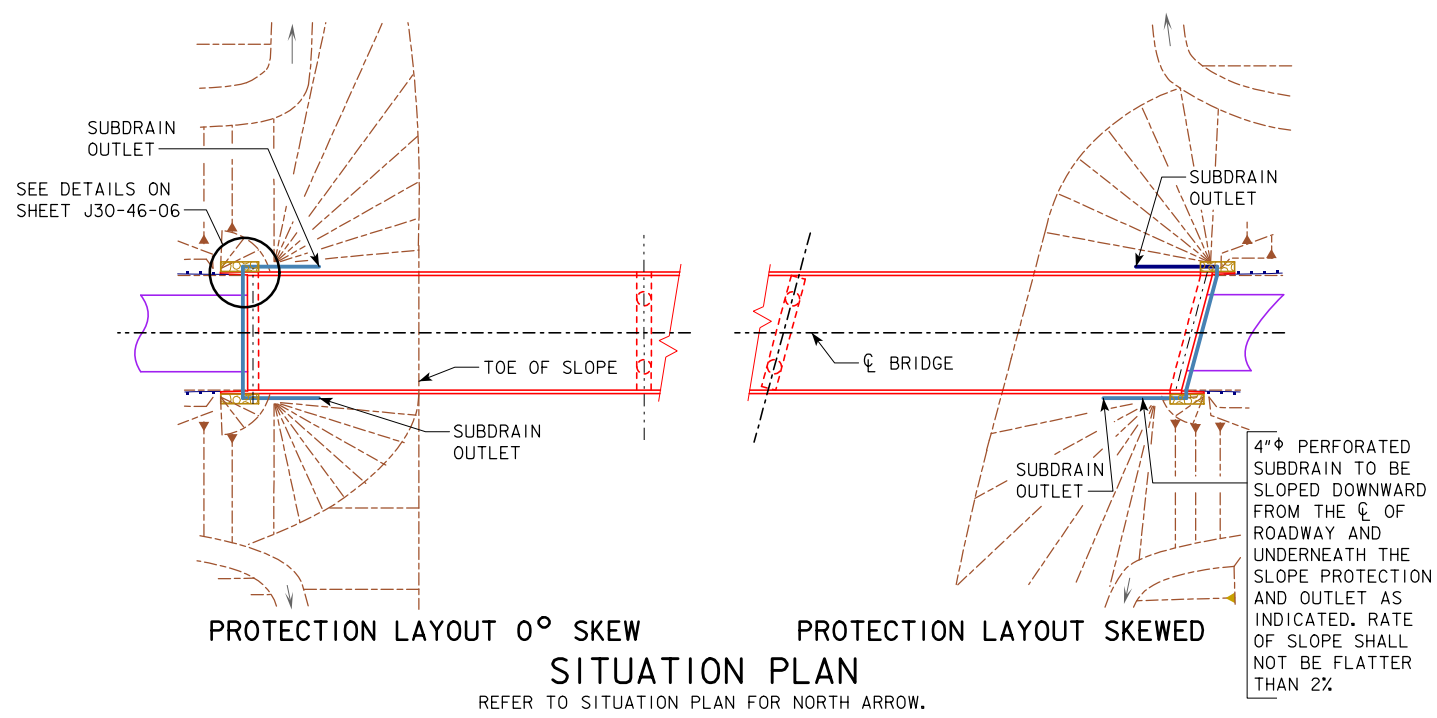

REVISED 12-2008: REMOVED GRANULAR BACKFILL DETAILS.
REVISED 09-2020: UPDATED BRIDGE ENGINEER SIGNATURE.

09-2020 LATEST REVISION DATE	 APPROVED BY BRIDGE ENGINEER		
		STANDARD DESIGN - 30' ROADWAY, 3 SPAN BRIDGES CONTINUOUS CONCRETE SLAB BRIDGES NOVEMBER, 2006	
		SUBDRAIN DETAILS	J30-45-06

REVISED 09-2014: THE AREA OF MACADAM STONE WAS EXTENDED 2'-0" IN FRONT OF THE BRIDGE WING.
REVISED 09-2020: UPDATED BRIDGE ENGINEER SIGNATURE.

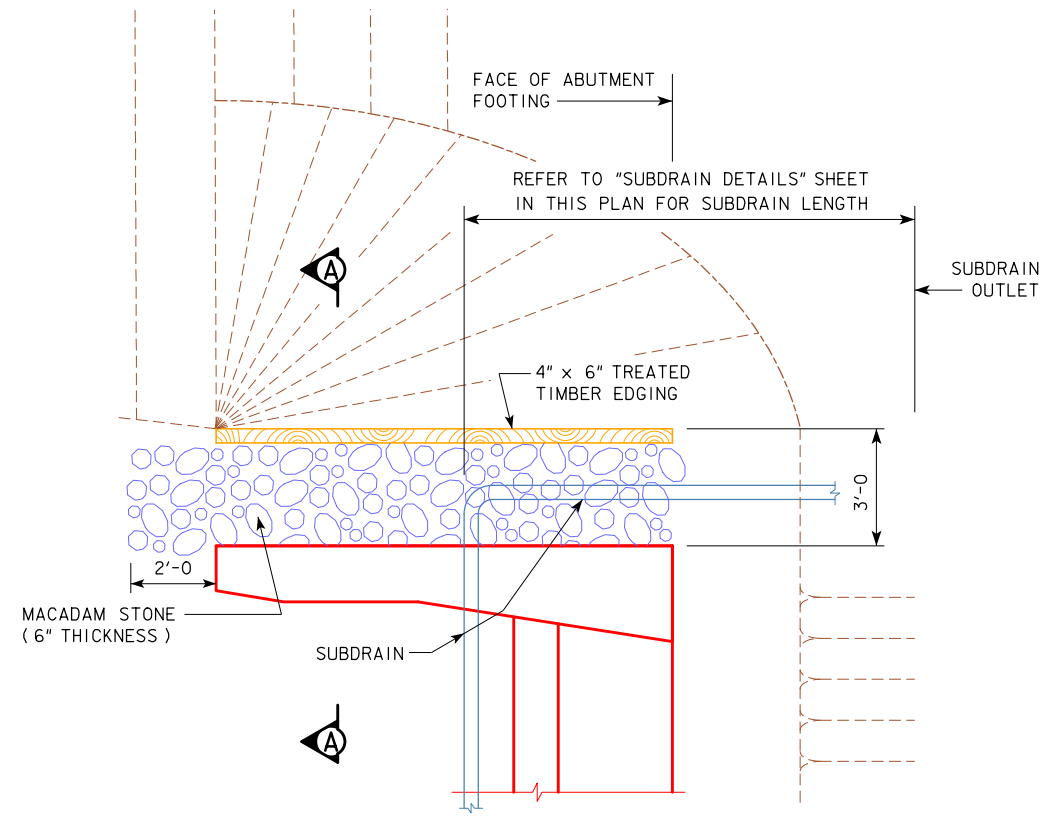

TOP VIEW OF WING ARMORING

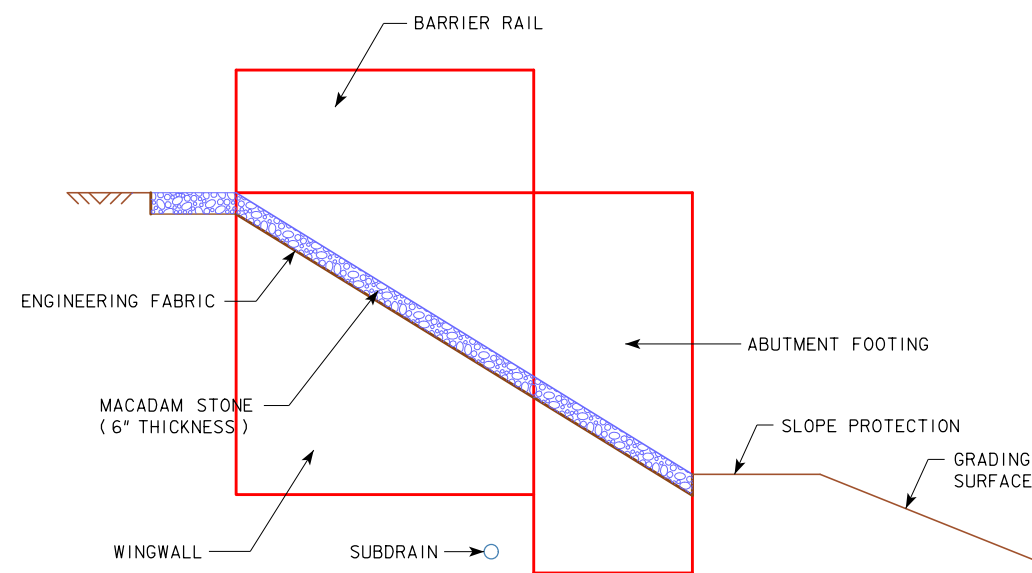

PROFILE VIEW OF WING ARMORING

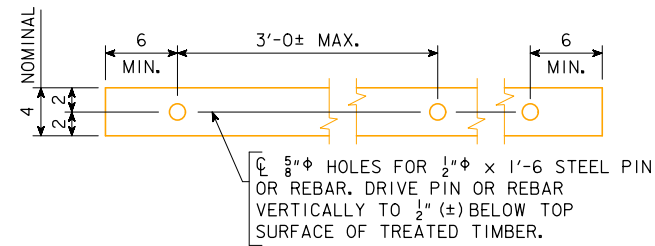

4" x 6" TREATED TIMBER EDGING DETAILS

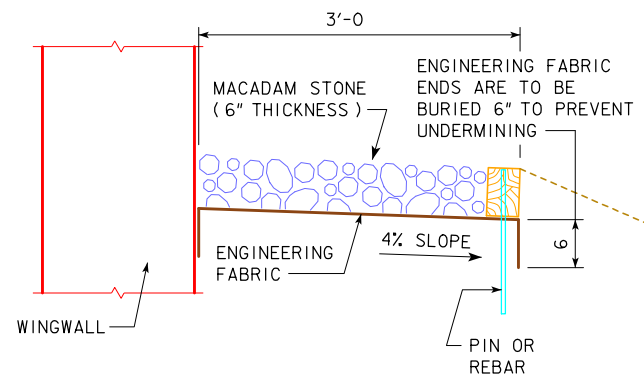

SECTION A-A

SUBDRAIN NOTES:

SEE J30-45-06 AND "SITUATION PLAN" SHEETS FOR DETAILS OF PLACING ALL SUBDRAINS AND SUBDRAIN OUTLETS REQUIRED FOR THIS STRUCTURE.

THE BRIDGE CONTRACTOR IS TO INSTALL SUBDRAINS BEHIND THE ABUTMENT. THE SUBDRAINS SHALL BE 4" IN DIAMETER AND BE IN ACCORDANCE WITH ARTICLE 4143.01, B, OF THE STANDARD SPECIFICATIONS. THE SUBDRAIN OUTLET SHALL CONSIST OF A 6'-0" LENGTH OF PIPE WITH A REMOVABLE RODENT GUARD.

THE DIMENSIONS SHOWN FOR THE PROPOSED SUBDRAINS ARE BASED ON THE PROPOSED GRADING LAYOUT OF BRIDGE BERMS. THE DIMENSIONS SHOWN ARE FOR ESTIMATING ONLY. REQUIRED LENGTHS AND GENERAL LOCATIONS OF SUBDRAINS ARE SUBJECT TO CHANGE DUE TO FIELD ADJUSTMENTS OF THE GRADING LAYOUT.

THE COST OF FURNISHING AND PLACING SUBDRAIN (INCLUDING EXCAVATION), GRANULAR BACKFILL, POROUS BACKFILL, AND SUBDRAIN OUTLET IS TO BE INCLUDED IN THE PRICE BID FOR "STRUCTURAL CONCRETE (BRIDGE)". NO EXTRA PAYMENT WILL BE MADE.

MACADAM STONE WING ARMORING NOTES:

MACADAM STONE SHALL BE PLACED ALONG THE SIDE OF THE WING AND ABUTMENT FOOTING. THIS IS TYPICAL AT EACH CORNER OF THE BRIDGE UNLESS OTHERWISE NOTED IN THE PLANS. THE MACADAM STONE AT THESE LOCATIONS SHALL BE UNDERLAYED WITH ENGINEERING FABRIC AND BE IN ACCORDANCE WITH ARTICLE 4196.01, B, 3, OF THE STANDARD SPECIFICATIONS.

THE BRIDGE BERM FORESLOPE SHALL BE COMPACTED AND SHAPED AS SHOWN ON THESE PLANS, THE SITUATION PLAN AND AS DIRECTED BY THE ENGINEER. THE BERM FORESLOPE SHALL BE FIRM WHEN THE ENGINEERING FABRIC AND MACADAM STONE ARE PLACED.

THE ENGINEERING FABRIC SHALL BE IN ACCORDANCE WITH ARTICLE 4196.01, B, 3, OF THE STANDARD SPECIFICATIONS. IF THE ENGINEERING FABRIC IS LAPPED THE LAPS SHALL BE A MINIMUM OF ONE FOOT IN LENGTH, SHINGLE FASHION WITH UP SLOPE LAP PIECE ON TOP AND STAPLED FOR CONTINUITY.

THE MACADAM STONE SHALL BE IN ACCORDANCE WITH ARTICLE 4122.02, OF THE STANDARD SPECIFICATIONS FOR COARSE MATERIAL (NO CHOKE STONE IS ALLOWED).

WOOD PRESERVATIVE TREATMENT FOR THE TIMBER EDGING SHALL MEET THE REQUIREMENTS FOR GUARDRAIL POSTS, SAWED FOUR SIDES, AND BE IN ACCORDANCE WITH SECTION 4161, OF THE STANDARD SPECIFICATIONS.

THE MACADAM STONE SHALL BE DEPOSITED, SPREAD, CONSOLIDATED AND SHAPED BY MECHANICAL OR HAND METHODS THAT WILL PROVIDE UNIFORM DEPTH AND DENSITY AND PROVIDE UNIFORM SURFACE APPEARANCE.

PAYMENT FOR THE BRIDGE WING ARMORING SHALL BE INCIDENTAL TO THE BID ITEM "STRUCTURAL CONCRETE (BRIDGE)" AND SHALL INCLUDE COSTS OF ALL MATERIAL AND LABOR TO CONSTRUCT THE WING ARMORING AS SHOWN ON THESE PLANS.

09-2020 LATEST REVISION DATE APPROVED BY BRIDGE ENGINEER		
	STANDARD DESIGN - 30' ROADWAY, 3 SPAN BRIDGES CONTINUOUS CONCRETE SLAB BRIDGES NOVEMBER, 2006	
	WING ARMORING DETAILS	J30-46-06

REVISED 09-2014: THE TECHNICAL DATA INFORMATION TABLE WAS REMOVED AND A NOTE ADDED TO REFER TO THE STANDARDS SPECIFICATIONS FOR THIS INFORMATION.
 REVISED 07-2016: CHANGED THE BRIDGE APPROACH PAVEMENT STANDARD TO "BR" (WAS "RK").
 REVISED 09-2020: UPDATED BRIDGE ENGINEER SIGNATURE.

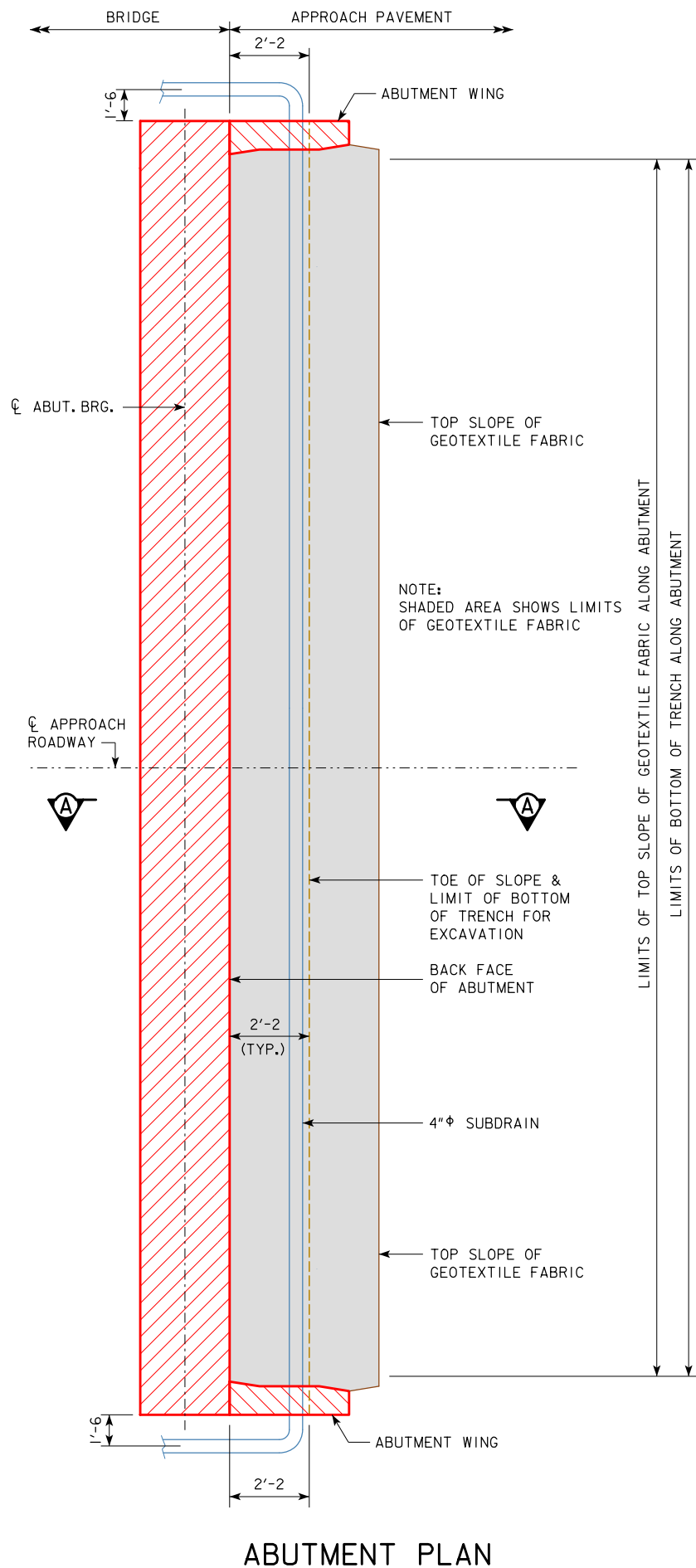

ABUTMENT BACKFILL PROCESS:

THE BASE OF THE EXCAVATION SUBGRADE BEHIND THE ABUTMENT IS TO BE GRADED WITH A 4% SLOPE AWAY FROM THE ABUTMENT FOOTING AND A 2% CROSS SLOPE IN THE DIRECTION OF THE SUBDRAIN OUTLET. THIS EXCAVATION SHAPING IS TO BE DONE PRIOR TO BEGINNING INSTALLATION OF THE GEOTEXTILE AND BACKFILL MATERIAL.

AFTER THE SUBGRADE HAS BEEN SHAPED, THE GEOTEXTILE FABRIC SHALL BE INSTALLED IN ACCORDANCE WITH THE DETAILS SHOWN. THE FABRIC IS INTENDED TO BE INSTALLED IN THE BASE OF THE EXCAVATION AND EXTENDED VERTICALLY UP THE ABUTMENT BACKWALL, ABUTMENT WING WALLS, AND EXCAVATION FACE TO A HEIGHT THAT WILL BE APPROXIMATELY 1 TO 2 FOOT HIGHER THAN THE HEIGHT OF THE POROUS BACKFILL PLACEMENT AS SHOWN IN THE "BACKFILL DETAILS" ON THIS SHEET. THE STRIPS OF THE FABRIC PLACED SHALL OVERLAP APPROXIMATELY 1 FOOT AND SHALL BE PINNED IN PLACE. THE FABRIC SHALL BE ATTACHED TO THE ABUTMENT BY USING LATH FOLDED IN THE FABRIC AND SECURED TO THE CONCRETE WITH SHALLOW CONCRETE NAILS. THE FABRIC PLACED AGAINST THE EXCAVATION FACE SHALL BE PINNED.

WHEN THE FABRIC IS IN PLACE, THE SUBDRAIN SHALL BE INSTALLED DIRECTLY ON THE FABRIC AT THE TOE OF THE REAR EXCAVATION SLOPE. A SLOT WILL NEED TO BE CUT IN THE FABRIC AT THE POINT WHERE THE SUBDRAIN EXITS THE FABRIC NEAR THE END OF THE ABUTMENT WING WALL.

POROUS BACKFILL IS THEN PLACED AND LEVELED, NO COMPACTION IS REQUIRED.

THE REMAINING WORK INVOLVES BACKFILLING WITH FLOODABLE BACKFILL, SURFACE FLOODING, AND VIBRATORY COMPACTION. THE FLOODABLE BACKFILL MATERIAL SHALL BE IN ACCORDANCE WITH THE STANDARD SPECIFICATIONS. THE FLOODABLE BACKFILL SHALL BE PLACED IN INDIVIDUAL LIFTS, SURFACE FLOODED, AND COMPACTED WITH VIBRATORY COMPACTION TO ENSURE FULL CONSOLIDATION. LIMIT THE LOOSE LIFTS TO NO MORE THAN 2 FEET OF THICKNESS.

START SURFACE FLOODING FOR EACH FLOODABLE BACKFILL LIFT AT THE HIGH POINT OF THE SUBDRAIN AND PROGRESS TO THE LOW POINT WHERE THE SUBDRAIN EXITS THE FABRIC. TO ENSURE UNIFORM SURFACE FLOODING, WATER RUNNING FULL IN A 2-INCH DIAMETER HOSE SHOULD BE SPRAYED IN SUCCESSIVE 6-FOOT TO 8-FOOT INCREMENTS FOR 5 MINUTES WITHIN EACH INCREMENT.

FLOODABLE BACKFILL LIFT PLACEMENT, FLOODING, AND COMPACTION SHALL PROGRESS UNTIL THE REQUIRED FULL THICKNESS OF THE ABUTMENT BACKFILL HAS BEEN COMPLETED.

WATER REQUIRED FOR FLOODING, SUBDRAINS, POROUS BACKFILL, FLOODABLE BACKFILL, AND GEOTEXTILE FABRIC FURNISHED AT THE BRIDGE ABUTMENTS WILL NOT BE MEASURED SEPARATELY FOR PAYMENT.

THE COST OF WATER REQUIRED FOR FLOODING, SUBDRAINS, POROUS BACKFILL, FLOODABLE BACKFILL, AND GEOTEXTILE FABRIC FURNISHED AT THE BRIDGE ABUTMENTS SHALL BE INCLUDED IN THE CONTRACT UNIT PRICE BID FOR STRUCTURAL CONCRETE.

NOTE:
SEE SUBDRAIN DETAILS SHEET FOR DETAILS NOT SHOWN ON THIS SHEET WHICH ARE PERTINENT TO THIS STRUCTURE.

NOTE:

SUBDRAIN SHALL SLOPE DOWNWARD 2% FROM CL APPROACH ROADWAY WHEN OUTLETTING BOTH SIDES OF THE ABUTMENT.

SUBDRAIN SHALL SLOPE DOWNWARD 2% FROM HIGH END WHEN OUTLETTING AT ONE END OF THE ABUTMENT.

THE GEOTEXTILE FABRIC SHALL BE IN ACCORDANCE WITH ARTICLE 4196.01, B, 6 OF THE STANDARD SPECIFICATIONS. IF THE ENGINEERING FABRIC IS LAPPED THE LAPS SHALL BE A MINIMUM OF ONE FOOT IN LENGTH, SHINGLE FASHION WITH UP SLOPE LAP PIECE ON TOP AND STAPLED FOR CONTINUITY.

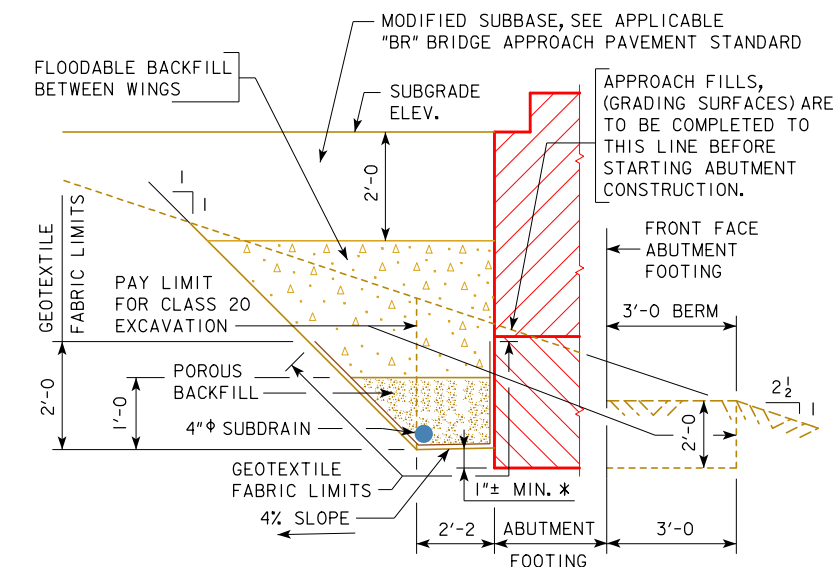

09-2020 LATEST REVISION DATE APPROVED BY BRIDGE ENGINEER		
	STANDARD DESIGN - 30' ROADWAY, 3 SPAN BRIDGES CONTINUOUS CONCRETE SLAB BRIDGES DECEMBER, 2008	
	ABUTMENT BACKFILL DETAILS FOR 0° SKEWS	J30-47-06

REVISED 09-2014: THE TECHNICAL DATA INFORMATION TABLE WAS REMOVED AND A NOTE ADDED TO REFER TO THE STANDARDS SPECIFICATIONS FOR THIS INFORMATION.
 REVISED 07-2016: CHANGED THE BRIDGE APPROACH PAVEMENT STANDARD TO "BR" (WAS "RK").
 REVISED 09-2020: UPDATED BRIDGE ENGINEER SIGNATURE.

"W" DIMENSION	
SKEW	DIMENSION
15°	2'-2 $\frac{7}{8}$
30°	2'-6
45°	3'-0 $\frac{3}{4}$

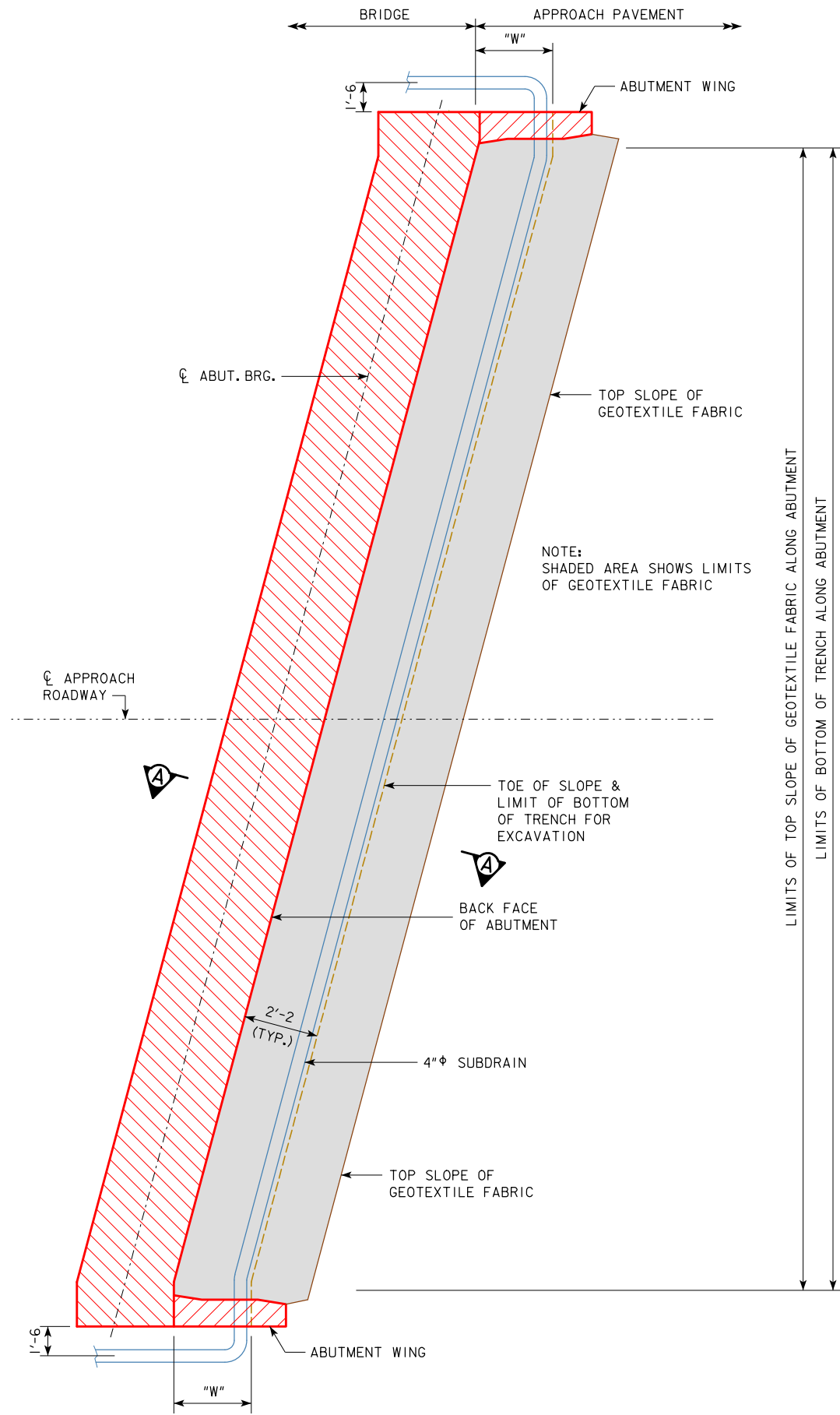

ABUTMENT PLAN WITHOUT WING EXTENSIONS

ABUTMENT BACKFILL PROCESS:

THE BASE OF THE EXCAVATION SUBGRADE BEHIND THE ABUTMENT IS TO BE GRADED WITH A 4% SLOPE AWAY FROM THE ABUTMENT FOOTING AND A 2% CROSS SLOPE IN THE DIRECTION OF THE SUBDRAIN OUTLET. THIS EXCAVATION SHAPING IS TO BE DONE PRIOR TO BEGINNING INSTALLATION OF THE GEOTEXTILE AND BACKFILL MATERIAL.

AFTER THE SUBGRADE HAS BEEN SHAPED, THE GEOTEXTILE FABRIC SHALL BE INSTALLED IN ACCORDANCE WITH THE DETAILS SHOWN. THE FABRIC IS INTENDED TO BE INSTALLED IN THE BASE OF THE EXCAVATION AND EXTENDED VERTICALLY UP THE ABUTMENT BACKWALL, ABUTMENT WING WALLS, AND EXCAVATION FACE TO A HEIGHT THAT WILL BE APPROXIMATELY 1 TO 2 FOOT HIGHER THAN THE HEIGHT OF THE POROUS BACKFILL PLACEMENT AS SHOWN IN THE "BACKFILL DETAILS" ON THIS SHEET. THE STRIPS OF THE FABRIC PLACED SHALL OVERLAP APPROXIMATELY 1 FOOT AND SHALL BE PINNED IN PLACE. THE FABRIC SHALL BE ATTACHED TO THE ABUTMENT BY USING LATH FOLDED IN THE FABRIC AND SECURED TO THE CONCRETE WITH SHALLOW CONCRETE NAILS. THE FABRIC PLACED AGAINST THE EXCAVATION FACE SHALL BE PINNED.

WHEN THE FABRIC IS IN PLACE, THE SUBDRAIN SHALL BE INSTALLED DIRECTLY ON THE FABRIC AT THE TOE OF THE REAR EXCAVATION SLOPE. A SLOT WILL NEED TO BE CUT IN THE FABRIC AT THE POINT WHERE THE SUBDRAIN EXITS THE FABRIC NEAR THE END OF THE ABUTMENT WING WALL.

POROUS BACKFILL IS THEN PLACED AND LEVELED, NO COMPACTION IS REQUIRED.

THE REMAINING WORK INVOLVES BACKFILLING WITH FLOODABLE BACKFILL, SURFACE FLOODING, AND VIBRATORY COMPACTION. THE FLOODABLE BACKFILL MATERIAL SHALL BE IN ACCORDANCE WITH THE STANDARD SPECIFICATIONS. THE FLOODABLE BACKFILL SHALL BE PLACED IN INDIVIDUAL LIFTS, SURFACE FLOODED, AND COMPACTED WITH VIBRATORY COMPACTION TO ENSURE FULL CONSOLIDATION. LIMIT THE LOOSE LIFTS TO NO MORE THAN 2 FEET OF THICKNESS.

START SURFACE FLOODING FOR EACH FLOODABLE BACKFILL LIFT AT THE HIGH POINT OF THE SUBDRAIN AND PROGRESS TO THE LOW POINT WHERE THE SUBDRAIN EXITS THE FABRIC. TO ENSURE UNIFORM SURFACE FLOODING, WATER RUNNING FULL IN A 2-INCH DIAMETER HOSE SHOULD BE SPRAYED IN SUCCESSIVE 6-FOOT TO 8-FOOT INCREMENTS FOR 5 MINUTES WITHIN EACH INCREMENT.

FLOODABLE BACKFILL LIFT PLACEMENT, FLOODING, AND COMPACTION SHALL PROGRESS UNTIL THE REQUIRED FULL THICKNESS OF THE ABUTMENT BACKFILL HAS BEEN COMPLETED.

WATER REQUIRED FOR FLOODING, SUBDRAINS, POROUS BACKFILL, FLOODABLE BACKFILL, AND GEOTEXTILE FABRIC FURNISHED AT THE BRIDGE ABUTMENTS WILL NOT BE MEASURED SEPARATELY FOR PAYMENT.

THE COST OF WATER REQUIRED FOR FLOODING, SUBDRAINS, POROUS BACKFILL, FLOODABLE BACKFILL, AND GEOTEXTILE FABRIC FURNISHED AT THE BRIDGE ABUTMENTS SHALL BE INCLUDED IN THE CONTRACT UNIT PRICE BID FOR STRUCTURAL CONCRETE.

NOTE:
 SEE SUBDRAIN DETAILS SHEET FOR DETAILS NOT SHOWN ON THIS SHEET WHICH ARE PERTINENT TO THIS STRUCTURE.

NOTE:

SUBDRAIN SHALL SLOPE DOWNWARD 2% FROM CL APPROACH ROADWAY WHEN OUTLETTING BOTH SIDES OF THE ABUTMENT.

SUBDRAIN SHALL SLOPE DOWNWARD 2% FROM HIGH END WHEN OUTLETTING AT ONE END OF THE ABUTMENT.

THE GEOTEXTILE FABRIC SHALL BE IN ACCORDANCE WITH ARTICLE 4196.01, B, 6 OF THE STANDARD SPECIFICATIONS. IF THE ENGINEERING FABRIC IS LAPPED THE LAPS SHALL BE A MINIMUM OF ONE FOOT IN LENGTH, SHINGLE FASHION WITH UP SLOPE LAP PIECE ON TOP AND STAPLED FOR CONTINUITY.

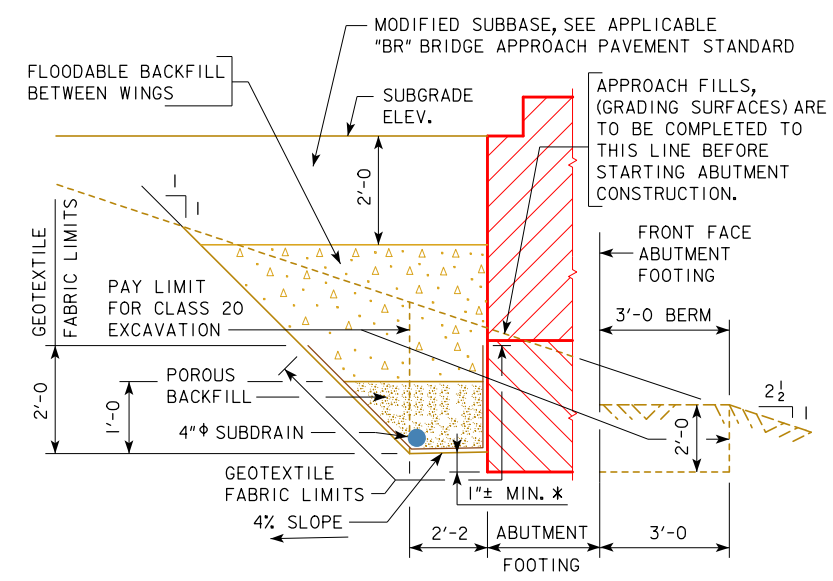

SECTION A-A
 BACKFILL DETAILS

NOTE: GEOTEXTILE FABRIC WILL BE ATTACHED TO FACE OF ABUTMENT FOOTING AND WINGS.

* DIMENSION VARIES DUE TO 2% SUBDRAIN SLOPE.

09-2020 LATEST REVISION DATE APPROVED BY BRIDGE ENGINEER		
	STANDARD DESIGN - 30' ROADWAY, 3 SPAN BRIDGES CONTINUOUS CONCRETE SLAB BRIDGES DECEMBER, 2008	
	ABUTMENT BACKFILL DETAILS FOR 15°, 30°, & 45° SKEWS	J30-48-06