

DESIGNER INFORMATION

Refer to Materials I.M. 455.02 for a list of approved sources.

Use materials meeting the respective manufacturer's specifications. Install end terminals according to the manufacturer's recommendations.

Drive posts using a hammer driver. Ensure posts are not damaged during installation. Posts may be placed in prebored holes if site conditions are such that posts cannot be driven. Place backfill material consisting of material removed or other suitable soil around posts. Place the backfill material in lifts not exceeding 4 inches. Thoroughly compact each lift before the next lift is placed.

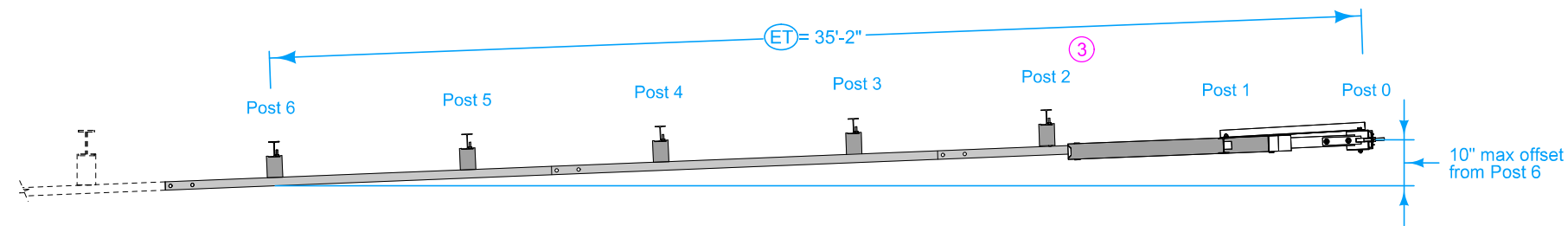

PLAN

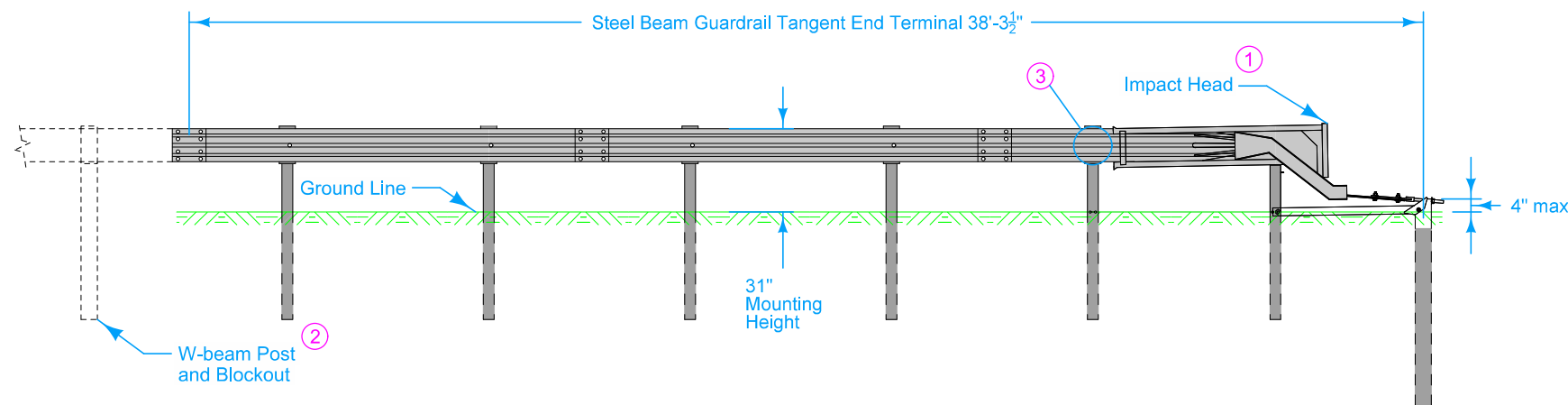

ELEVATION

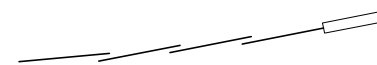

← NEAREST TRAFFIC

LAPPING PROCEDURE

- ① Cover entire face of impact head with alternating black and yellow striped adhesive sheeting meeting the following requirements:
 - Stripes are approximately 3 inches wide and slope down at a 45 degree angle toward the side on which traffic is to pass the end terminal.
 - Yellow stripes meet the retroreflectivity requirements for Type III or Type IV reflective sheeting.
- ② Refer to BA-200.
- ③ Bolt only the blockout to the post. Do not bolt the rail to the post.

Possible Contract Item:
Steel Beam Guardrail Tangent End Terminal, BA-225

Possible Tabulation:
108-8A

	REVISION	
	4	10-17-23
STANDARD ROAD PLAN		BA-225
		SHEET 1 of 1

REVISIONS: Added note 3. Do not bolt rail to post #2 per manufactures instructions.

APPROVED BY DESIGN METHODS ENGINEER

**STEEL BEAM GUARDRAIL
 TANGENT END TERMINAL
 (MASH TL-2)**