

DESIGNER INFORMATION

Install aprons and hardware fabricated from galvanized steel complying with Section 4141 of the Standard Specifications. Alternate design details may be submitted to the Engineer for approval.

Comply with the following:

1. All 3 piece bodies are to have 12-gage sides and 10-gage center panels. Multiple panel bodies are to have lap seams which are to be tightly joined by galvanized rivets or bolts.
2. For the 77"x52" and 83"x57" sizes, the reinforced edge is to be supplemented by galvanized angles. The angles are to be attached by galvanized nuts and bolts.
3. Angle reinforcement is to be placed under the center panel seams on the 77"x52" and 83"x57" sizes.
4. Galvanized Toe plate is to be available as an accessory when specified on the order and is to be the same gage as the end section.

Aprons may be attached to culvert pipe as follows:

- A. If culvert is of circumferential corrugation, use an approved bolt or clamp to fasten apron directly to culvert.
- B. If culvert is of helical corrugation type:
 1. Use an approved sizing ring securely fastened to inside diameter of apron to connect to the culvert pipe using a special dimple band connector.
 2. "Dimple" bands are not allowed when a positive joint is specified.

Refer to Materials I.M. 441 for approved coupling devices.

Repair, to the Engineer's satisfaction, breaks or damage to the coating that occur during handling or installation.

Price bid for "Aprons, Metal, Arch" is full compension for fabrication and installation of metal arch aprons as indicated hereon.

Possible Contract Items:
Aprons, Metal, Arch

Possible Tabulations:
104-3

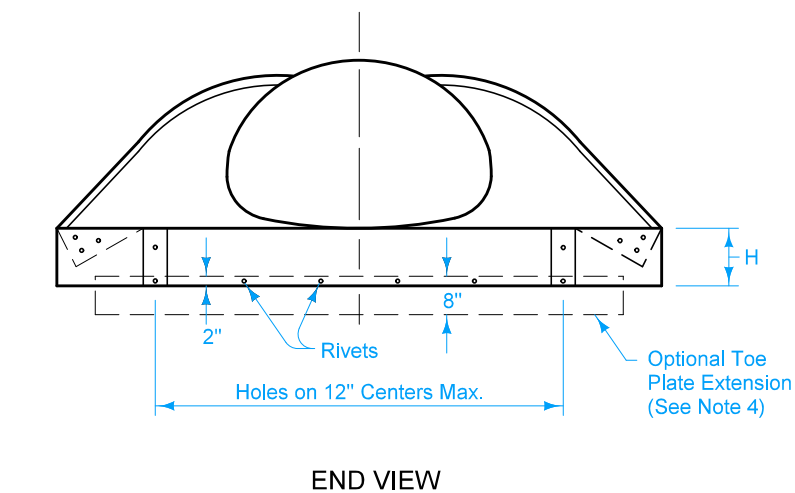
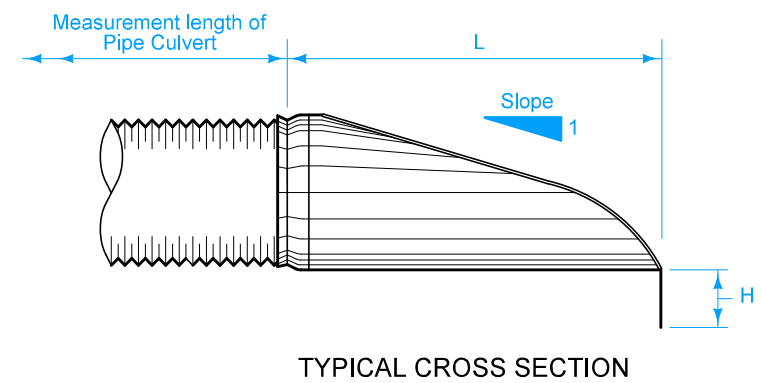
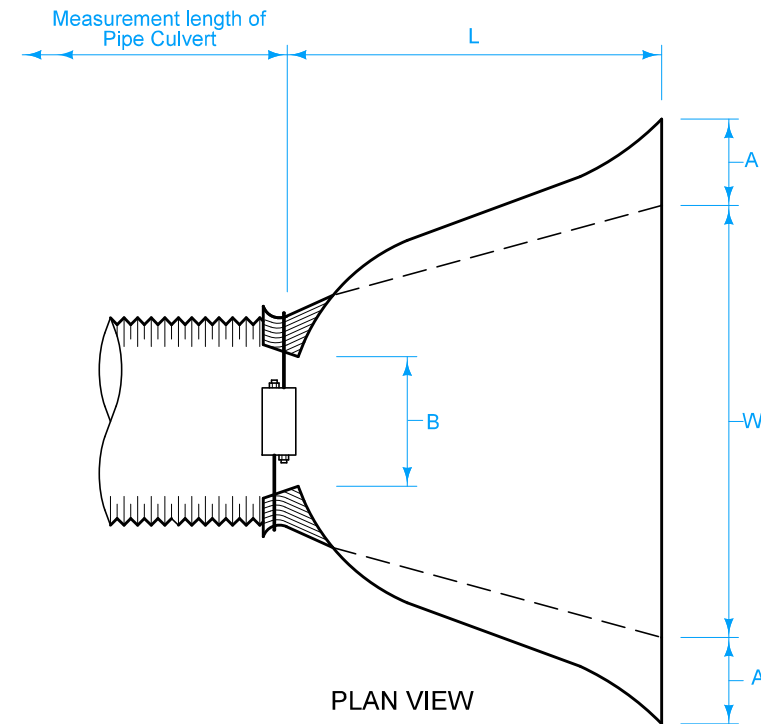

SPAN/ RISE	EQUIV. DIA.	GAGE	DIMENSIONS (In Inches)					APPROX. SLOPE
			A (±1")	B (Max.)	H (±1")	L (±1½")	W (±2")	
17"x 13"	15"	16	6½	8½-9	6	20	30	2½
21"x 15"	18"	16	7½	11	6	24	36	2½
24"x 18"	21"	16	8	12	6	28	42	2½
28"x 20"	24"	16	8	16	6	32	48	2½
35"x 24"	30"	14	10	16	7	39	60	2½
42"x 29"	36"	14	12	18	7½-8	46	75	2½
49"x 33"	42"	12	13½	21	9	53	84	2½
57"x 38"	48"	12	18½	26	12	62	90	2½
64"x 43"	54"	12	18	30	12	69	102	2¼-2
71"x 47"	60"	12/10	18½	36	12	77	114	2¼-1½
77"x 52"	66"	12/10	18	36	12	77	126	2-1½
83"x 57"	72"	12/10	18	44	12	77	135±3	2-1½

 STANDARD ROAD PLAN	REVISION	
	2	04-21-20
		DR-204
		SHEET 1 of 1

REVISIONS: Added Designer Info button.

Shawn Miller
APPROVED BY DESIGN METHODS ENGINEER

**METAL ARCH APRONS
(FOR CORRUGATED METAL PIPE)**