

**STANDARD SUBDRAIN OUTLET
TYPE A**
For existing subdrain pipes 12" or less in diameter. ⁵

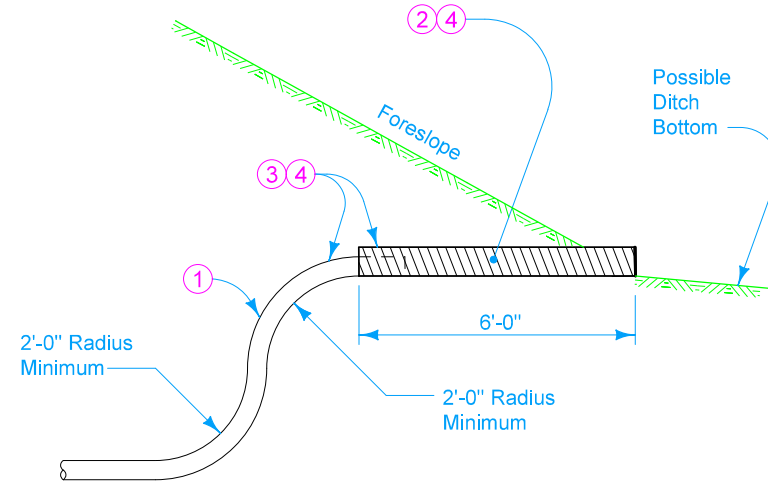

**PRESSURE RELEASE OUTLET
TYPE B**

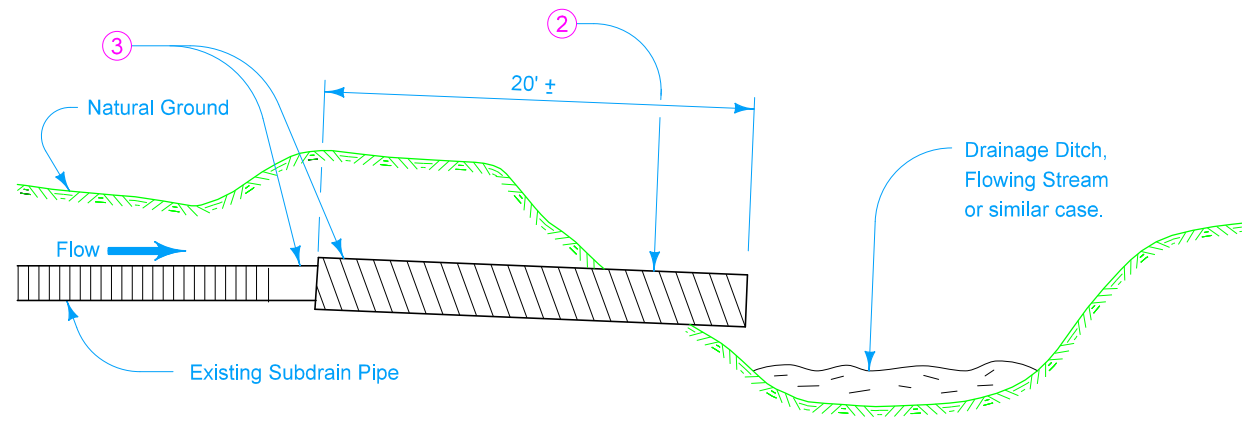

**SPECIAL OUTLET
TYPE C**

- 1 Perforated Subdrain (Polyethylene Corrugated Tubing).
- 2 If corrugated metal pipe is used, an outlet 2 inches larger than existing subdrain pipe is required. If double-walled PE or PVC pipe is used, an outlet pipe of the same diameter as the existing subdrain pipe may be used.
- 3 The pipes should be coupled in one of the two following ways: (1) Use an inside fit reducer coupler (coupler must be inserted a minimum of 12 inches into C.M.P.); or (2) Insert 12 inches of the existing subdrain pipe into the corrugated metal outlet pipe, then fully seal the entire opening with grout.
- 4 If a concrete headwall is used, refer to DR-306.
- 5 For existing subdrain pipes larger than 12 inches in diameter, use Special Outlet, Type C.

Possible Contract Item:
Subdrain Outlet (DR-305)

Possible Tabulations:
104-5C
104-6

 STANDARD ROAD PLAN	REVISION	
	2	04-19-22
	DR-305	
SHEET 1 of 1		

REVISIONS: Added 104-6 to Possible Tabulations.

Steve Miller
APPROVED BY DESIGN METHODS ENGINEER

**SUBDRAIN OUTLETS
(STANDARD SUBDRAIN,
PRESSURE RELEASE AND SPECIAL)**