

ONE LANE WIDTH PATCH

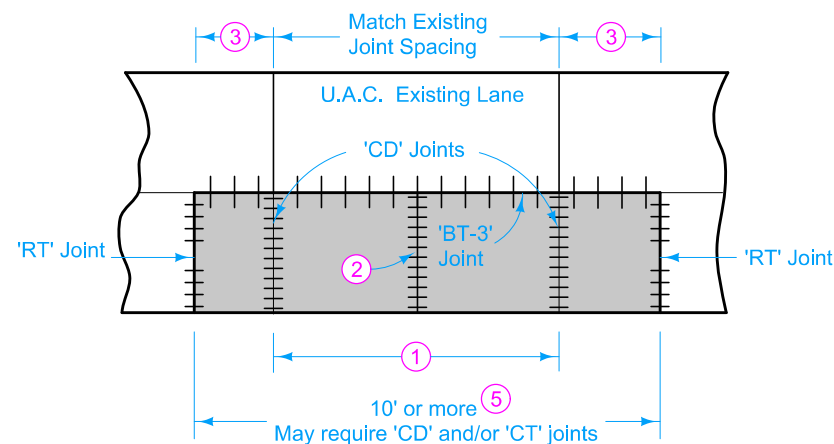

ONE LANE WIDTH PATCH

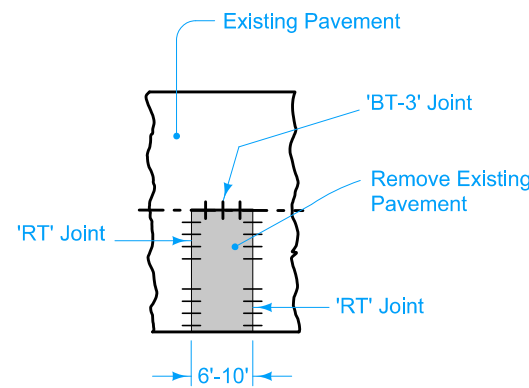

ONE LANE PATCH (NO OPPOSING JOINT)

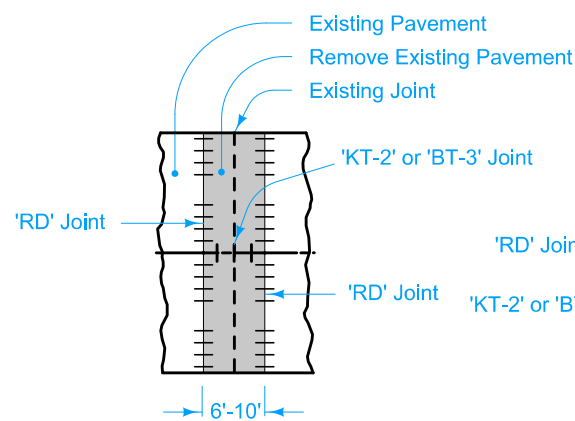

FULL ROADWAY WIDTH PATCH

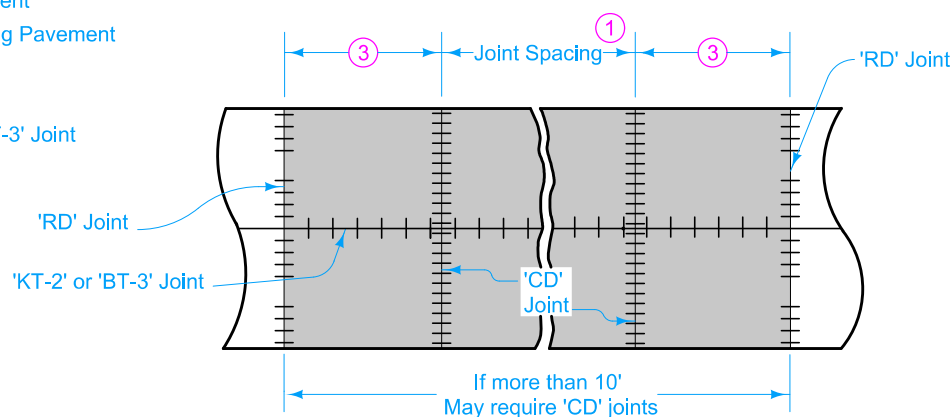

FULL ROADWAY WIDTH PATCH

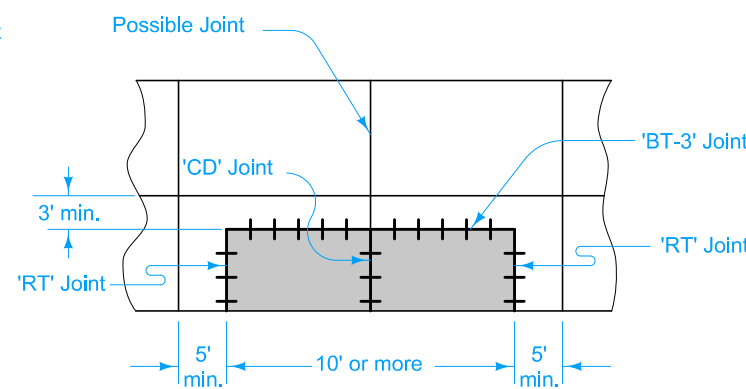

PARTIAL LANE WIDTH PATCH

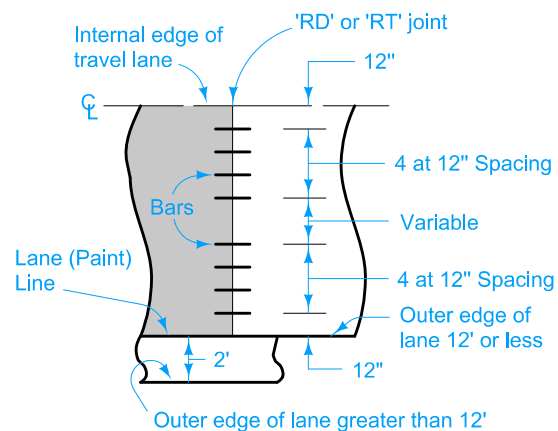

DETAIL FOR 'RT' OR 'RD' JOINT BAR SPACING

TYPICAL HALF PLAN

For interior lanes, place first bar 12" from edge of lane (slab).

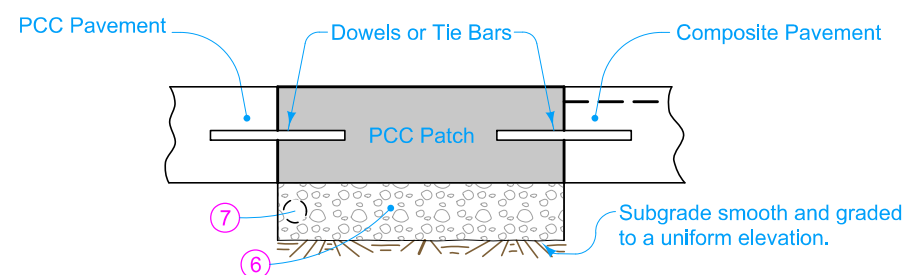

LONGITUDINAL SECTION THRU PATCH

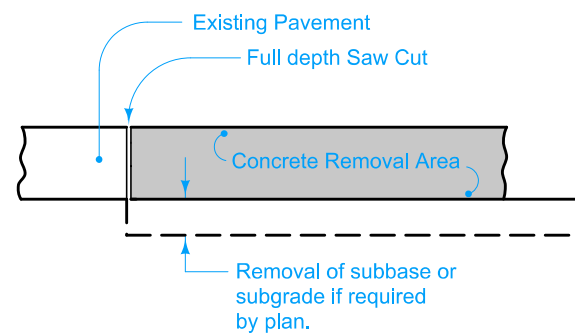

PAVEMENT REMOVAL DETAILS

BAR SIZE TABLE			
Existing PCC Pavement Thickness	Less than 8"	8" to 10"	More than 10"
DOWEL SIZE	3/4"	1 1/4"	1 1/2"
TIE BAR SIZE	#6	#10	#11

See **PV-101** for joint and bar placement details.

Construct rectangular patches even when existing pavement joints are skewed.

- ① Joint spacing 10 feet minimum, 17 feet maximum, 15 feet optimum.
- ② If there is no existing joint or crack in the adjacent pavement, place a 'CT' joint. If there is an existing joint or crack in the adjacent pavement, place a 'CD' joint at the same transverse location. Saw but do not seal 'CT' joints.
- ③ New 'CD' joint must be a minimum 5 feet from the patch end.
- ④ Do not saw or seal the joint. Place 1/2 inch preformed joint material between patch and concrete in adjacent lane.
- ⑤ If one lane patch exceeds 50 feet, both lanes should be considered for patching.
- ⑥ Possible Subbase Patch, see **PR-140**.
- ⑦ If longitudinal subdrain (shoulder) is not to be placed or if it is not present on side of roadway to be patched, then place drain per **PR-140**.

Possible Contract Items:

- CD Joint Assembly
- CT Joint
- Patches by Count (Repair)
- Patches, Full-Depth Finish, by Area
- Patches, Full-Depth Finish, by Count
- Patches, Full Depth Finish, by Area (50 feet in length or greater)
- Patches, Full-Depth Repair

Possible Tabulation:

102-6C

	REVISION	
	2	04-21-20
STANDARD ROAD PLAN		PR-103
		SHEET 1 of 1
REVISIONS: Removed INTERIM from the standard.		
 APPROVED BY DESIGN METHODS ENGINEER		
FULL DEPTH PCC PATCH WITH DOWELS		