

SIGN INSTALLATION
Side View

STUB & SIGN POSTS
3d View

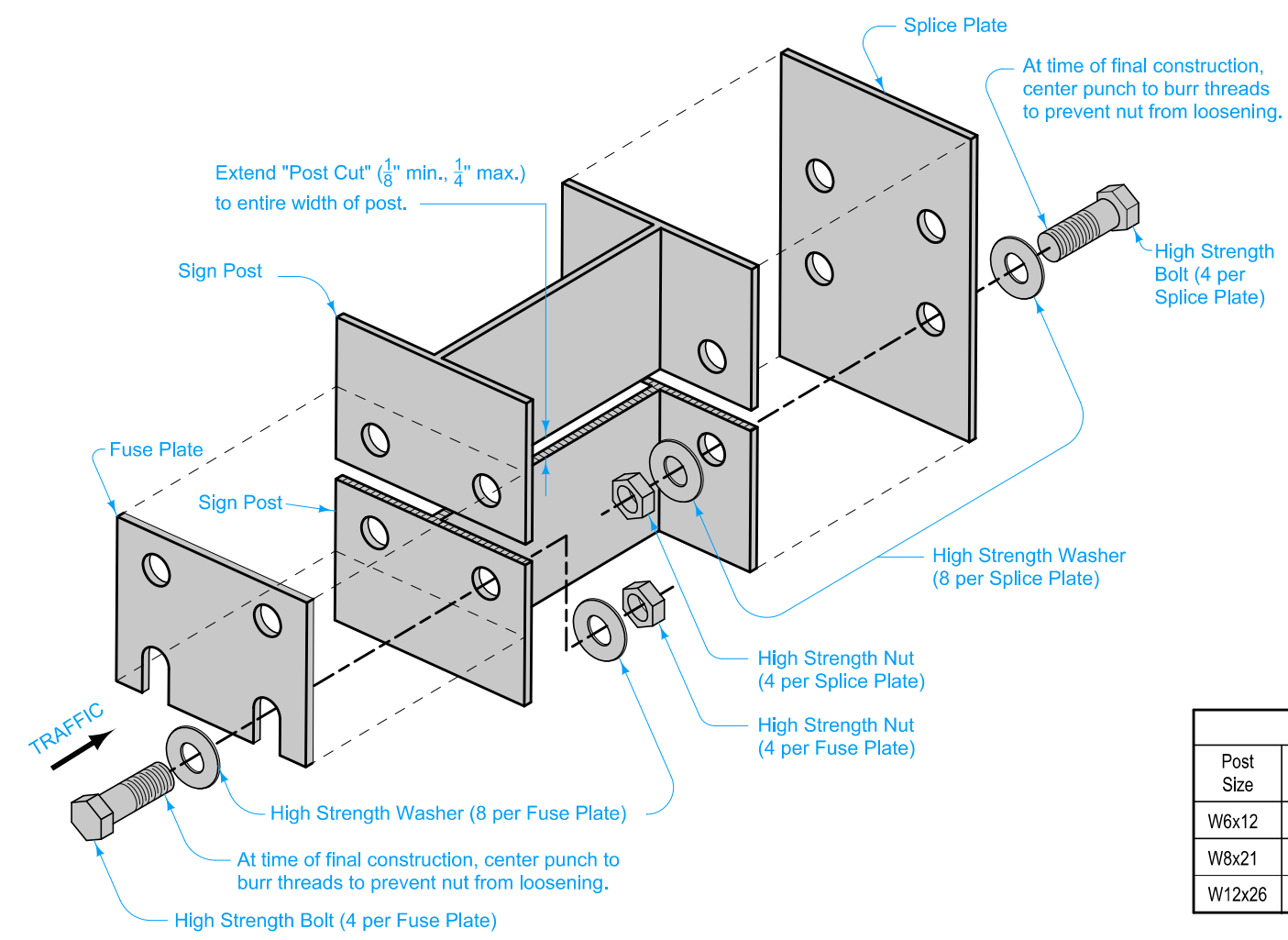

FUSE PLATE ASSEMBLY

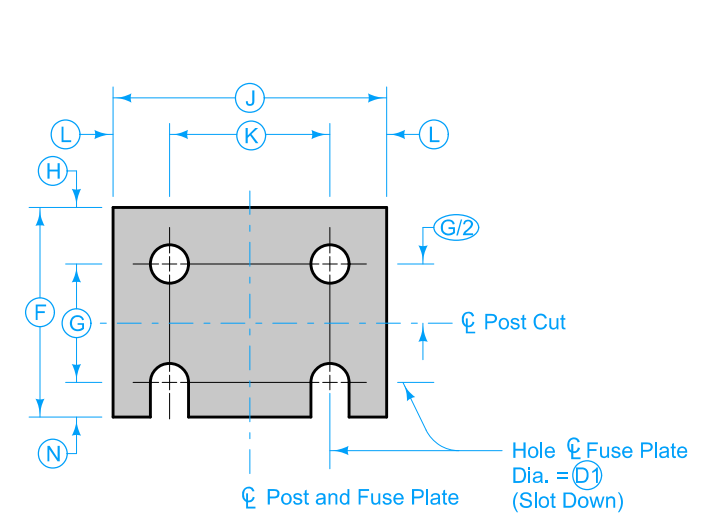

FUSE PLATE
(Thickness T_3)

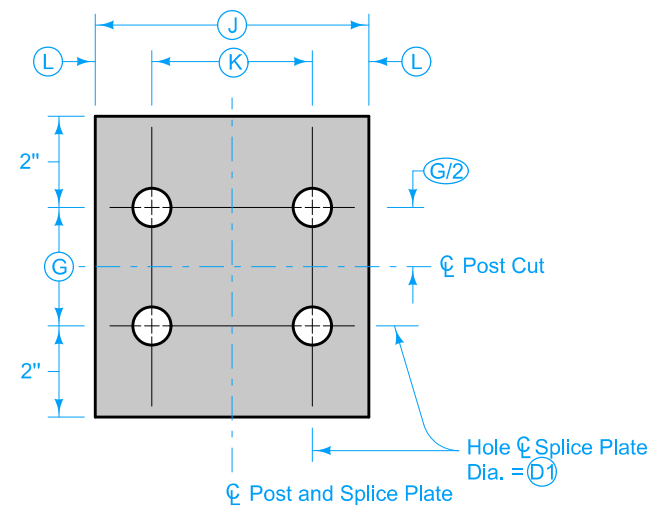

SPLICE PLATE
(Thickness T_4)

Plumb signpost by installing brass stock or strip shims complying with ASTM B36. Furnish two shims each of 0.012" and 0.032" thickness (total of 4 per post).

- ① Not for single post installations.
- ② Refer to Standard Road Plan SI-112 for footing information.

FUSE AND SPLICE PLATE DATA											
Post Size	Bolt Dia.	F	G	H	J	K	L	N	D1	T3	T4
W6x12	5/8"	3 3/4"	2"	1 1/8"	4"	2 1/4"	7/8"	5/8"	1 1/16"	3/8"	1/4"
W8x21	7/8"	4 7/8"	2 1/2"	1 1/2"	5 1/4"	2 3/4"	1 1/4"	7/8"	1 5/16"	5/8"	3/8"
W12x26	7/8"	5 3/8"	3"	1 1/2"	6 1/2"	3 1/2"	1 1/2"	7/8"	1 5/16"	5/8"	3/8"

Possible Contract Item:
Steel Breakaway Sign Post for Type A or B Signs

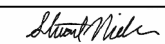
IOWA DOT	REVISION	
	7	10-15-19
STANDARD ROAD PLAN		
SI-113		
SHEET 1 of 2		
REVISIONS: Modified C dimension for W 6 x 12 post in BREAKAWAY BASE DATA table on Sheet 2.		
 APPROVED BY DESIGN METHODS ENGINEER		

**SUPPORT STRUCTURES -
STEEL BREAKAWAY POSTS**

The following Base Plate alternates are considered equivalent:

Alternate 1 - Weld base plates (2 each), to sides of signpost and stub post flanges.

Alternate 2 - Weld base plate (1 each) to end of sign post and stub post. Properly match and align the bolt holes and notches in the stub post plate and the sign post plate as indicated herein.

Grind smooth all welds and galvanizing between Base Plates.

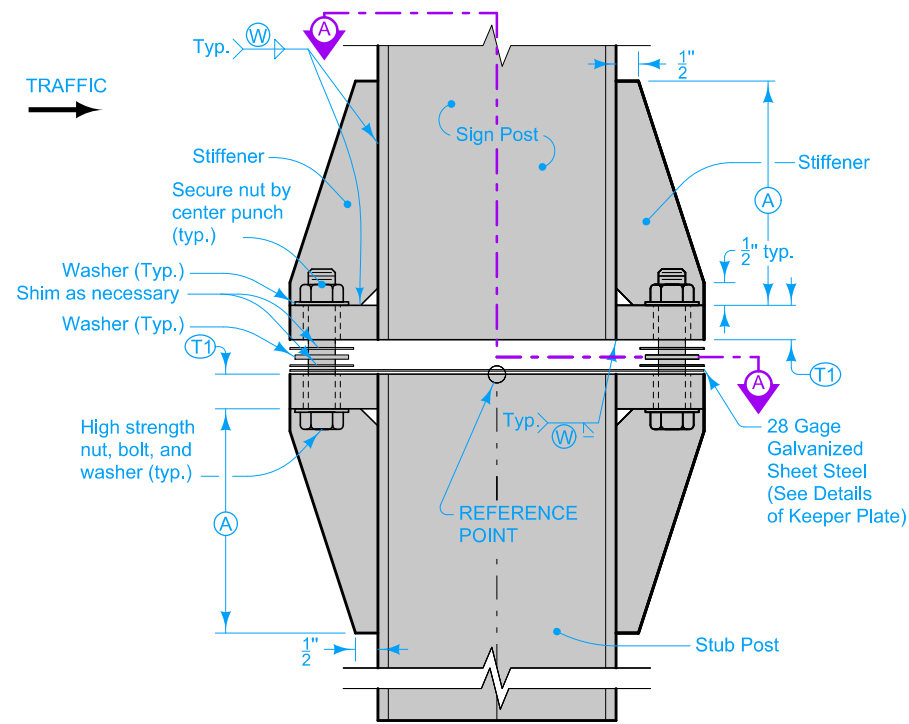

BREAKAWAY BASE
Side View
(Alternate 1)

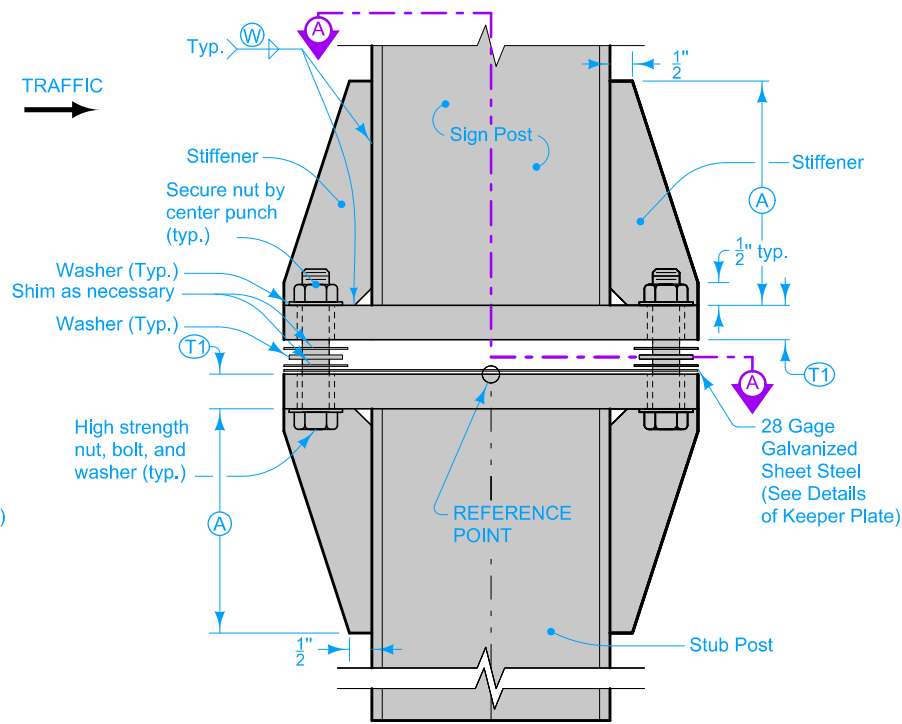

BREAKAWAY BASE
Side View
(Alternate 2)

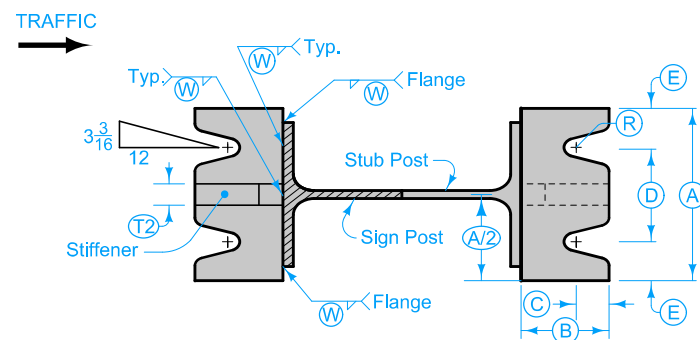

SECTION A-A
PLAN - BASE
(ALTERNATE 1)

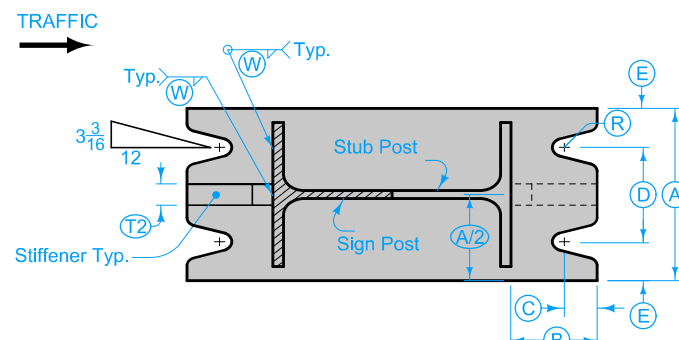

SECTION A-A
PLAN - BASE
(ALTERNATE 2)

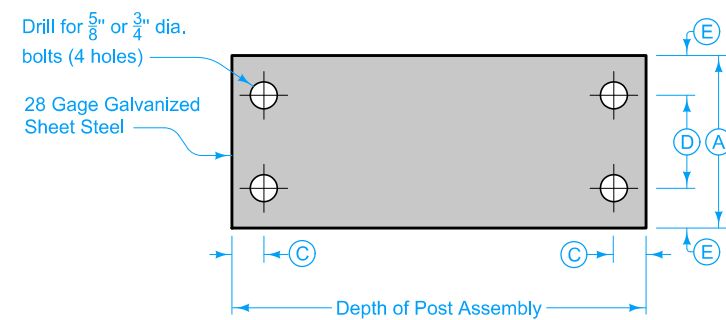

KEEPER PLATE

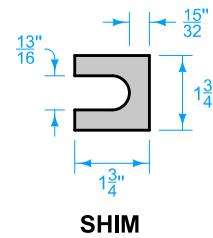

BREAKAWAY BASE DATA										
Post Size	Bolt Size & Torque	A	B	C	D	E	T1	T2	W	R
W 6 x 12	5/8" dia. x 2 3/4" Torque = 37.50 ft. lbs.	5"	2"	3/4"	2 3/4"	1 1/8"	3/4"	1"	1 1/4"	11/32"
W 8 x 21 W 12 x 26	3/4" dia. x 3 1/2" Torque = 62.50 ft. lbs.	6"	2 1/4"	7/8"	3 1/2"	1 1/4"	1"	3/4"	5/16"	13/32"

 STANDARD ROAD PLAN	REVISION	
	7	10-15-19
	SI-113 SHEET 2 of 2	
REVISIONS: Modified C dimension for W 6 x 12 post in BREAKAWAY BASE DATA table on Sheet 2.		
 APPROVED BY DESIGN METHODS ENGINEER		

**SUPPORT STRUCTURES -
STEEL BREAKAWAY POSTS**