

TYPE 1
SHOULDER INSTALLATION

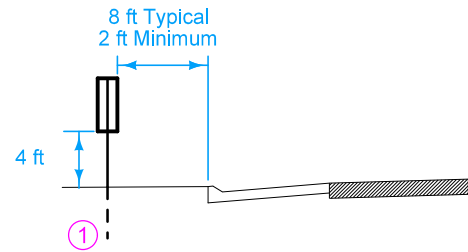

TYPE 2
CURB INSTALLATION

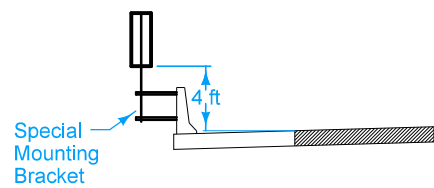

TYPE 3
BRIDGE BARRIER RAIL INSTALLATION

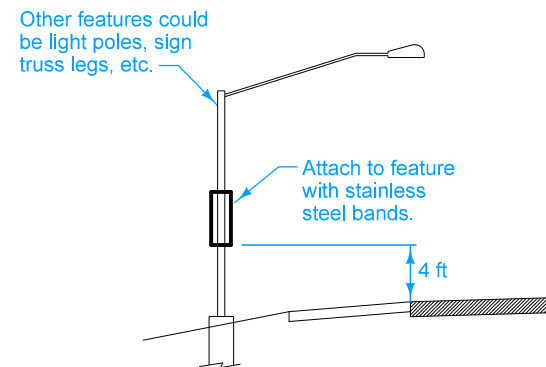

TYPE 4
ATTACHMENT TO OTHER FEATURE

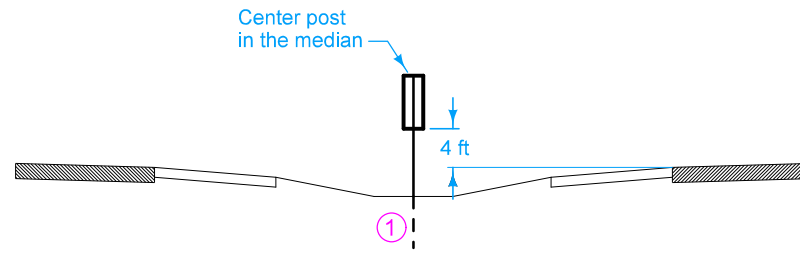

TYPE 5
DEPRESSED MEDIAN INSTALLATION

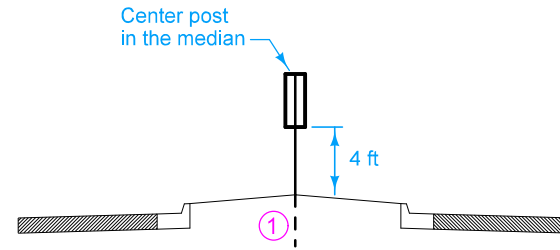

TYPE 6
RAISED MEDIAN INSTALLATION

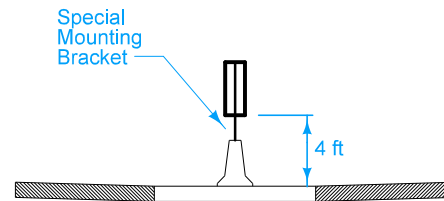

TYPE 7
FULL MEDIAN BARRIER RAIL INSTALLATION

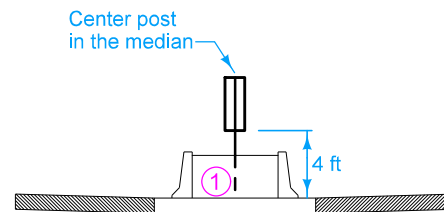

TYPE 8
SPLIT MEDIAN BARRIER RAIL INSTALLATION

Furnish Type 1 delineator posts for each location unless specified otherwise in the plans.

$\frac{3}{8}$ " or $\frac{7}{16}$ " holes in delineators are acceptable.

All dimensions are in inches unless otherwise designated.

① Install post of sufficient length to provide a minimum of 30 inches of embedment when installed at the specified mounting height.

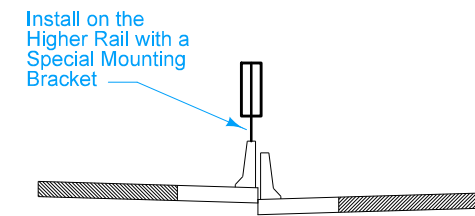

TYPE 9
SPLIT MEDIAN BARRIER RAIL INSTALLATION
WITH GRADE DIFFERENTIAL

Hot dipped galvanized steel bolts, self-locking nuts, and washers.
 $\frac{5}{16}$ " x 2 $\frac{1}{4}$ " - 18 NC hex bolts and hex selflocking nuts with washers
 $\frac{11}{32}$ " I.D. x $\frac{11}{16}$ " O.D. x 0.091".

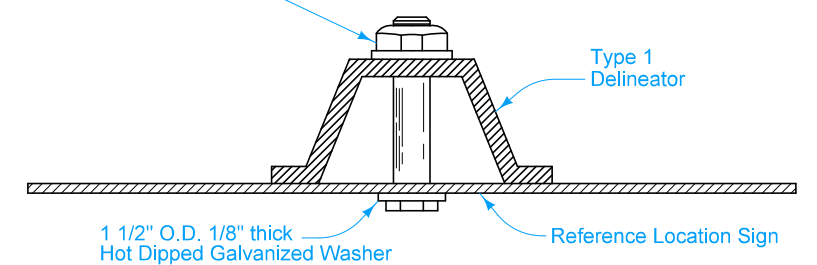

REFERENCE LOCATION SIGN ASSEMBLY
TOP VIEW

	REVISION	
	3	04-18-17
STANDARD ROAD PLAN		SI-171
REVISIONS: Changed title and "milepost" to new Reference Location Sign naming.		SHEET 1 of 4
APPROVED BY DESIGN METHODS ENGINEER		
REFERENCE LOCATION SIGN POSTS		



D10-1A;
1.50" Radius, 0.50" Border, White on Green;
[MILE] C 2K;
[4] C 2K;



D10-2A;
1.50" Radius, 0.50" Border, White on Green;
[MILE] C 2K;
[4] C 2K; [4] C 2K;



D10-3A;
1.50" Radius, 0.50" Border, White on Green;
[MILE] C 2K;
[4] C 2K; [4] C 2K;
[4] C 2K;

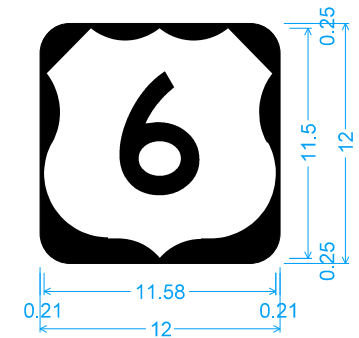

D10-5A;
1.50" Radius, No border, White on Black;

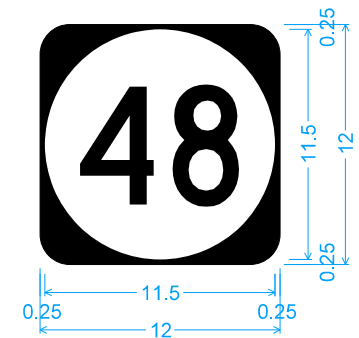

1.50" Radius, No border, White on Black;
Rounded Rectangle 5.75" Radius;

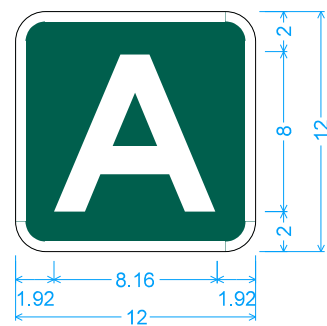

D10-7A;
1.50" Radius, 0.50" Border, White on Green;
[A] E 2K;

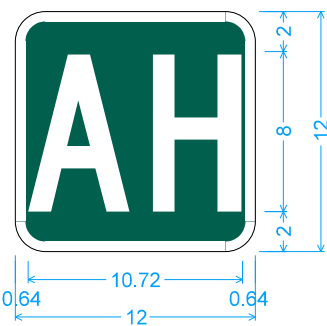

D10-8A;
1.50" Radius, 0.50" Border, White on Green;
[AH] C 2K;

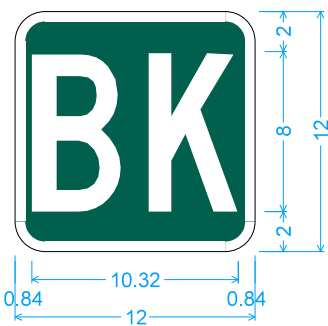

D10-9A;
1.50" Radius, 0.50" Border, White on Green;
[BK] C 2K;

	REVISION	
	3	04-18-17
	SI-171 SHEET 2 of 4	
REVISIONS: Changed title and "milepost" to new Reference Location Sign naming.		
 APPROVED BY DESIGN METHODS ENGINEER		
REFERENCE LOCATION SIGN POSTS		

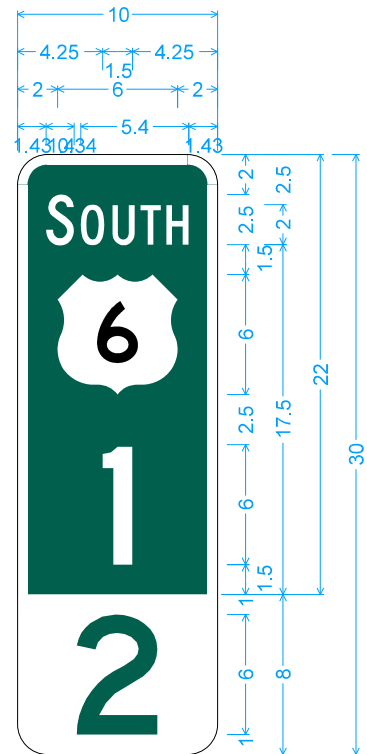

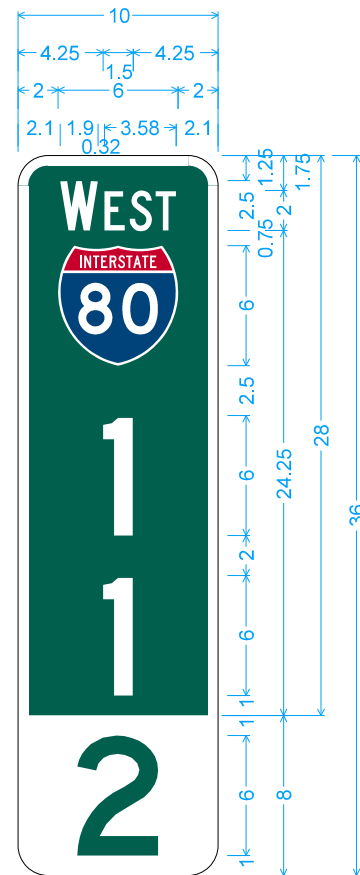

2.96 ← 4.08 → 2.96 |
 D10-1D;
 1.50" Radius, 0.50" Border, White on Green;
 [SOUTH] C 2K;
 [1] D 2K;
 1.50" Radius, No border, Green on White;
 [2] D 2K;

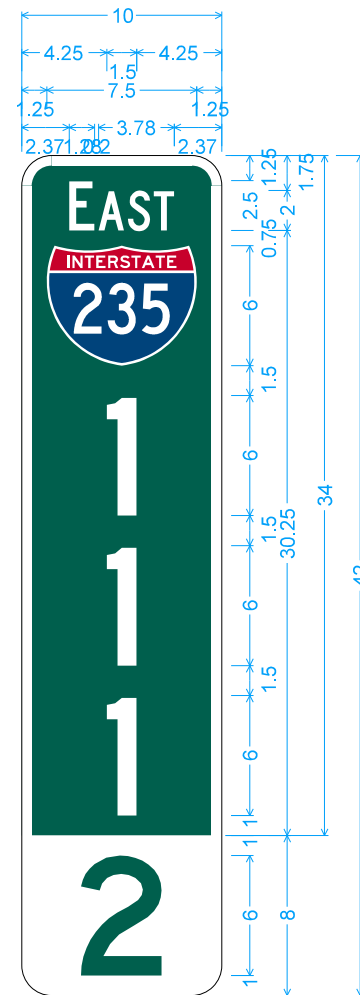

2.96 ← 4.08 → 2.96 |
 D10-2D;
 1.50" Radius, 0.50" Border, White on Green;
 [WEST] C 2K;
 [1] D 2K;
 [1] D 2K;
 1.50" Radius, No border, Green on White;
 [2] D 2K;



2.96 ← 4.08 → 2.96 |
 D10-3D;
 1.50" Radius, 0.50" Border, White on Green;
 [EAST] C 2K;
 [1] D 2K;
 [1] D 2K;
 [1] D 2K;
 1.50" Radius, No border, Green on White;
 [2] D 2K;

 STANDARD ROAD PLAN	REVISION	
	3	04-18-17
	SI-171	
SHEET 3 of 4		
REVISIONS: Changed title and "milepost" to new Reference Location Sign naming.		
 APPROVED BY DESIGN METHODS ENGINEER		
REFERENCE LOCATION SIGN POSTS		

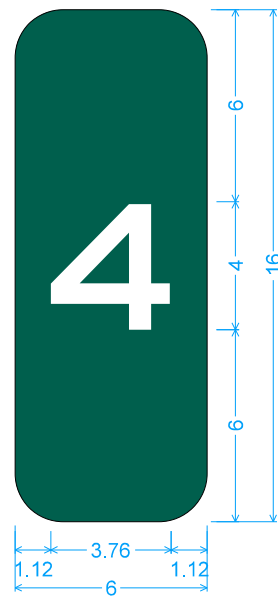

D10-1;
1.50" Radius, No border, White on Green;
[4] E 2K;

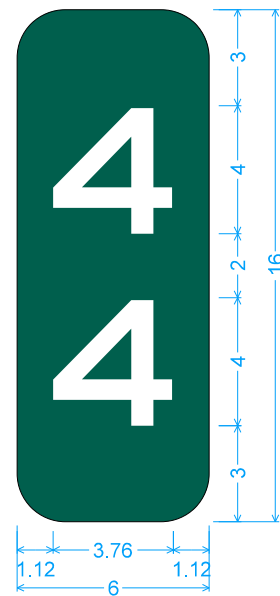

D10-2;
1.50" Radius, No border, White on Green;
[4] E 2K;
[4] E 2K;

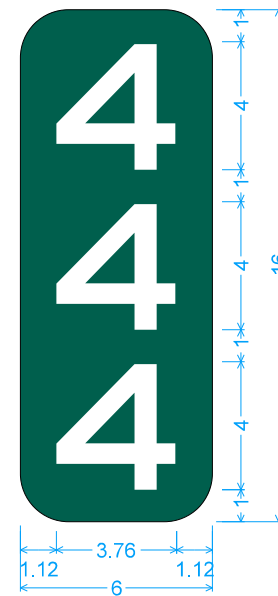

D10-3;
1.50" Radius, No border, White on Green;
[4] E 2K;
[4] E 2K;
[4] E 2K;

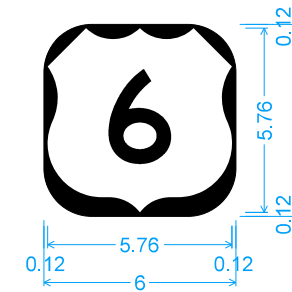

D10-5;
1.50" Radius, No border, White on Black;

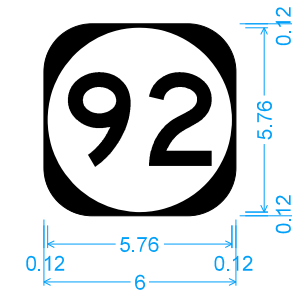

D10-6;
1.50" Radius, No border, White on Black;
State Highway 92 M1-5;

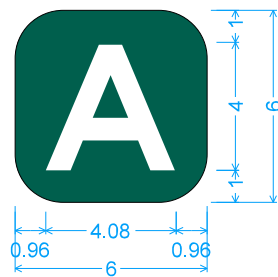

D10-7;
1.50" Radius, No border, White on Green;
[A] E 2K;

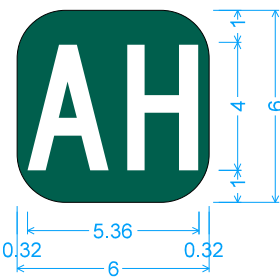

D10-8;
1.50" Radius, No border, White on Green;
[AH] C 2K;

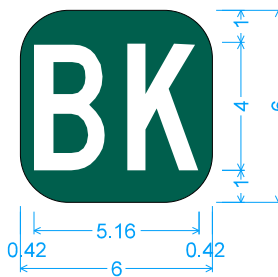

D10-9;
1.50" Radius, No border, White on Green;
[BK] C 2K;

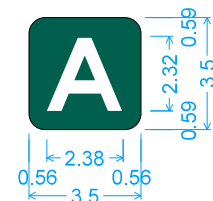

0.50" Radius, No border, White on Green;
[A] E 2K;

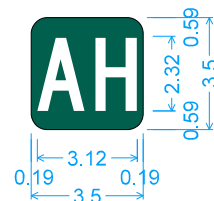

0.50" Radius, No border, White on Green;
[AH] C 2K;

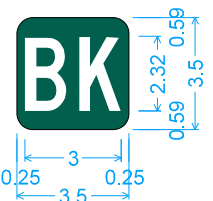

0.50" Radius, No border, White on Green;
[BK] C 2K;

	REVISION	
	3	04-18-17
STANDARD ROAD PLAN		SI-171
		SHEET 4 of 4
REVISIONS: Changed title and "milepost" to new Reference Location Sign naming.		
APPROVED BY DESIGN METHODS ENGINEER		
REFERENCE LOCATION SIGN POSTS		