

RIGID DELINEATOR MOUNTINGS

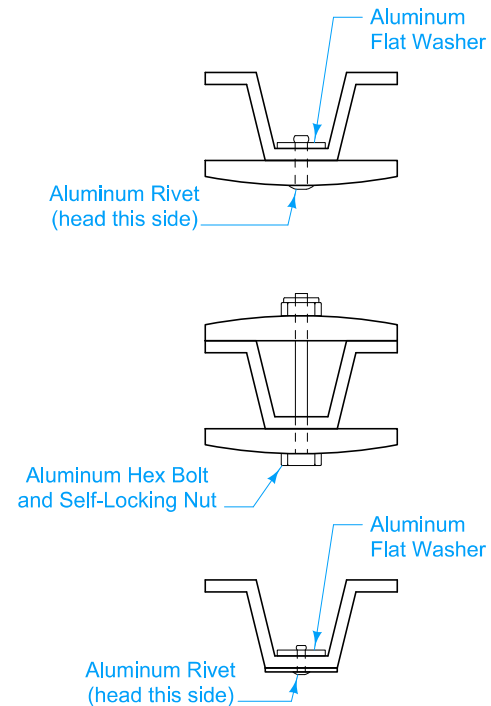

ATTACHMENTS

Place delineators at a constant distance from the edge of traveled way and/or the edge of shoulder.

The delineator height is measured from the edge of traveled way or the face of curb.

When placed behind curb, the delineator offset is measured from the face of curb. Allowable offsets are 2 feet minimum and 8 feet maximum. If the curb is part of a shoulder, maintain at least a minimum 8 foot offset from the edge of traveled way.

When placed on the foreslope, the delineator offset is measured from the edge of shoulder. Allowable offsets are 2 feet minimum and 8 feet maximum. However, for shoulders less than 6 feet in width, maintain a minimum 8 feet to the edge of traveled way.

Refer to the project plans for specific offset dimensions.

Furnish white, yellow, and/or red reflectors as specified in the project plans.

Furnish Type I delineator posts. Post lengths are to be sufficient to ensure the proper installation height and provide a minimum of 2'-6" embedment. See Table I for post lengths for various slope and offset conditions.

3/8" or 7/16" holes in the delineators are acceptable.

Install delineators truly vertical.

Delineators placed along freeways and expressways are to be spaced every 0.05 mile along the thru roadway. Placements are based on the reference post marker. A Delineator Reference Point Plaque is required on each delineator for both directions of travel.

Fabricate plaques from 0.063 inch thick sheet aluminum of the appropriate dimensions. Use non-reflectORIZED sheeting. White for the background, and black for the numerals.

Attach single reflectors to the post with an aluminum, brazier head, blind rivet of 3/16-inch diameter and a grip range of 0.376 to 0.625 inches, and an aluminum flat washer of 0.193 in. ID x 0.750 in. OD x 0.091 in. thickness.

Attach back to back reflectors to the post with an aluminum 3/16 in. dia x 2 1/2 in. length hex head bolt with a matching self-locking nut.

Attach plaques to the post with an aluminum, brazier head, blind rivet of 1/8 inch diameter and a grip range of 0.126 to 0.250 inches, and an aluminum flat washer of 0.129" ID x 0.750" OD x 0.091" thickness.

Furnish materials complying with Section 4186 of the Standard Specifications.

- Possible Contract Items:
 Delineator, Rigid - Type I
 Delineator, Rigid - Type IA
 Delineator, Rigid - Type II
 Delineator, Rigid - Type III

Possible Tabulation:
 190-25

Post Lengths for Shoulder Installation					
Offset ft	Foreslope Rate (FS:1)				
	10:1	6:1	4:1	3:1	2:1
2	8	8	8	8	8
4	8	8	8	10	10
6	8	8	10	10	10
8	8	10	10	10	12

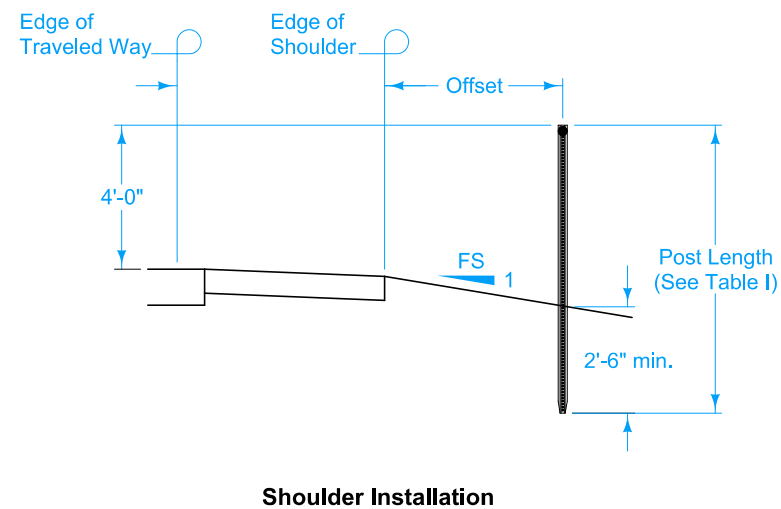

Shoulder Installation

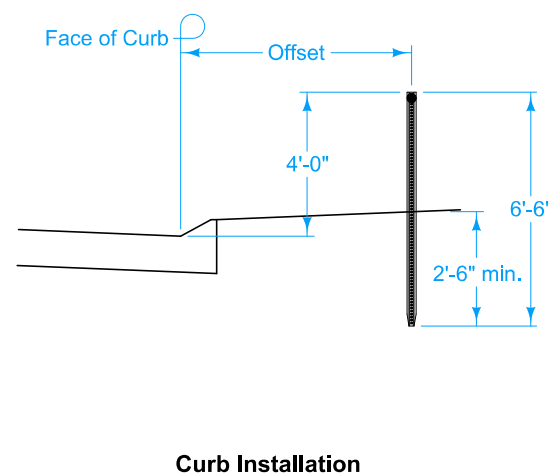

Curb Installation

DELINEATOR POST LOCATIONS

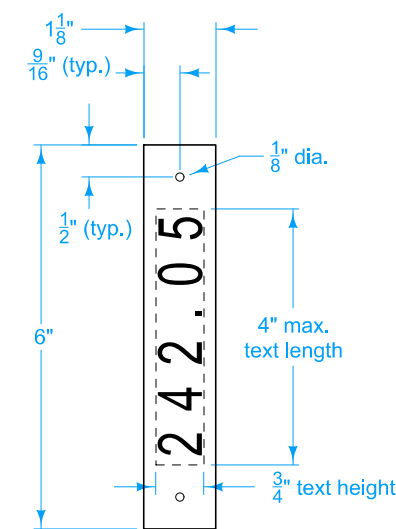

DELINEATOR REFERENCE POINT PLAQUE

	REVISION
	3 04-19-16
STANDARD ROAD PLAN	
SI-172	
SHEET 1 of 1	
REVISIONS: Widened general notes column to add possible contract items and possible tabulation.	
APPROVED BY DESIGN METHODS ENGINEER	
DELINEATORS	