

TYPE 1
SHOULDER INSTALLATION

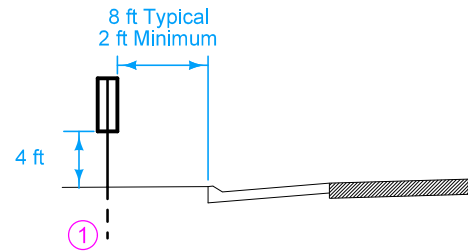

TYPE 2
CURB INSTALLATION

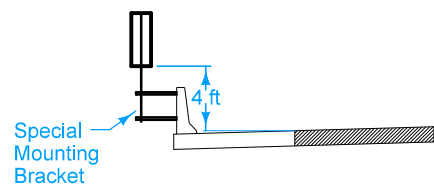

TYPE 3
BRIDGE BARRIER RAIL INSTALLATION

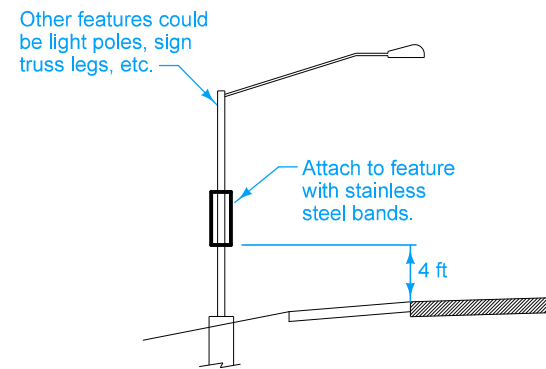

TYPE 4
ATTACHMENT TO OTHER FEATURE

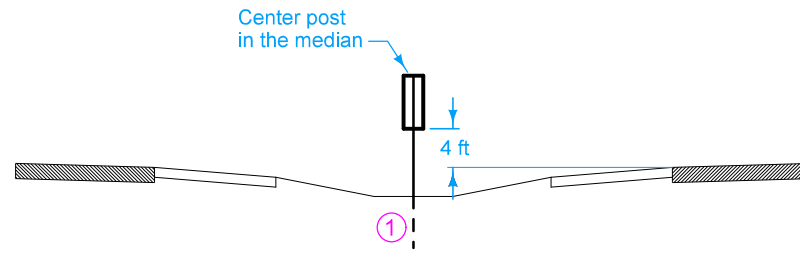

TYPE 5
DEPRESSED MEDIAN INSTALLATION

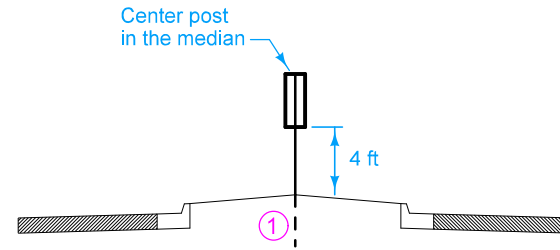

TYPE 6
RAISED MEDIAN INSTALLATION

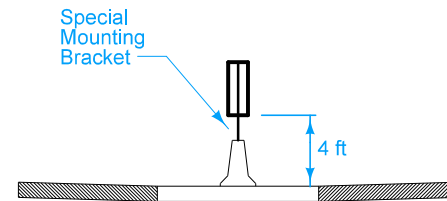

TYPE 7
FULL MEDIAN BARRIER RAIL INSTALLATION

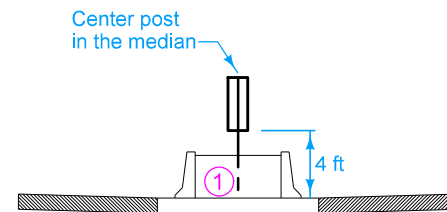

TYPE 8
SPLIT MEDIAN BARRIER RAIL INSTALLATION

Furnish Type 1 delineator posts for each location unless specified otherwise in the plans.
 $\frac{3}{8}$ " or $\frac{7}{16}$ " holes in delineators are acceptable.
 All dimensions are in inches unless otherwise designated.

① Install post of sufficient length to provide a minimum of 30 inches of embedment when installed at the specified mounting height.

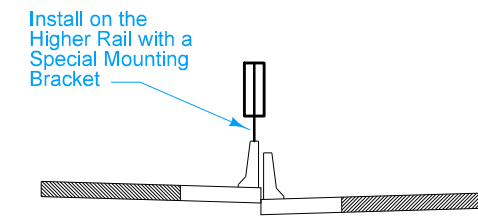

TYPE 9
SPLIT MEDIAN BARRIER RAIL INSTALLATION
WITH GRADE DIFFERENTIAL

Hot dipped galvanized steel bolts, self-locking nuts, and washers.
 $\frac{5}{16}$ " x 2 $\frac{1}{4}$ " - 18 NC hex bolts and hex selflocking nuts with washers
 $\frac{11}{32}$ " I.D. x $\frac{11}{16}$ " O.D. x 0.091"

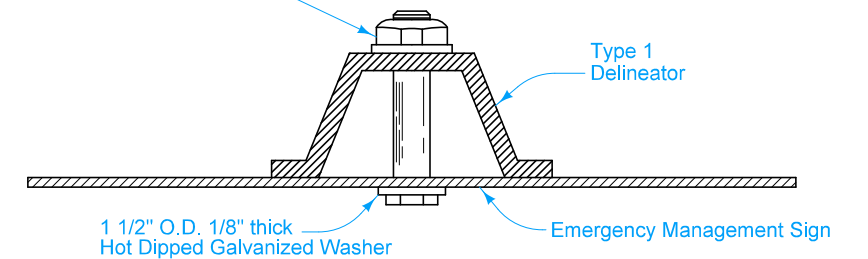

EMERGENCY MANAGEMENT SIGN ASSEMBLY
TOP VIEW

	REVISION	
	New	04-21-20
STANDARD ROAD PLAN		SI-174
REVISIONS: New.		SHEET 1 of 2

APPROVED BY DESIGN METHODS ENGINEER

**EMERGENCY MANAGEMENT
RAMP SIGNING**

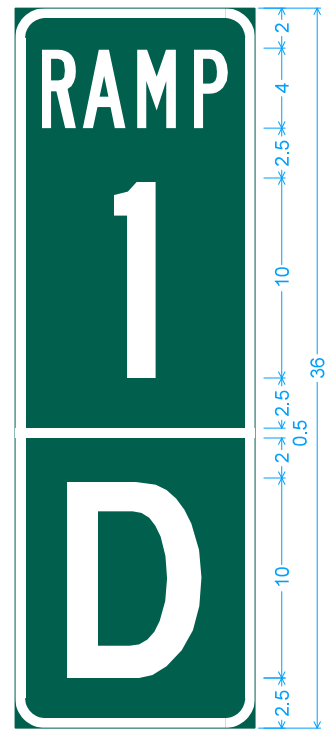

1.5" Radius, 0.5" Border, White on Green;
 [RAMP] B 2K;
 [1] C 2K; [D] D 2K;



1.5" Radius, 0.5" Border, White on Green;
 [RAMP] B 2K;
 [1] C 2K; [2] C 2K;
 [D] D 2K;

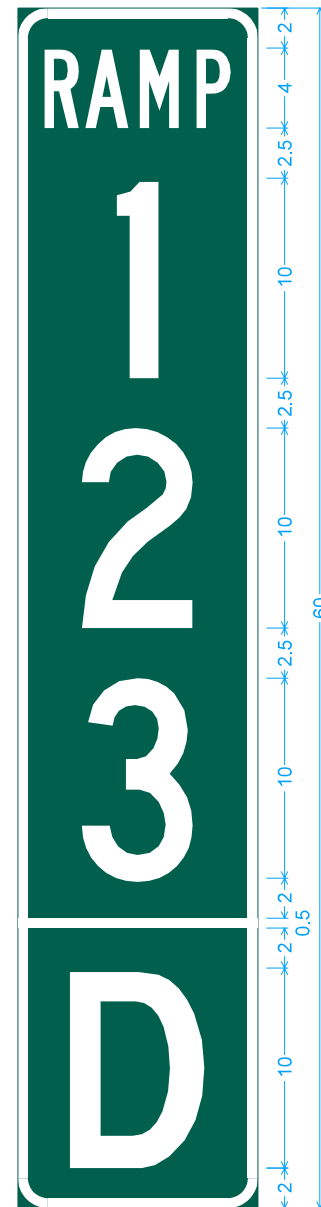

1.5" Radius, 0.5" Border, White on Green;
 [RAMP] B 2K;
 [1] C 2K; [2] C 2K;
 [3] C 2K; [D] D 2K;

	REVISION	
	New	04-21-20
STANDARD ROAD PLAN		SI-174
REVISIONS: New.		SHEET 2 of 2
APPROVED BY DESIGN METHODS ENGINEER		
EMERGENCY MANAGEMENT RAMP SIGNING		