

- ① SW-601 Type A or SW-602 Type G casting.
- ② Place bedding material to springline of pipe.
- ③ Prevent riser from bearing on pipe by providing an arched opening with a diameter up to 6 inches larger than pipe diameter.

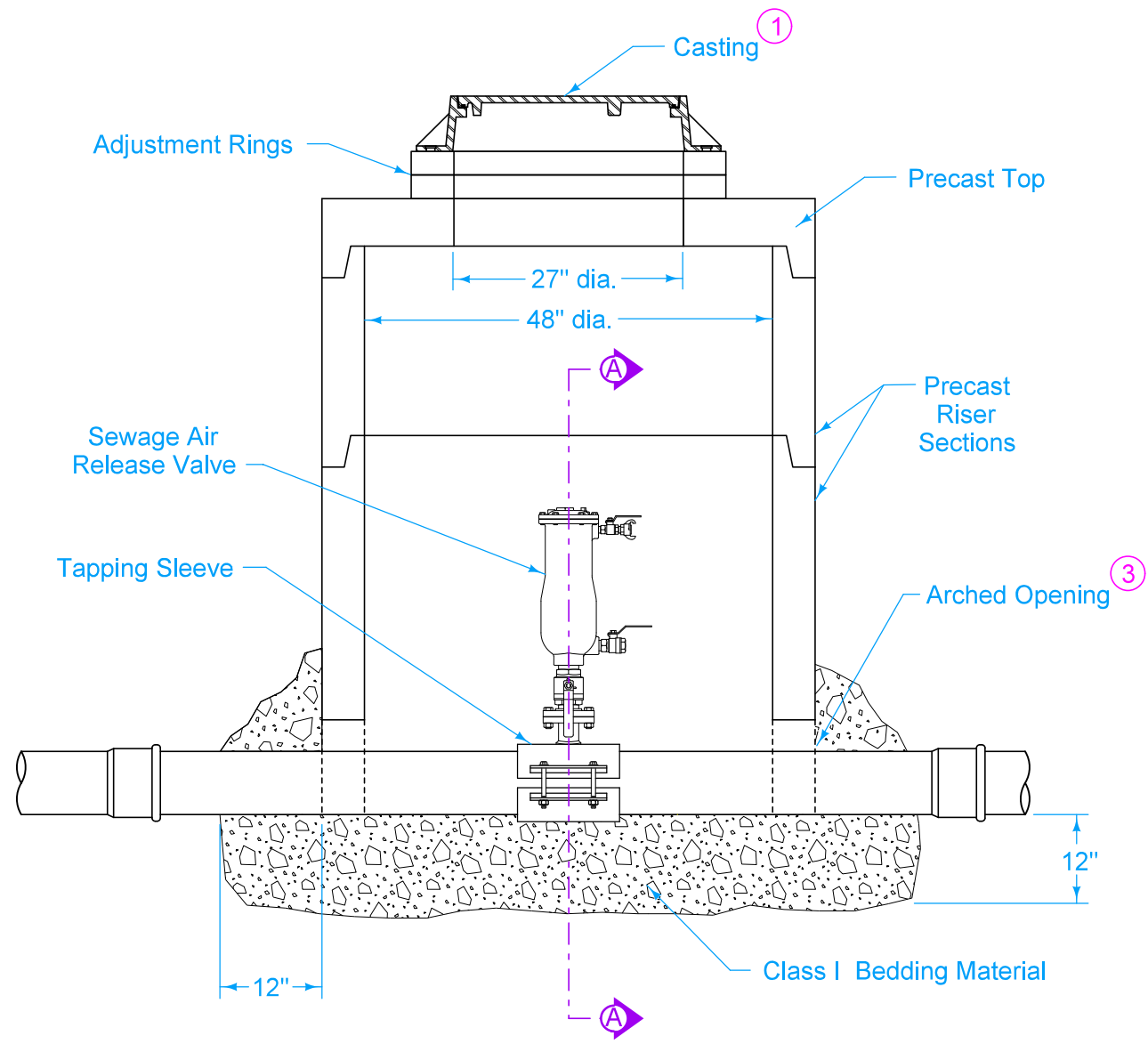

TYPICAL SECTION

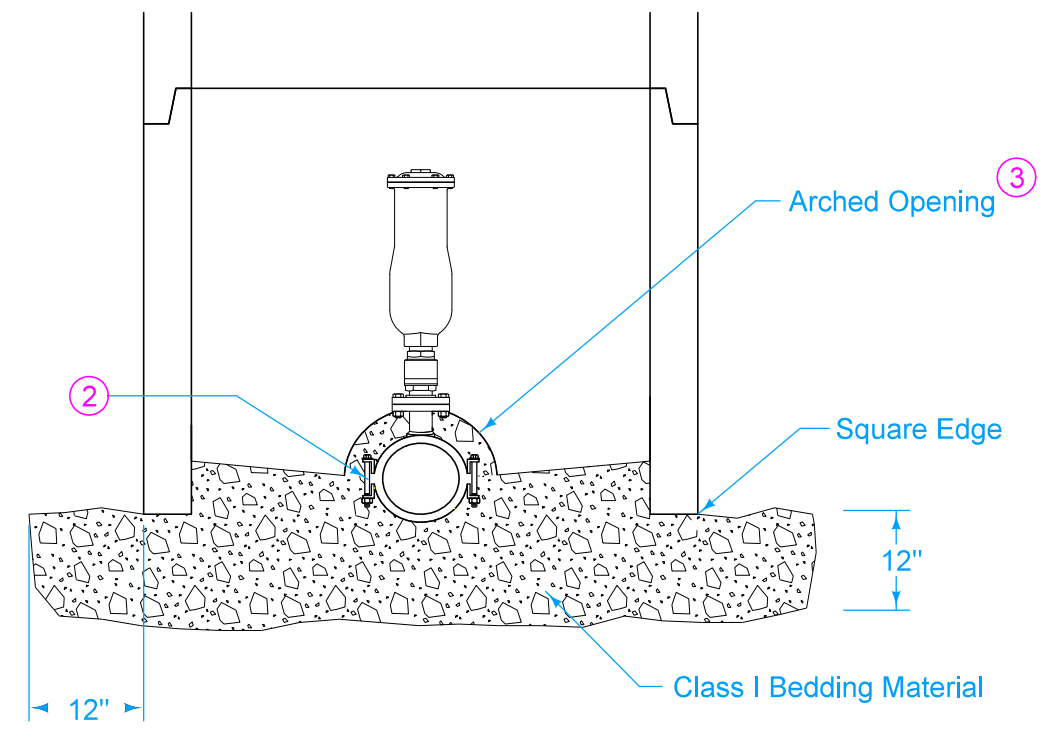

SECTION A-A

FIGURE 4010.202 SHEET 1 OF 1

SUDAS	IOWA DOT	REVISION	
		2	04-21-20
FIGURE 4010.202	STANDARD ROAD PLAN	SW-202	
		SHEET 1 of 1	
REVISIONS: Changed 1 to I on Bedding Material.			
Paul D. Wrigans SUDAS DIRECTOR		Stuart Miller DESIGN METHODS ENGINEER	
SEWAGE AIR RELEASE VALVE PIT			