

Dimensions		
"S" (%)	"H1" (In.)	"H2" (In.)
1	16.33	16.69
2	16.67	17.38
3	17.00	18.07
4	17.33	18.76
5	17.67	19.45
6	18.00	20.14

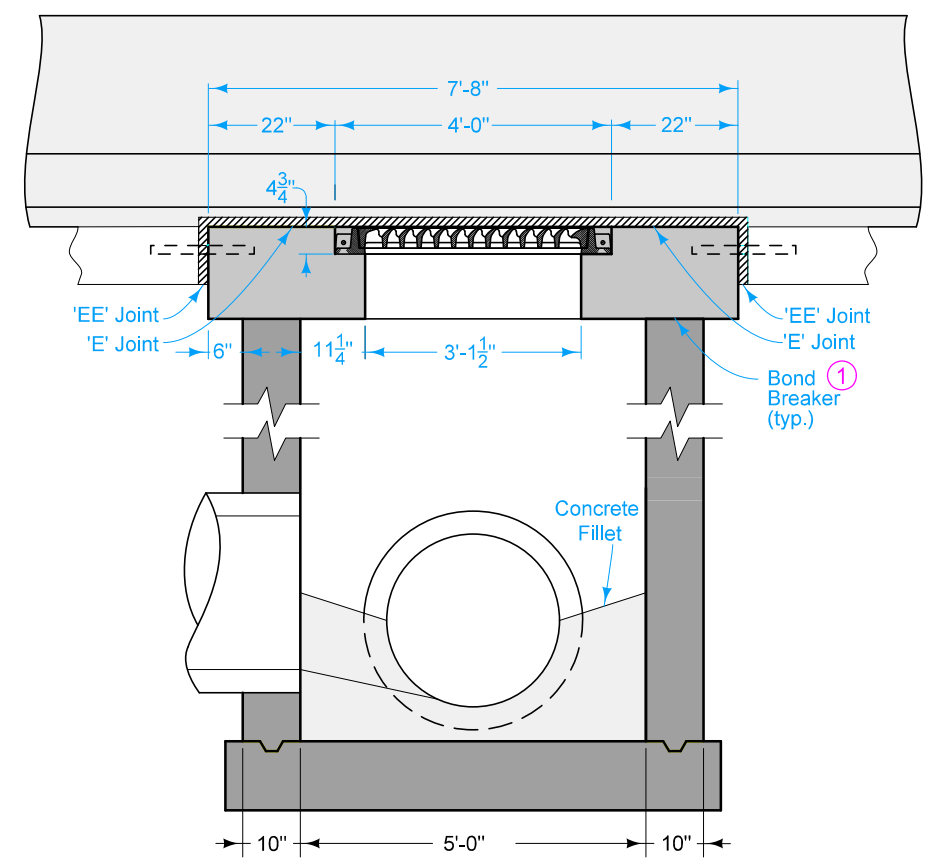
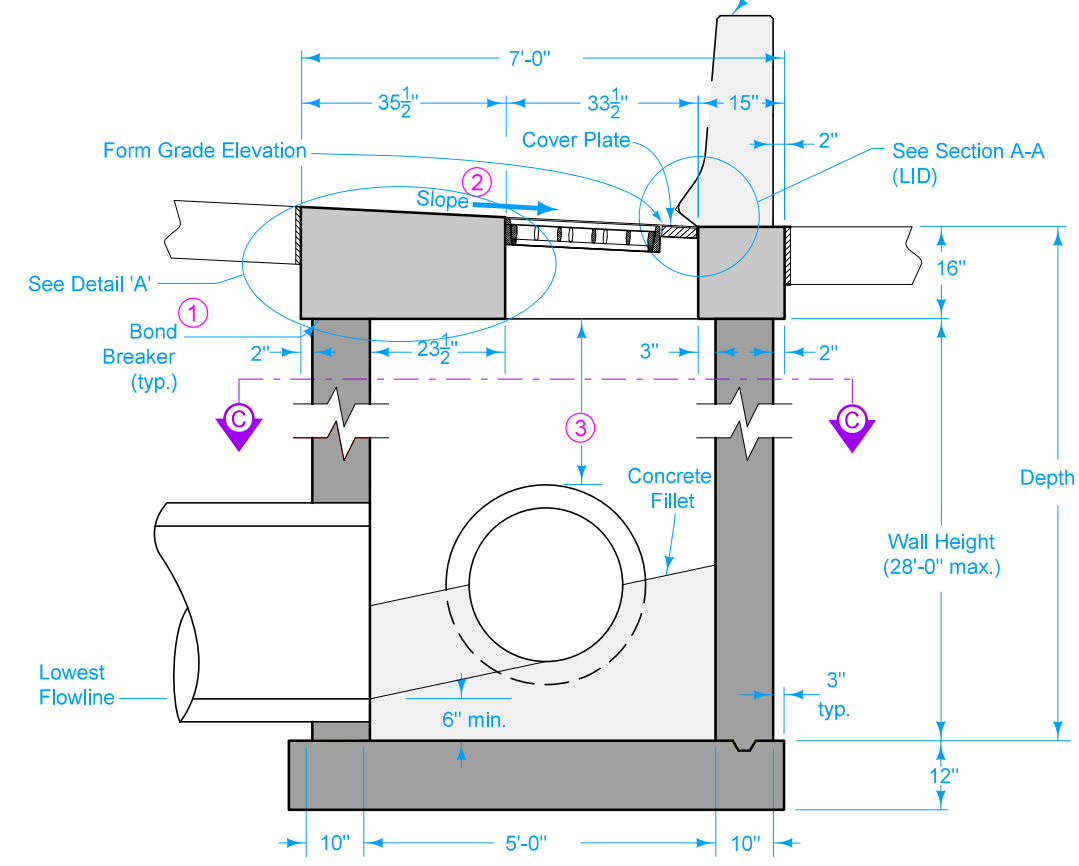

Cover plate and edge armor steel to be ASTM A 36, galvanized after fabrication.

Remove cover plate before constructing concrete barrier.

Cast frames into intake top so tops of grates are 1/4" below Form Grade Elevation. Bolt intake frames together on both sides with four 1/2" x 4" bolts.

For joint details, refer to PV-101.

Maximum pipe diameter is 48 inches.

- 1 Trowel smooth and place two layers of 30 pound roofing felt to prevent bond.
- 2 Match slope of top and grade to slope of adjacent pavement.
- 3 12 inch minimum wall height above all pipes.

Possible Contract Item:
Barrier Intake, SW-549

Possible Tabulation:
104-5B

	REVISION	
	5	04-17-18
STANDARD ROAD PLAN		SW-549
		SHEET 1 of 5
REVISIONS: Changed 'Invert' callout to 'Concrete Fillet'. Added maximum pipe diameter.		
APPROVED BY DESIGN METHODS ENGINEER		
SINGLE-GRATE BARRIER INTAKE, RECTANGULAR		

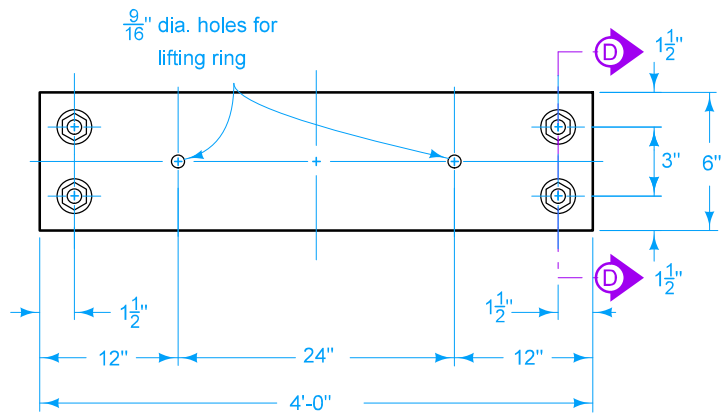

PLAN

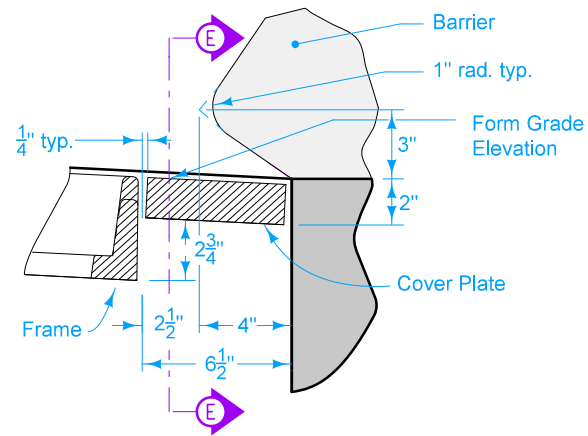

SECTION A-A (LID)

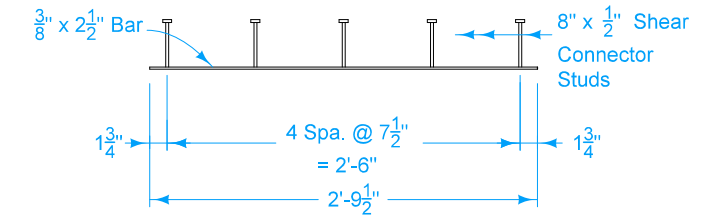

FRAME RING (2 required)

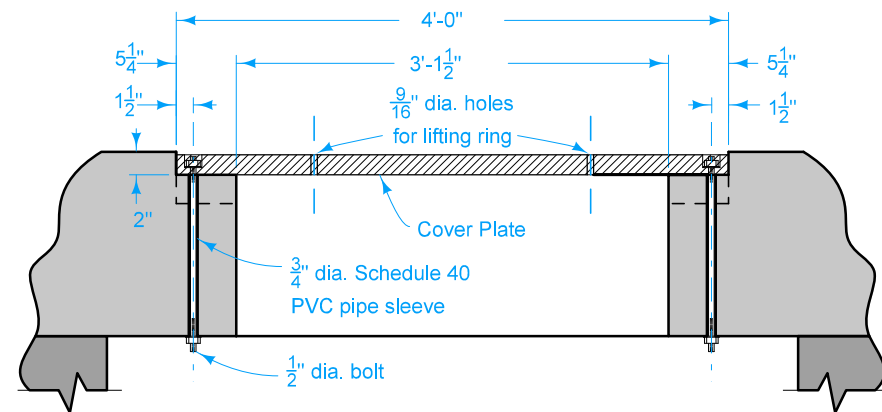

SECTION E-E

COVER PLATE

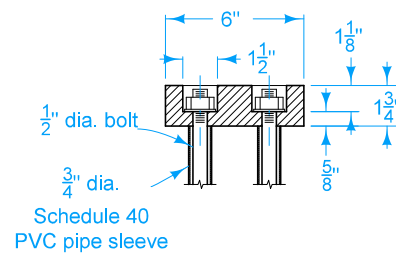

SECTION D-D

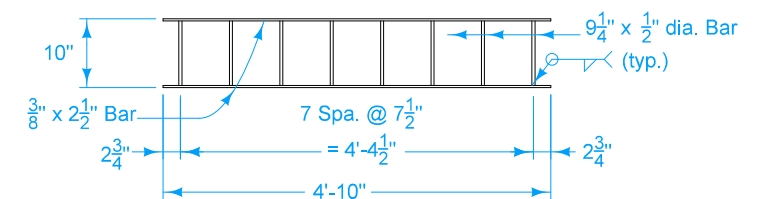

EDGE ARMOR (4 required)

	REVISION	
	5	04-17-18
STANDARD ROAD PLAN		SW-549
		SHEET 2 of 5

REVISIONS: Changed 'Invert' callout to 'Concrete Filet'. Added maximum pipe diameter.

Shawn Miller
APPROVED BY DESIGN METHODS ENGINEER

SINGLE-GRATE BARRIER INTAKE, RECTANGULAR

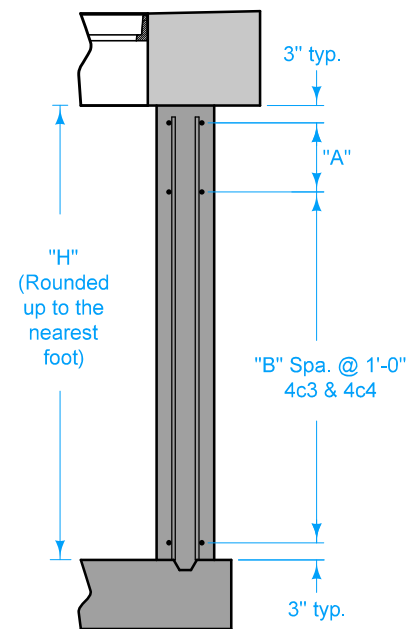

PART SECTION A-A
(Where H = 3' to 14')

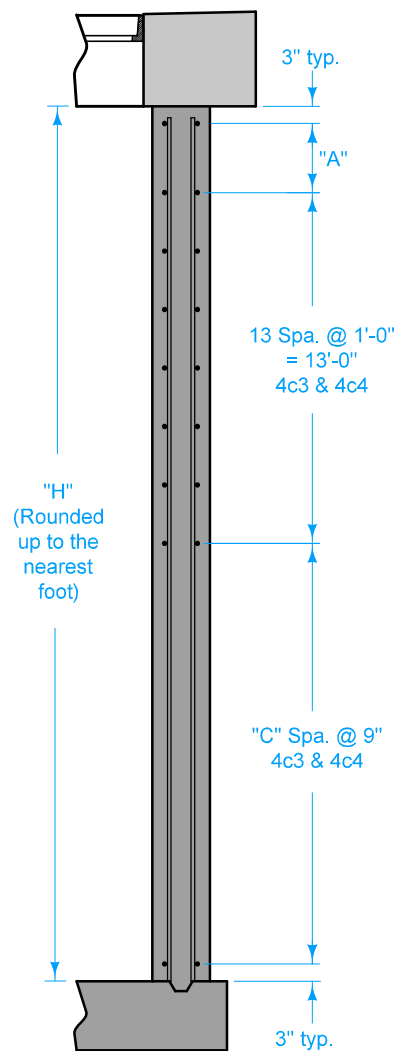

PART SECTION A-A
(Where H = 15' to 28')

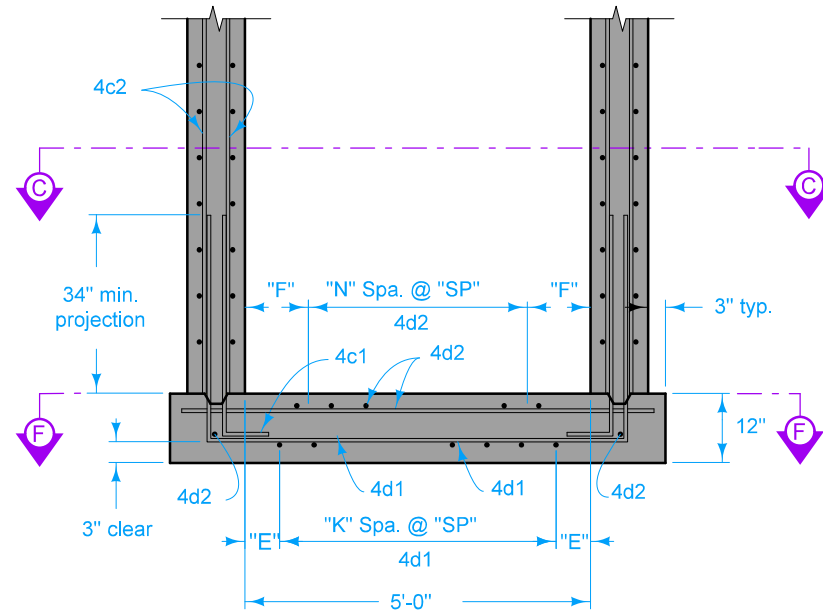

SECTION A-A

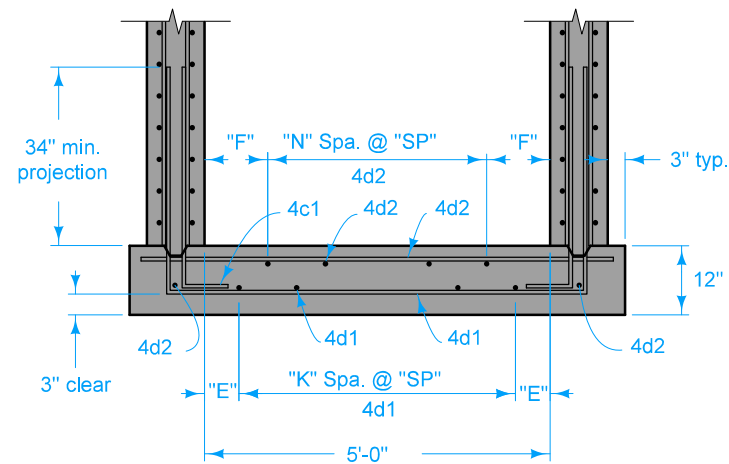

SECTION B-B

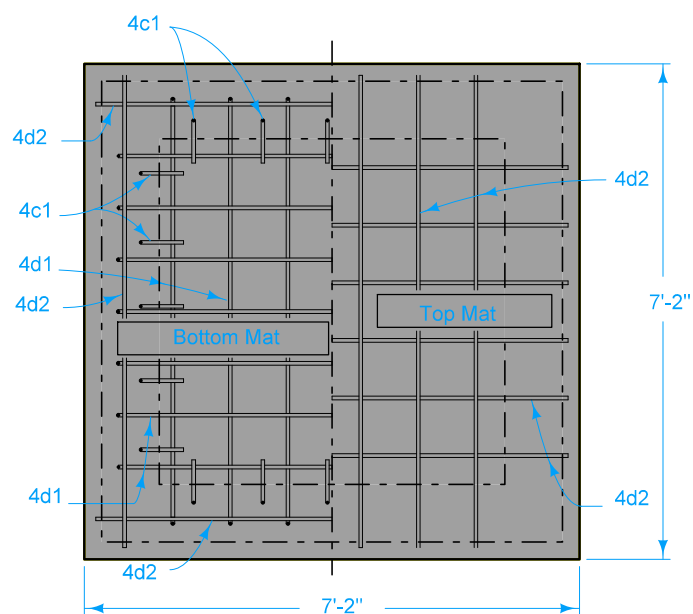

SECTION F-F
BASE REINFORCING

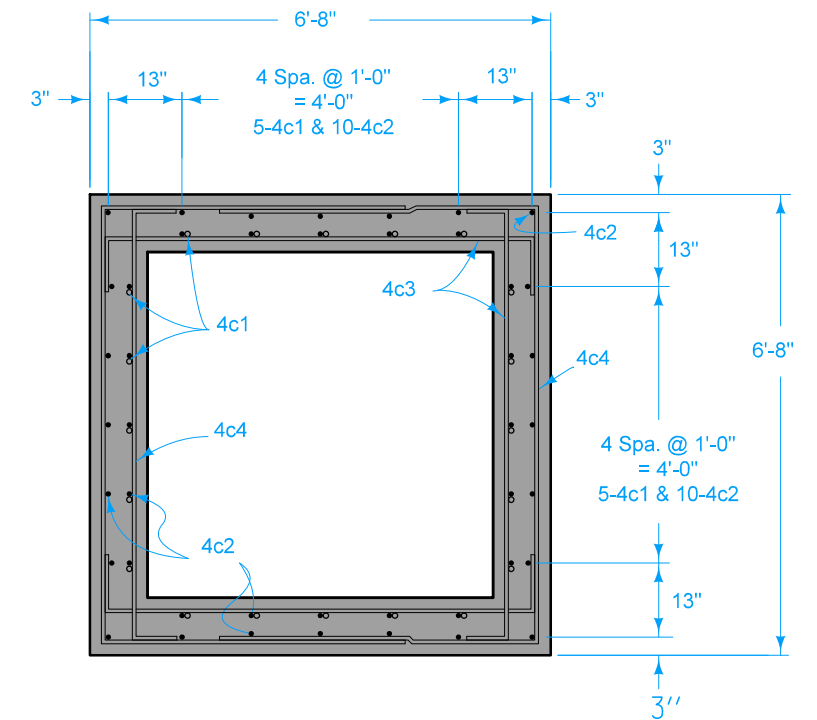
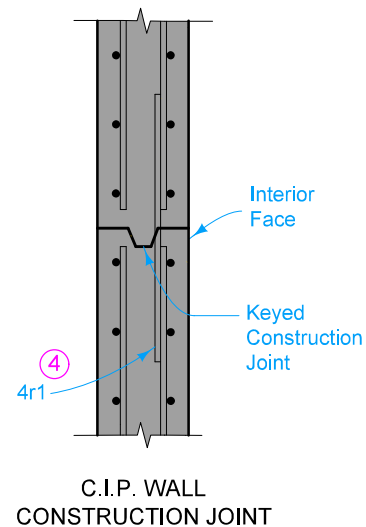
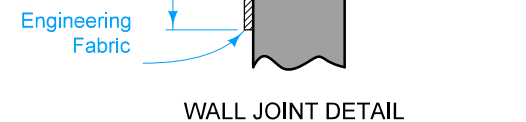
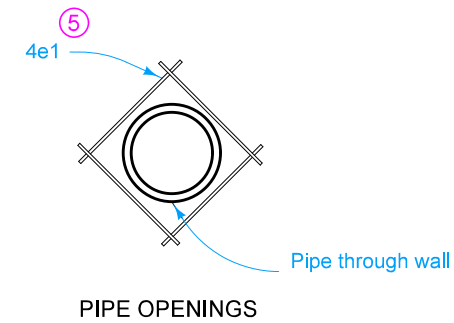

SECTION C-C

- ④ Install 4r1 x 3'-0" dowel bars at 12-inch spacing at all wall joints. Twenty-four 4r1 bars required per joint, total weight = 48 lbs.
- ⑤ 4e1 bar length to be pipe diameter plus 12 inches. Place 4e1 bar inside of vertical reinforcing. Shift main reinforcing bars as required for pipe entrance. Field cut bars to maintain 3 inch clearance from bottom and 2 inch clearance from face of walls. Four 4e1 bars required per pipe entrance.

	REVISION	
	5	04-17-18
STANDARD ROAD PLAN		SW-549
REVISIONS: Changed 'Invert' callout to 'Concrete Filet'. Added maximum pipe diameter.		SHEET 3 of 5
 APPROVED BY DESIGN METHODS ENGINEER		
SINGLE-GRATE BARRIER INTAKE, RECTANGULAR		

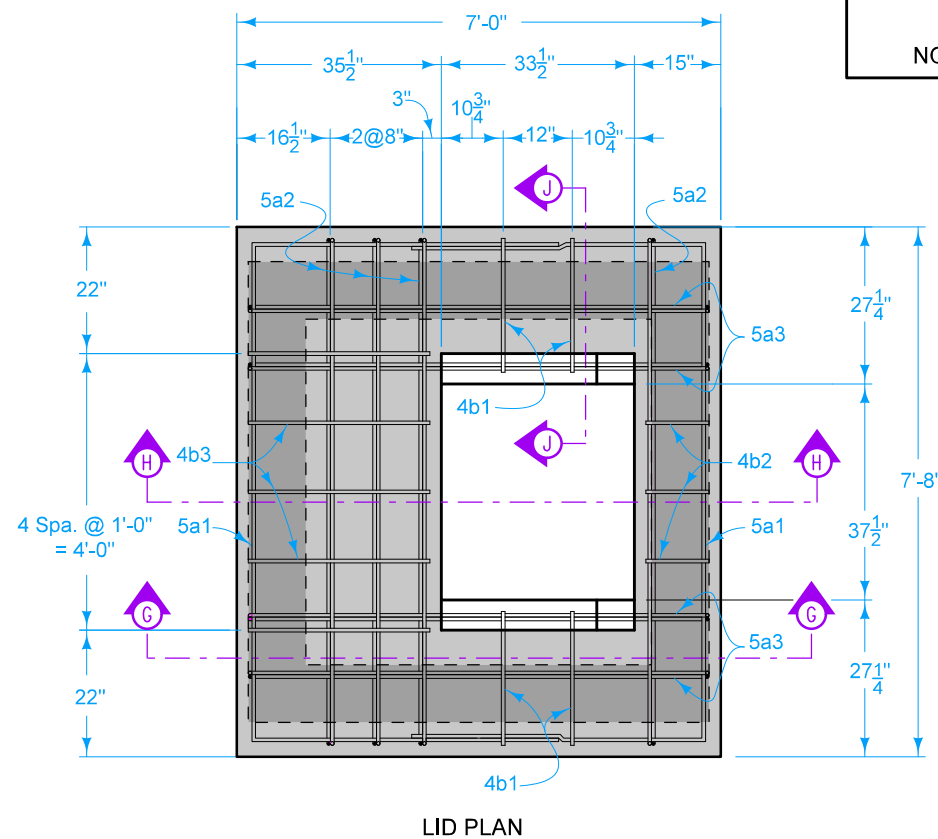
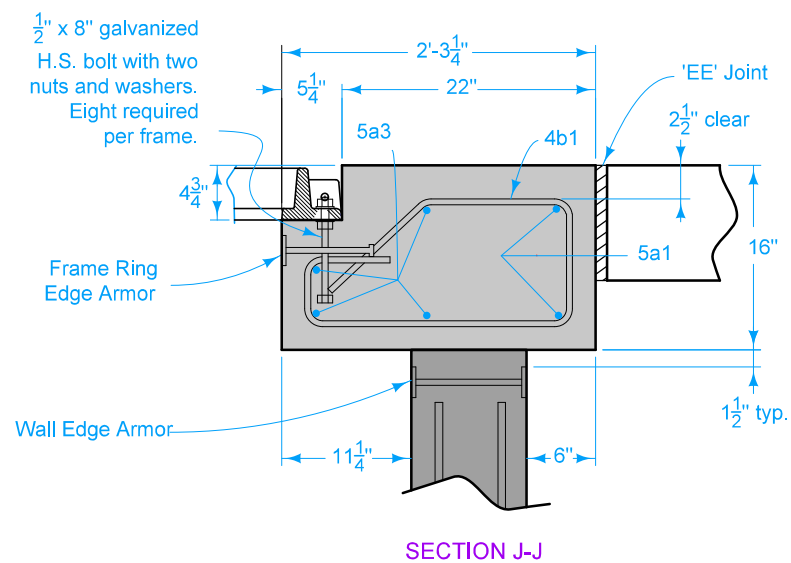
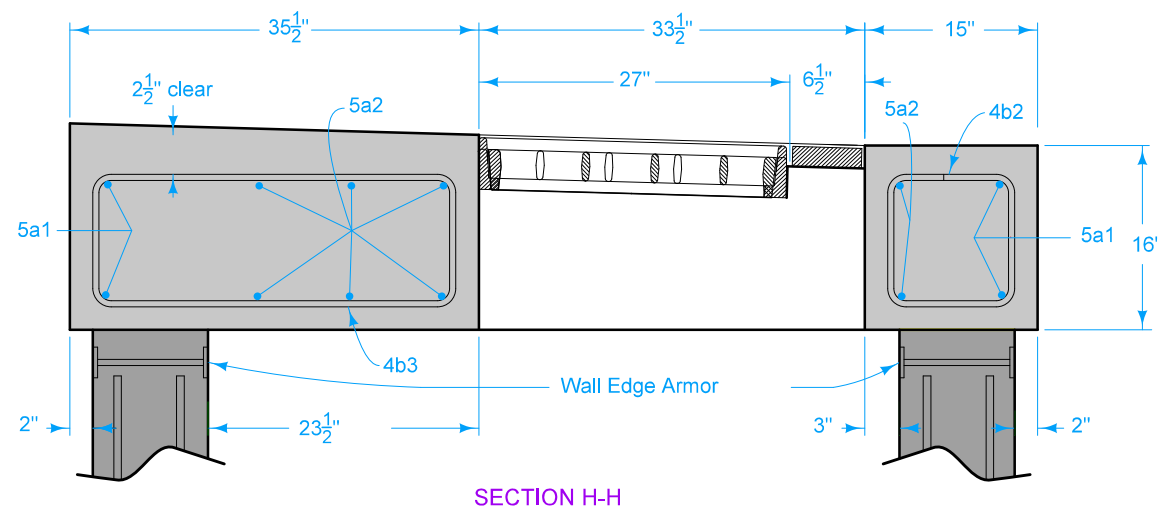
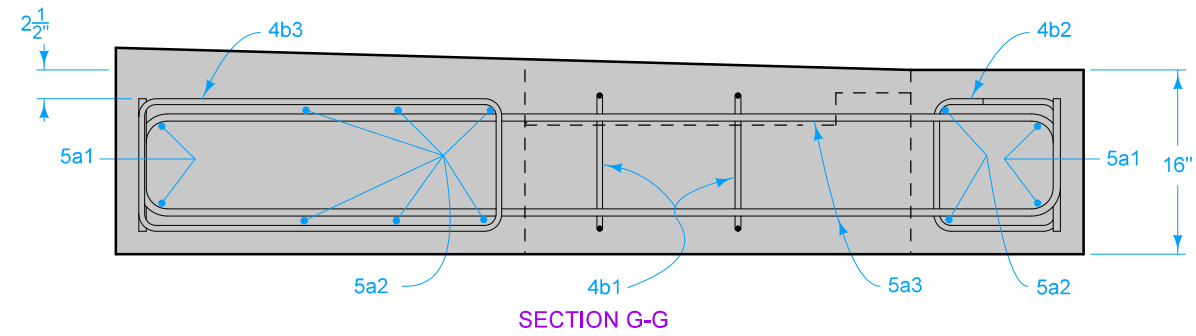

LID REINFORCING BAR LIST					
EPOXY-COATED					
BAR	LOCATION	SHAPE	NO.	LENGTH	WEIGHT (lb.)
5a1	Lid, Exterior, Edge	U	4	16'-5	68
5a2	Lid, Interior, Longitudinal	U	8	9'-0	75
5a3	Lid, Interior, Transverse	U	8	8'-4	70
4b1	Lid Hoop	U	4	5'-11	16
4b2	Lid Hoop	U	3	4'-7	9
4b3	Lid Hoop	U	5	8'-0	27
EPOXY COATED REINFORCING STEEL - TOTAL					265

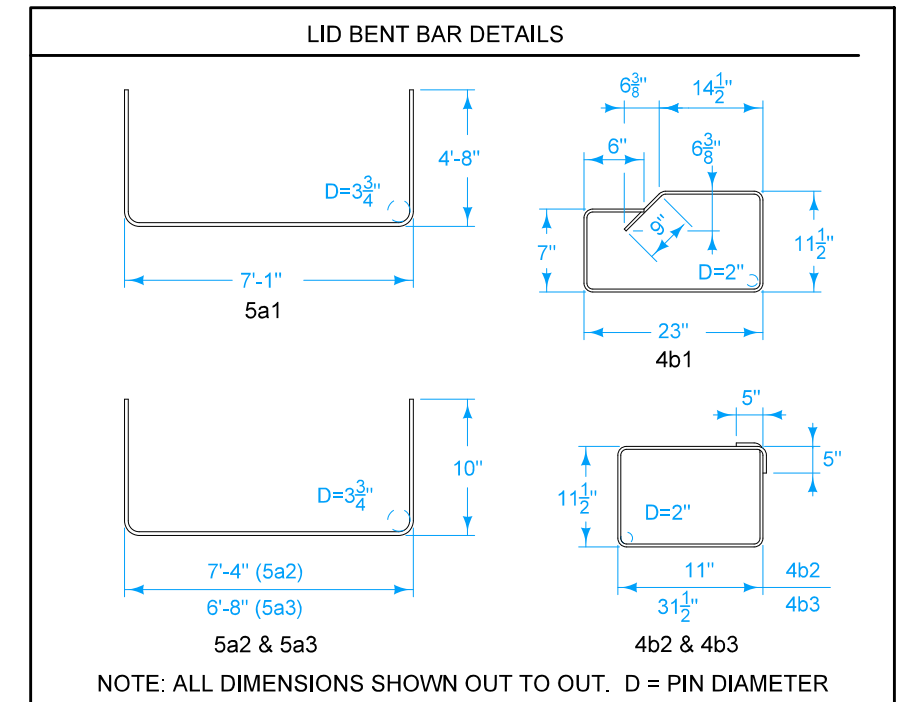

	REVISION
	5 04-17-18
STANDARD ROAD PLAN	SW-549
REVISIONS: Changed 'invert' callout to 'Concrete Filet'. Added maximum pipe diameter.	SHEET 4 of 5
 APPROVED BY DESIGN METHODS ENGINEER	
SINGLE-GRATE BARRIER INTAKE, RECTANGULAR	

LID

VARIABLE DIMENSIONS AND QUANTITIES

Dimensions				Bar List																Quantities								
"H" (Ft.)	"A" (In.)	"E" (In.)	"F" (In.)	4c1		4c2		4c3 (7)		4c4 (7)		4d1				4d2				Concrete - Cu. Yds.				Steel (8)				
				NO.	L	NO.	L	No. of Spaces		NO.	L	No. of Spaces		NO.	L	SP	"K"	NO.	L	SP	"N"	NO.	L	BASE	LID	WALLS	TOTAL	TOTAL LBS.
								"B"	"C"			"B"	"C"															
3	6	3"	7 1/2"	20	4'-3"	--	--	2	--	16	7'-8"	2	--	8	15'-0"	9"	6	14	13'-5"	9"	5	16	6'-10"	1.9	2.2	2.2	6.3	682
4	6	3"	7 1/2"	20	4'-3"	44	3'-10"	3	--	20	7'-8"	3	--	10	15'-0"	9"	6	14	13'-5"	9"	5	16	6'-10"	1.9	2.2	2.9	7.0	835
5	6	3"	7 1/2"	20	4'-3"	44	4'-10"	4	--	24	7'-8"	4	--	12	15'-0"	9"	6	14	13'-5"	9"	5	16	6'-10"	1.9	2.2	3.6	7.7	905
6	6	3"	7 1/2"	20	4'-3"	44	5'-10"	5	--	28	7'-8"	5	--	14	15'-0"	9"	6	14	13'-5"	9"	5	16	6'-10"	1.9	2.2	4.3	8.4	974
7	6	3"	7 1/2"	20	4'-3"	44	6'-10"	6	--	32	7'-8"	6	--	16	15'-0"	9"	6	14	13'-5"	9"	5	16	6'-10"	1.9	2.2	5.0	9.1	1,045
8	6	3"	7 1/2"	20	4'-3"	44	7'-10"	7	--	36	7'-8"	7	--	18	15'-0"	9"	6	14	13'-5"	9"	5	16	6'-10"	1.9	2.2	5.8	9.9	1,114
9	6	3"	7 1/2"	20	4'-3"	44	8'-10"	8	--	40	7'-8"	8	--	20	15'-0"	9"	6	14	13'-5"	9"	5	16	6'-10"	1.9	2.2	6.5	10.6	1,185
10	6	3"	7 1/2"	20	4'-3"	44	9'-10"	9	--	44	7'-8"	9	--	22	15'-0"	9"	6	14	13'-5"	9"	5	16	6'-10"	1.9	2.2	7.2	11.3	1,254
11	6	2"	6"	20	4'-3"	44	10'-10"	10	--	48	7'-8"	10	--	24	15'-0"	8"	7	16	13'-5"	8"	6	18	6'-10"	1.9	2.2	7.9	12.0	1,351
12	6	2"	6"	20	4'-3"	44	11'-10"	11	--	52	7'-8"	11	--	26	15'-0"	8"	7	16	13'-5"	8"	6	18	6'-10"	1.9	2.2	8.6	12.7	1,422
13	6	2"	6"	20	4'-3"	44	12'-10"	12	--	56	7'-8"	12	--	28	15'-0"	8"	7	16	13'-5"	8"	6	18	6'-10"	1.9	2.2	9.4	13.5	1,492
14	6	2"	6"	20	4'-3"	44	13'-10"	13	--	60	7'-8"	13	--	30	15'-0"	8"	7	16	13'-5"	8"	6	18	6'-10"	1.9	2.2	10.1	14.2	1,562
15	9	2"	6"	20	4'-3"	44	14'-10"	13	1	64	7'-8"	13	1	32	15'-0"	8"	7	16	13'-5"	8"	6	18	6'-10"	1.9	2.2	10.8	14.9	1,632
16	12	2"	6"	20	4'-3"	44	15'-10"	13	2	68	7'-8"	13	2	34	15'-0"	8"	7	16	13'-5"	8"	6	18	6'-10"	1.9	2.2	11.5	15.6	1,701
17	6	2"	6"	20	4'-3"	44	16'-10"	13	4	76	7'-8"	13	4	38	15'-0"	8"	7	16	13'-5"	8"	6	18	6'-10"	1.9	2.2	12.2	16.3	1,812
18	9	2"	6"	20	4'-3"	44	17'-10"	13	5	80	7'-8"	13	5	40	15'-0"	8"	7	16	13'-5"	8"	6	18	6'-10"	1.9	2.2	13.0	17.1	1,882
19	12	2"	6"	20	4'-3"	44	18'-10"	13	6	84	7'-8"	13	6	42	15'-0"	8"	7	16	13'-5"	8"	6	18	6'-10"	1.9	2.2	13.7	17.8	1,952
20	6	2"	6"	20	4'-3"	44	19'-10"	13	8	92	7'-8"	13	8	46	15'-0"	8"	7	16	13'-5"	8"	6	18	6'-10"	1.9	2.2	14.4	18.5	2,062
21	9	2"	6"	20	4'-3"	44	20'-10"	13	9	96	7'-8"	13	9	48	15'-0"	8"	7	16	13'-5"	8"	6	18	6'-10"	1.9	2.2	15.1	19.2	2,132
22	12	2"	6"	20	4'-3"	44	21'-10"	13	10	100	7'-8"	13	10	50	15'-0"	8"	7	16	13'-5"	8"	6	18	6'-10"	1.9	2.2	15.8	19.9	2,202
23	6	2"	6"	20	4'-3"	44	22'-10"	13	12	108	7'-8"	13	12	54	15'-0"	8"	7	16	13'-5"	8"	6	18	6'-10"	1.9	2.2	16.6	20.7	2,312
24	9	2"	5 1/2"	20	4'-3"	44	23'-10"	13	13	112	7'-8"	13	13	56	15'-0"	7"	8	18	13'-5"	7"	7	20	6'-10"	1.9	2.2	17.3	21.4	2,410
25	12	2"	5 1/2"	20	4'-3"	44	24'-10"	13	14	116	7'-8"	13	14	58	15'-0"	7"	8	18	13'-5"	7"	7	20	6'-10"	1.9	2.2	18.0	22.1	2,479
26	6	2"	5 1/2"	20	4'-3"	44	25'-10"	13	16	124	7'-8"	13	16	62	15'-0"	7"	8	18	13'-5"	7"	7	20	6'-10"	1.9	2.2	18.7	22.8	2,589
27	9	2"	5 1/2"	20	4'-3"	44	26'-10"	13	17	128	7'-8"	13	17	64	15'-0"	7"	8	18	13'-5"	7"	7	20	6'-10"	1.9	2.2	19.4	23.5	2,660
28	12	2"	5 1/2"	20	4'-3"	44	27'-10"	13	18	132	7'-8"	13	18	66	15'-0"	7"	8	18	13'-5"	7"	7	20	6'-10"	1.9	2.2	20.2	24.3	2,729

- (6) A = First bar spacing at top of wall. Minimum spacing is 3 inches. Maximum spacing is 12 inches. Adjust as necessary.
- (7) See Section A-A on sheet 2 for spacing.
- (8) Quantity includes 265 lbs. for lid.

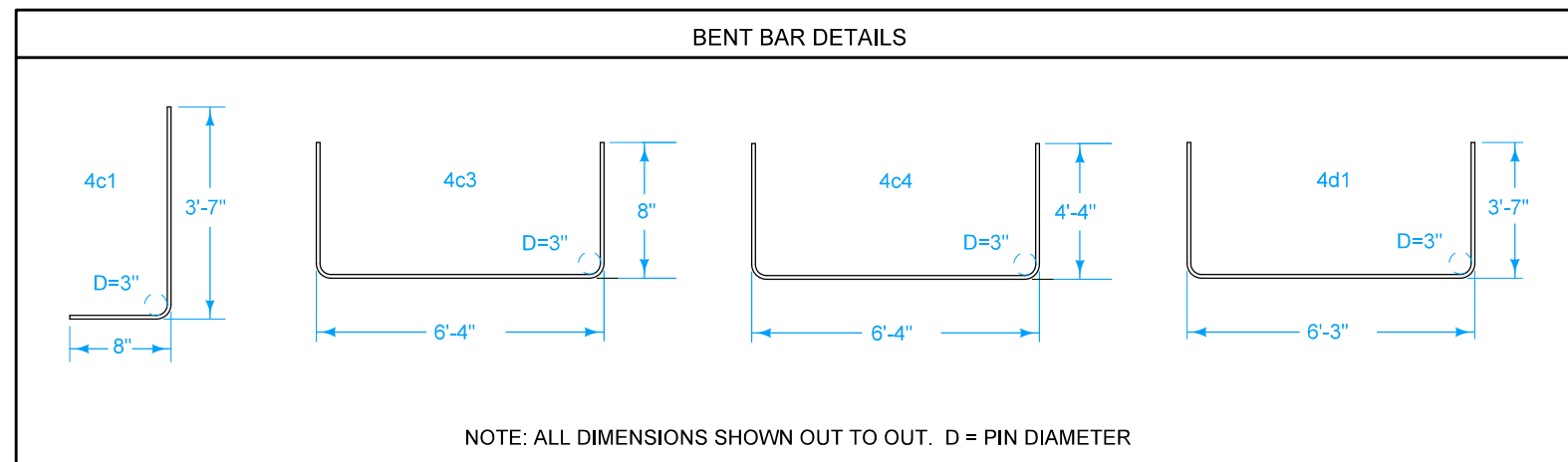

REINFORCEMENT

IOWA DOT	REVISION	
	5	04-17-18
STANDARD ROAD PLAN		SW-549
REVISIONS: Changed 'Invert' callout to 'Concrete Fillet'. Added maximum pipe diameter.		SHEET 5 of 5
 APPROVED BY DESIGN METHODS ENGINEER		

**SINGLE-GRATE BARRIER INTAKE,
RECTANGULAR**