

PLAN OF TOP

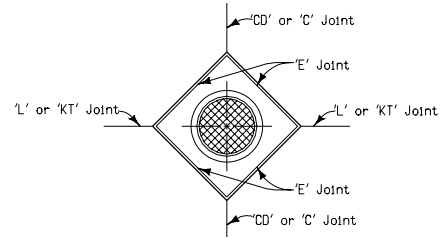

JOINTING LAYOUT IN PCC PAVEMENT

Where the utility access is intersected by the longitudinal and transverse joints.

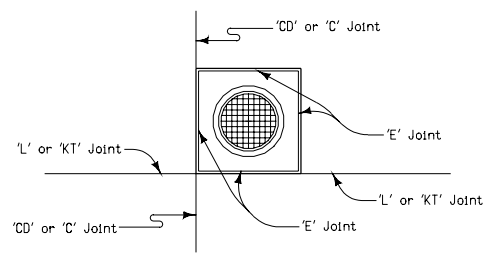

JOINTING LAYOUT IN PCC PAVEMENT

Where the utility access is offset from the longitudinal and transverse joints

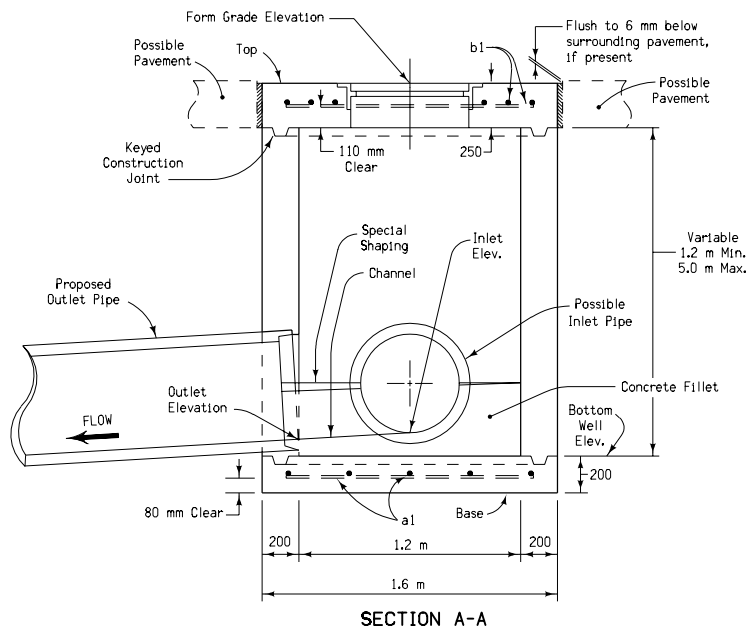

SECTION A-A

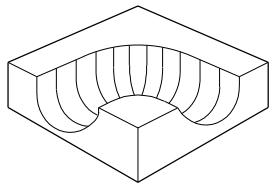

PERSPECTIVE VIEW OF CONCRETE FILLET

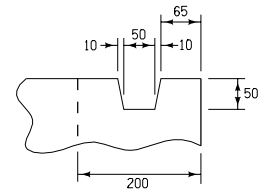

KEYED CONSTRUCTION JOINT DETAIL

REINFORCING BAR LIST							
MARK	SIZE	LOCATION	SHAPE	NO.	LENGTH	MASS	SPACING
a1	15	Base	—	10	1340	21 kg	330
b1	15	Top	—	12	1340	25 kg	130
						Total	46 kg

GENERAL NOTES:
This detail illustrates the construction and installation of a P.C. concrete storm sewer utility access.

All reinforcing bars shall be ASTM A 615, Grade 400.

Precast concrete units with these dimensions may be utilized. The Contractor shall be responsible for any additional reinforcement necessary to prevent cracking during transportation and installation.

If unit is cast in place, storm sewer pipe shall be installed before utility access sidewall construction is started. Sidewalls shall be constructed as indicated with openings for storm sewer pipe(s) smoothly shaped and inlet pipe(s) not projecting unnecessarily into well. Outlet pipe(s) shall not project beyond inside face of sidewall. Storm sewer pipe locations shown hereon are typical. Refer to detail project plans for exact locations.

A concrete fillet shall be placed in the bottom of the utility access approximately as indicated. Special shaping of this fillet is required to provide a smooth channel through the utility access. Top surface of the fillet shall slope at a rate of approximately 12:1 (Horizontal: Vertical) toward the channel.

Finish of the utility access top or any exposed portion shall be as required for "Structural Concrete" in current Standard Specifications.

Joints in pavement adjacent to utility access shall be as shown on Standard Road Plans RH-50, RH-51, and RH-52. Joint locations shall be as indicated hereon except where specifically modified by other plan drawings or by the Engineer.

Price bid for "Utility Access, RA-49" shall include:

- A. All necessary excavation and backfill.
- B. Satisfactory connection to new or existing storm sewer as per detail plans. Connections to precast units shall be as grouted.
- C. Furnishing all materials and constructing utility access as detailed hereon.
- D. Fillet.

Placing Sequence: 1. Base; 2. Walls; 3. Top.

① Use Standard Road Plan RA-54 Type 1 Frame and Cover in areas subject to traffic; when not subject to traffic, use RA-55 Type 1 Frame and Cover.

All dimensions given in millimeters unless noted.

METRIC VERSION	M Iowa Department of Transportation Highway Division	
	STANDARD ROAD PLAN RA-49	
	REVISION: Deleted "If required" in note D.	REVISION NO. 2
	<i>William J. Steen</i> APPROVED BY DESIGN METHODS ENGINEER	REVISION DATE 10-21-03
UTILITY ACCESS		