

PLAN VIEW
LONG CONE

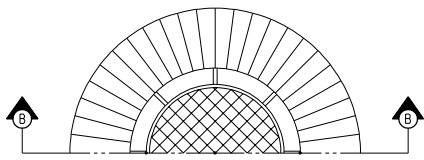

PLAN VIEW
SHORT CONE

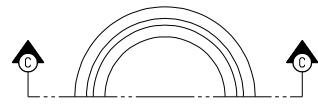

PLAN VIEW
ADJUSTMENT RING

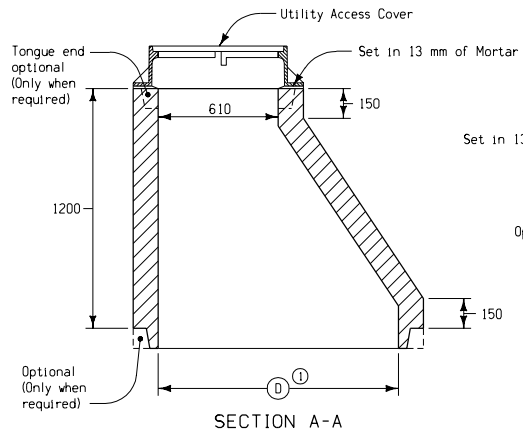

SECTION A-A

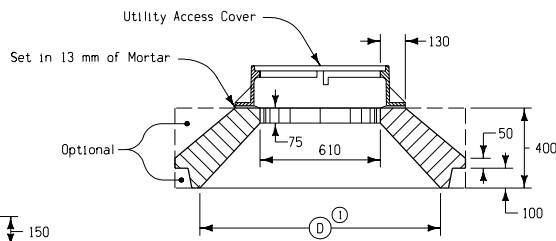

SECTION B-B

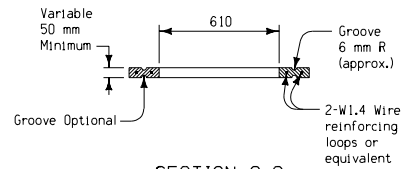

SECTION C-C

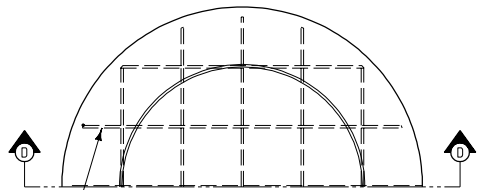

PLAN VIEW - PRECAST BASE
FOR UTILITY ACCESS

#10 Reinforcing bars spaced at 300 mm centers each direction (or equivalent)

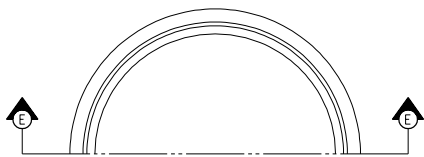

PLAN VIEW
SPACER

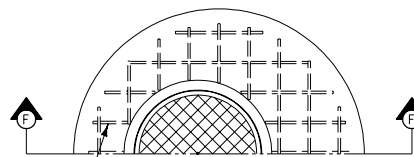

PLAN VIEW
SLAB TOP

#10 Reinforcing bars spaced at 150 mm centers each direction (or equivalent)

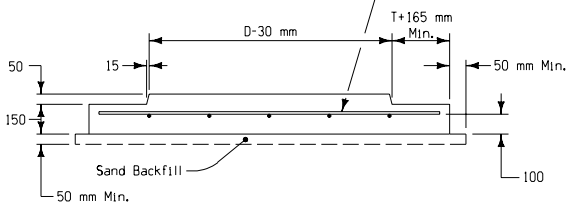

SECTION D-D

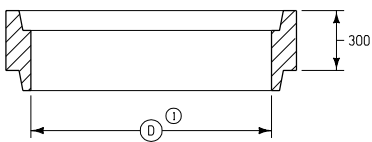

SECTION E-E

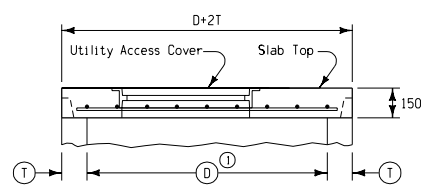

SECTION F-F

GENERAL NOTES:

This sheet illustrates the general requirements for the fabrication of the accessory units used in conjunction with utility access installations. Alternate designs for the units shown may be submitted to the Engineer for approval. Refer to detail project plans for details of requirements for individual installations. Also refer to Standard Road Plan RF-1.

Materials and methods of construction shall be in accordance with current Standard and Supplemental Specifications.

Dimensions shown shall apply unless modified by plan requirements of individual project installations.

Units may be used as necessary to accomplish plan requirements for utility access elevations, dimensions, etc.

The Long Cone shall be of the eccentric design shown, unless otherwise specifically required on project plans. The Short Cone shall only be of the concentric design shown.

Reinforcing in Long Cone, Short Cone and Spacer shall be at least equivalent in cross sectional area to the reinforcing required for cylindrical utility access sections.

The Long Cone and Short Cone may be used where necessary, whether utility access would be subject to roadway traffic or not. The Slab Top shall not be used where the installation would be subject to roadway traffic.

Where any utility access unit is installed in a location subject to roadway traffic, Standard Road Plan RA-54 (Type 1 or Type 2) utility access cover is required. In locations where utility cover is not subject to roadway traffic, Standard Road Plan RA-55 (Type 1 or Type 2) utility access cover may be used, unless specified otherwise in detail project plans.

Normally, the Type 1 utility access cover will be used for the Slab Top and the Type 2 cover will be used for the Long or Short Cone. Refer to Standard Road Plans RA-54 and RA-55 for details of covers.

Where precast bases are used, all materials excavated below the required elevation of the base shall be replaced with a sand backfill. A minimum of 50 millimeters of sand backfill is required under all precast bases. Sand backfill used will be considered incidental to utility access construction.

All plan views are symmetrical about section line.

① 1200 millimeters maximum.

All dimensions given in millimeters unless noted.

METRIC VERSION	Iowa Department of Transportation	
	Project Development Division	
	STANDARD ROAD PLAN	RA-53
	REVISION: Correct typographical errors.	
	<i>David P. Smith</i>	06-23-97
	APPROVED BY DESIGN METHODS ENGINEER	
	REVISION NO.	1
	REVISION DATE	10-28-97
DETAILS OF ACCESSORY UNITS FOR CONCRETE UTILITY ACCESSES		