

Price bid for "Intake for Bridge End Drain, SW-538" is full compensation for furnishing, installing, and constructing the Bridge End Drain as shown.

- ① Refer to BR-201, BR-202, BR-203, BR-204, or BR-205 for details of 4 inch sloped curb.
- ② Continue 4 inch Sloped Curb 5 feet beyond centerline of intake, then transition to no curb as shown on PV-102.
- ③ Install modified subbase and polymer grid under P.C.C. shoulder panels. See Section A-A (BR-201, BR-202, BR-203, or BR-204, or BR-205) or Section C-C (BR-231).
- ④ DI-1 and DI-2 distances measured from center of bolt hole pattern. Locate center of intake 6 feet or more from the nearest transverse pavement joint and between guardrail posts to allow for storm sewer outlet. Joints are determined by the bridge approach section.

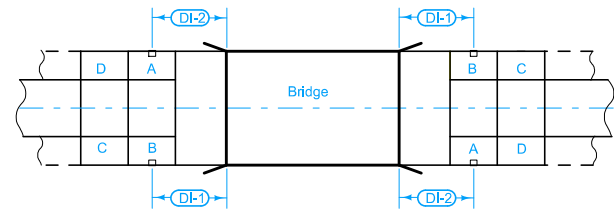

PCC SHOULDER PANEL LOCATIONS  
(Non-Skewed Bridge)

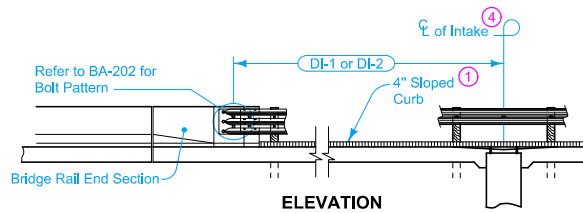
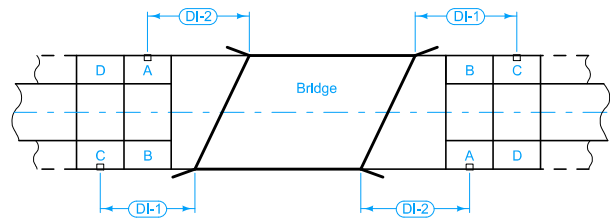
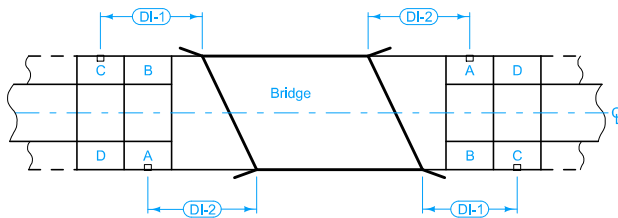

PCC SHOULDER PANEL LOCATIONS  
(Skewed Bridge)

- Possible Contract Items:  
 Intake for Bridge End Drain, SW-538  
 Paved Shoulder, Portland Cement Concrete (Paved Shoulder Panel for Bridge-End Drain)
- Incidental to Paved Shoulder:  
 Modified Subbase  
 Polymer Grid
- Possible Tabulation:  
 104-8

|  |              |
|--|--------------|
|  | REVISION     |
|  | 3   10-15-19 |
| STANDARD ROAD PLAN   | SW-538       |
| SHEET 1 of 5   |              |
| REVISIONS: Added BR-205 to Circle Notes, 1 & 3. Changed corrugated metal pipe to high density polyethylene (HDPE) pipe on Sheet 2. |              |
| APPROVED BY DESIGN METHODS ENGINEER  |              |
| INTAKE FOR BRIDGE END DRAIN  |              |

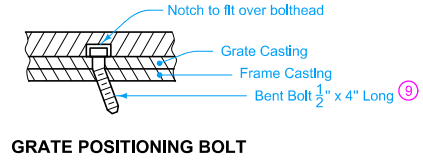
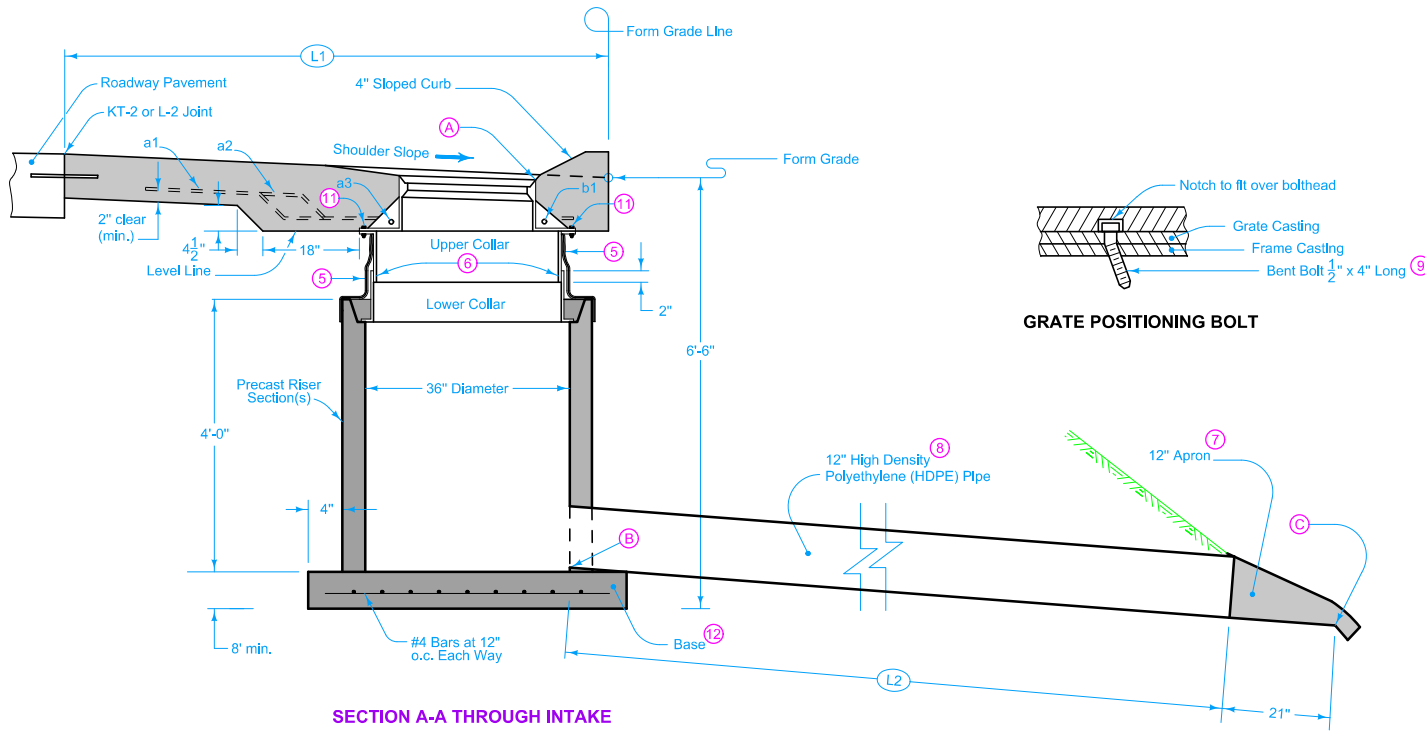

SECTION A-A THROUGH INTAKE

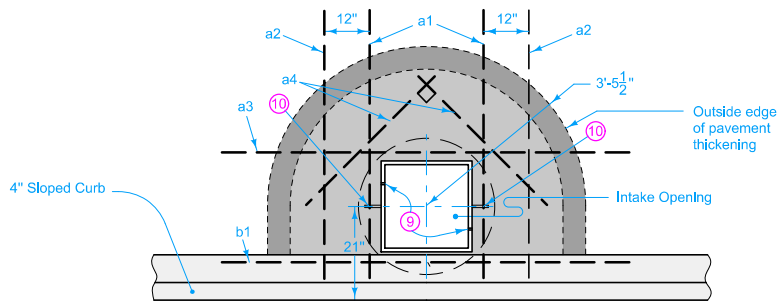

REINFORCING LAYOUT

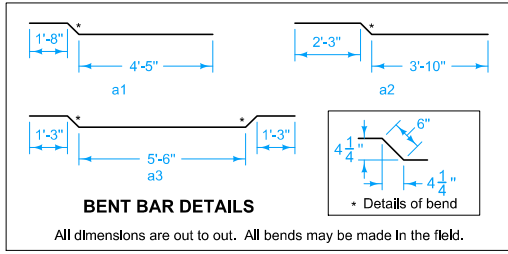

| REINFORCING BAR LIST |      |          |       |     |        |         |
|----------------------|------|----------|-------|-----|--------|---------|
| MARK                 | SIZE | LOCATION | SHAPE | NO. | LENGTH | WEIGHT  |
| a1 (10)              | 4    | Shoulder | ~     | 2   | 6'-7"  | 9       |
| a2                   | 4    | Shoulder | ~     | 2   | 6'-7"  | 9       |
| a3 (10)              | 4    | Shoulder | ~     | 1   | 9'-0"  | 6       |
| a4                   | 4    | Shoulder | ~     | 2   | 4'-0"  | 5       |
| b1 (10)              | 4    | Curb     | ~     | 1   | 8'-9"  | 6       |
| Total                |      |          |       |     |        | 35 lbs. |

Construct precast base using 4 in. x 4 in. No. 6 steel wire mesh reinforcing or equivalent.

To ensure water-tight joints, use an approved asphaltic sealer for all corrugated metal pipe joints constructed using connecting bands.

Flow line (A) elevation is 0.10 feet below Form Grade Elevation.

Flow line (B) elevation is 5.75 feet below flow line (A).

Flow line (C) elevation is 0 - 0.5 feet above ditch grade.

Refer to project plans for actual flow line elevations of (A), (B), (C), and dimensions L1 and L2.

(5) Before backfilling around the intake assembly, wrap two thicknesses of engineering fabric around the settlement collar. Tape all the way around with 2 inch duct tape immediately below the flange of upper section and 4 inches below the top of well pipe.

(6) Fasten Slip joint temporarily with four 1/2 inch cap screws during pavement construction. Remove cap screws after pavement is hardened.

(7) Refer to DR-203. Apron is incidental to Intake for Bridge End Drain and will not be paid for separately.

(8) Connect to basin according to Section 2435 of the Standard Specifications. High Density Polyethylene (HDPE) Pipe is incidental to Intake for Bridge End Drain and will not be paid for separately.

(9) Field place 1/2 in. x 4 in. long bolt in upstream side and bend underside to prevent removal.

(10) Place bars a1, a3, and b1 through the appropriate holes in the intake frame.

(11) Fasten frame casting to Upper Collar casting at four locations using 1/2 in. x 2 in. long hex bolts and 1/2 inch nuts.

(12) Cast-in-place base shown. Base may be square. If base is precast integral with walls, the footprint of the base is not required to extend beyond the outer edge of the walls.

|  |                          |
|--|--------------------------|
| <br><b>STANDARD ROAD PLAN</b>  | REVISION<br>3   10-15-19 |
|  | <b>SW-538</b>            |
|  | SHEET 2 of 5             |
| REVISIONS: Added BR-205 to Circle Notes: 1 & 3. Changed corrugated metal pipe to high density polyethylene (HDPE) pipe on Sheet 2. |                          |
| <br>APPROVED BY DESIGN METHODS ENGINEER  |                          |
| <b>INTAKE FOR BRIDGE END DRAIN</b>   |                          |

Minimum Weight = 90 lbs.

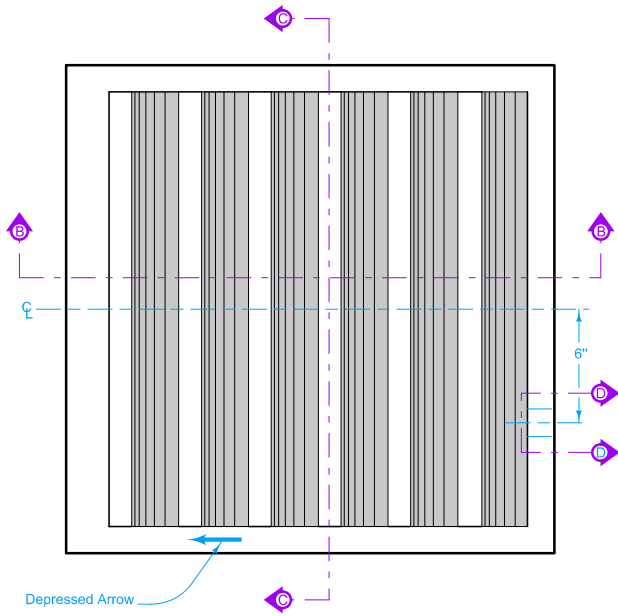

PLAN

← Flow

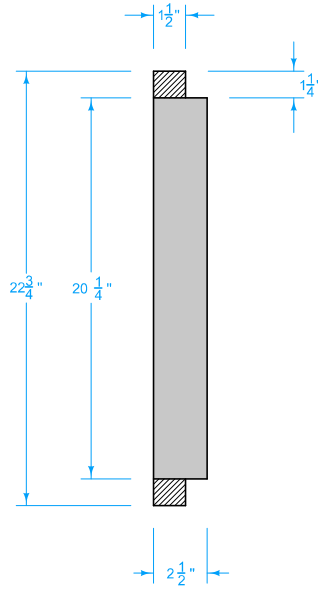

SECTION C-C

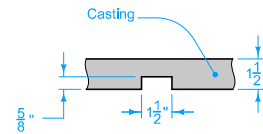

SECTION D-D

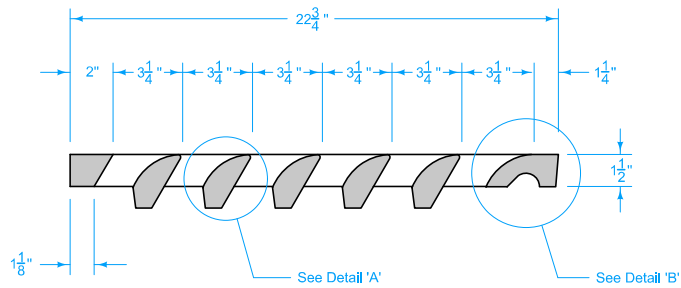

SECTION B-B

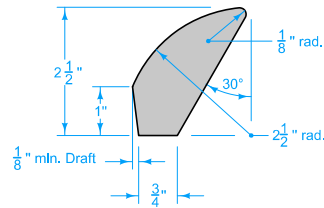

DETAIL 'A'

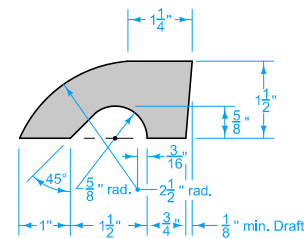

DETAIL 'B'

GRATE

|   |                           |               |
|---|---------------------------|---------------|
|   | REVISION                  | 10-15-19      |
|   | 3                         |               |
|   | <b>STANDARD ROAD PLAN</b> |               |
| REVISIONS: Added BR-205 to Circle Notes 1 & 3. Changed corrugated metal pipe to high density polyethylene (HDPE) pipe on Sheet 2. |                           | <b>SW-538</b> |
|   |                           | SHEET 3 of 5  |
| APPROVED BY DESIGN METHODS ENGINEER   |                           |               |
| <b>INTAKE FOR BRIDGE END DRAIN</b>  |                           |               |

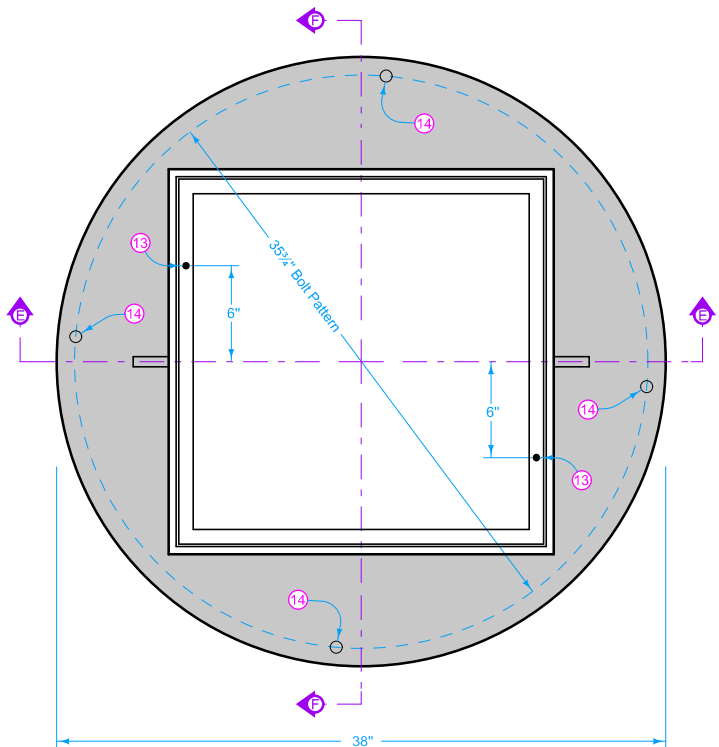

PLAN

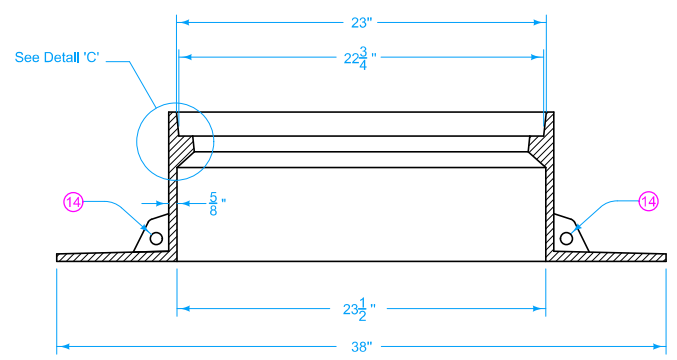

SECTION E-E

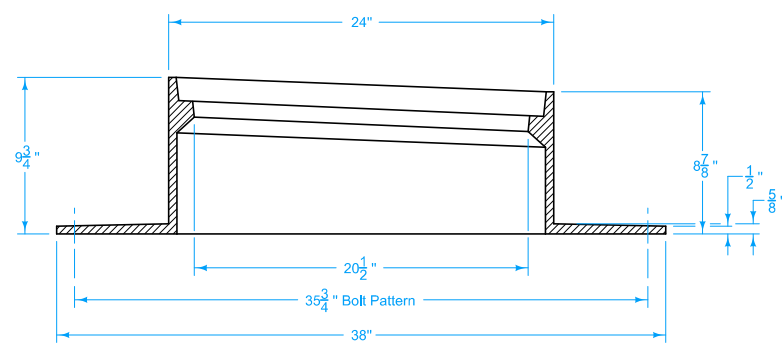

SECTION F-F

FRAME

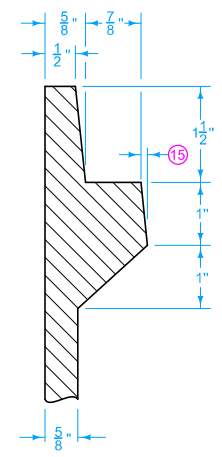

DETAIL 'C'

Minimum Weight = 163 lbs.

- 13 Provide  $\frac{9}{16}$  inch diameter holes at locations indicated.
- 14  $\frac{3}{4}$  inch holes. Drill or core if not already existing.
- 15 DRAFT (Small Casting Taper) will be permitted.

|  |              |
|--|--------------|
|  | REVISION     |
|  | 3 10-15-19   |
| STANDARD ROAD PLAN   | SW-538       |
|  | SHEET 4 of 5 |
| <small>REVISIONS: Added BR-205 to Circle Notes 1 &amp; 3. Changed corrugated metal pipe to high density polyethylene (HDPE) pipe on Sheet 2.</small> |              |
| <small>APPROVED BY DESIGN METHODS ENGINEER</small>   |              |
| <b>INTAKE FOR BRIDGE END DRAIN</b>   |              |

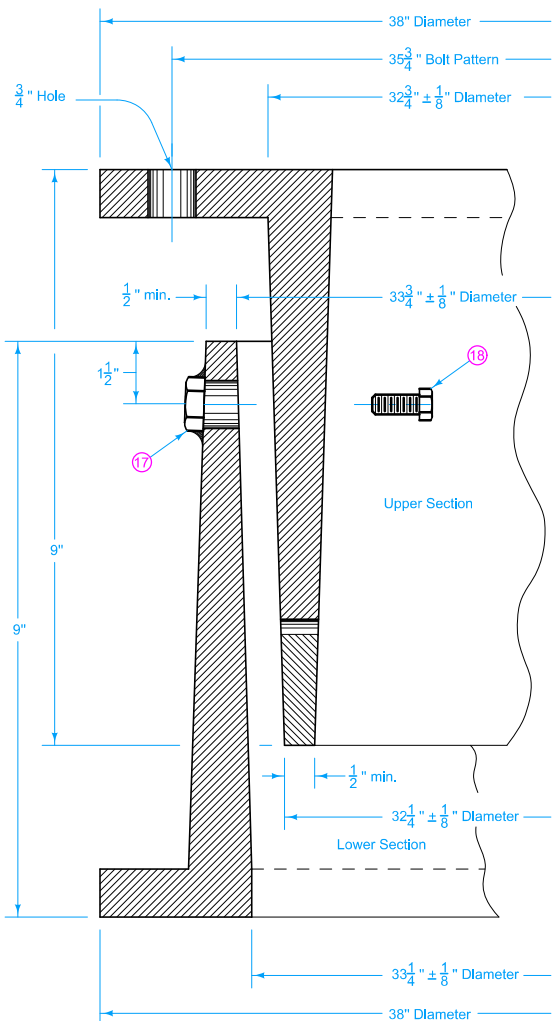

SETTLEMENT COLLAR

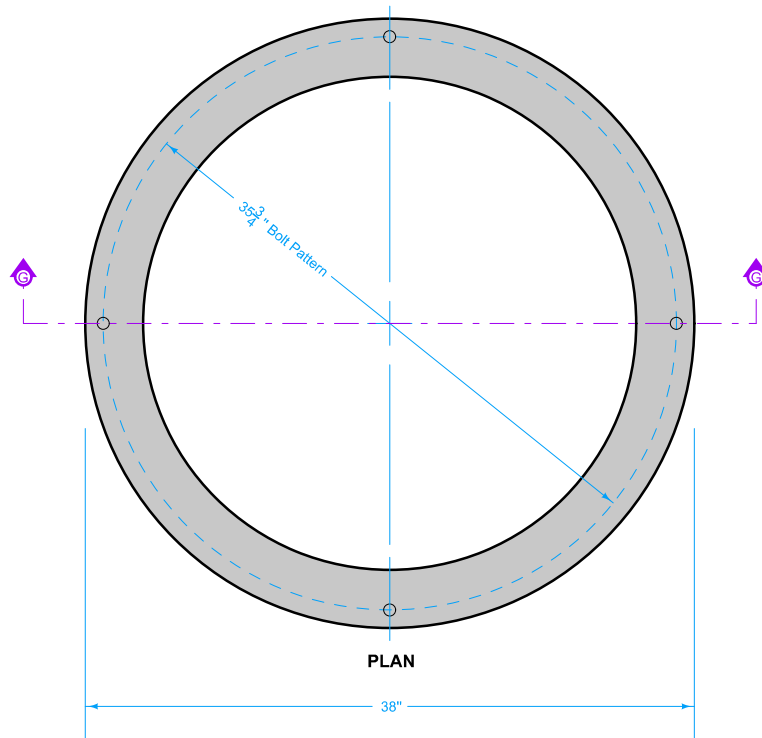

PLAN

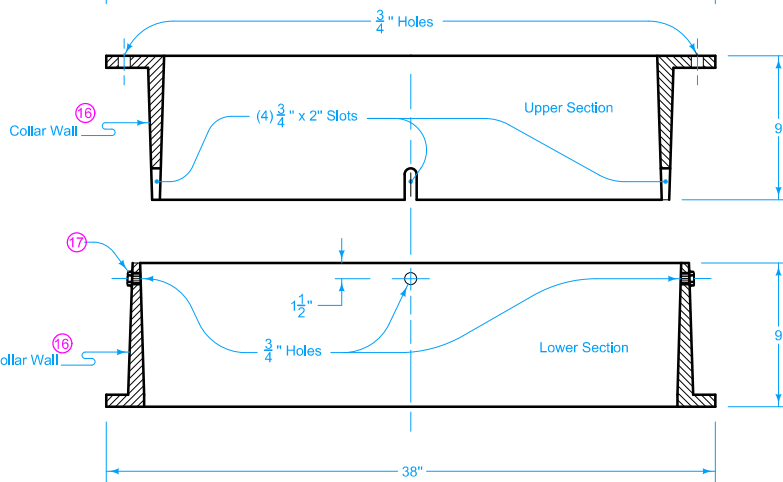

SECTION G-G

- 16 Wall thickness may vary uniformly from base to the top or bottom of the casting.
- 17 Tack weld four  $\frac{1}{2}$  inch nuts to outside of bottom settlement collar or drill and tap four holes for  $\frac{1}{2}$  inch Cap Screws in bottom settlement collar.
- 18 Remove the four  $\frac{1}{2}$  inch Cap Screws after surrounding concrete has set.

| MINIMUM WEIGHT |          |
|----------------|----------|
| Upper Section  | 210 lbs. |
| Lower Section  | 210 lbs. |

|  |               |
|--|---------------|
| <br><b>STANDARD ROAD PLAN</b>  | REVISION      |
|  | 3 10-15-19    |
|  | <b>SW-538</b> |
| SHEET 5 of 5   |               |
| <small>REVISIONS: Added BR-205 to Circle Notes 1 &amp; 3. Changed corrugated metal pipe to high density polyethylene (HDPE) pipe on Sheet 2.</small> |               |
| <small>APPROVED BY DESIGN METHODS ENGINEER</small>   |               |

INTAKE FOR BRIDGE END DRAIN