

PLAN

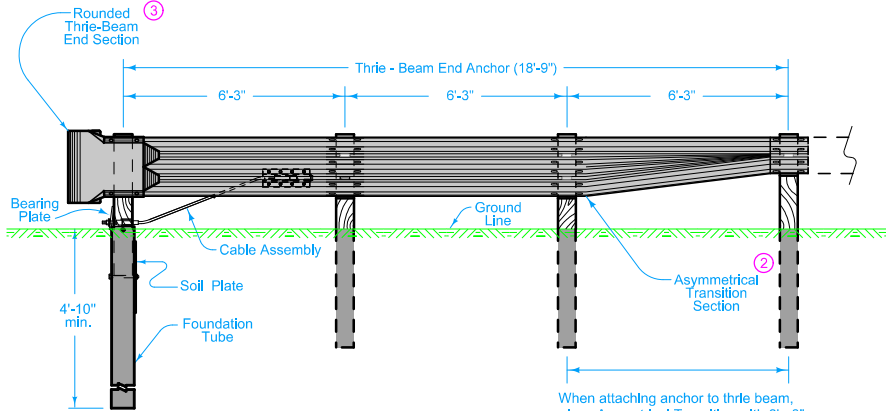

ELEVATION

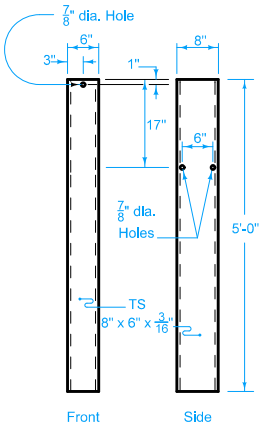

FOUNDATION TUBE

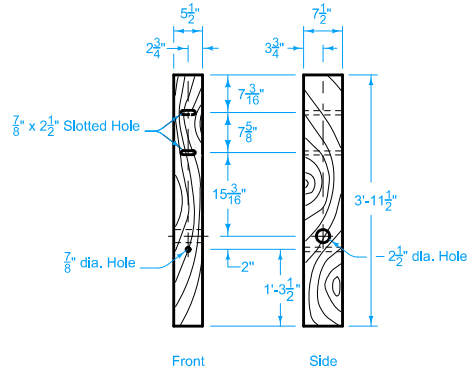

BCT WOOD POST

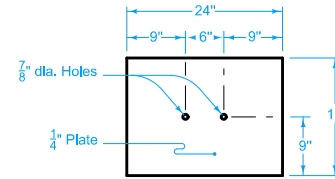

SOIL PLATE

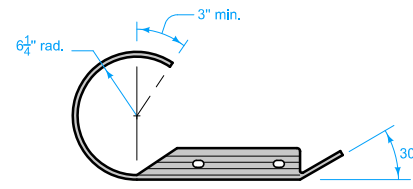

PLAN

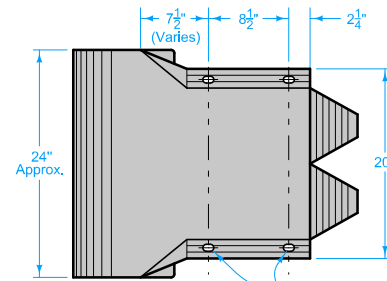

ELEVATION

ROUNDED THRIE-BEAM END SECTION

- ① Slotted holes $\frac{23}{32}$ " x $1\frac{1}{8}$ " long.
- ② Refer to **BA-200**.
- ③ Cover entire face of end section with alternating black and yellow striped adhesive sheeting. Stripes shall be approximately 3 inches in width and shall be sloped down at an angle of 45 degrees toward the side on which traffic is to pass the end anchor. Yellow stripes shall meet the retroreflectivity requirements for Type III or Type IV reflective sheeting.

Possible Contract Item:
Steel Beam Guardrail End Anchor, Thrie-Beam

- Materials included in the Contract Item:
- (1) 12'-6" Thrie-Beam rail section
 - (1) Asymmetrical Transition Section
 - (2) Thrie-Beam posts (wood or steel - match remainder of installation)
 - (1) W-Beam post (wood or steel - match remainder of installation)
 - (1) W-Beam blackout
 - (2) Thrie-Beam blockouts
 - (1) BCT Wood Post
 - (1) Anchor Bracket Assembly
 - (1) Cable Assembly
 - (1) Foundation Tube Assembly with Soil Plate
 - (1) Pipe Sleeve
- Approved bolts, nuts, and washers

IOWA DOT	REVISION	
	2	10-15-19
STANDARD ROAD PLAN	BA-204	
SHEET 1 of 1		

REVISIONS: New Isgo.

Scott Miller
APPROVED BY DESIGN METHODS ENGINEER

**STEEL BEAM GUARDRAIL
THRIE-BEAM END ANCHOR**