

ASSEMBLY DETAIL

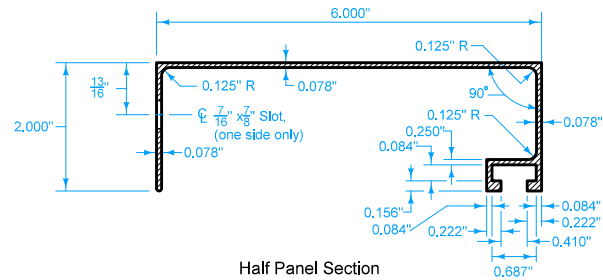

Panel bolt slotted holes spaced at 12 inch centers shall be located along the full length of each panel, such that the outermost slots are of equal distances (not to exceed 6 inches) from the ends of the panel.

Signs shall be made up of full panels unless a half panel is required, in which case it shall be placed at the top edge of the sign.

Refer to detail project plans and summary sheet for exact data for individual sign fabrication requirements.

① Two washers per panel bolt, one each side of sign.

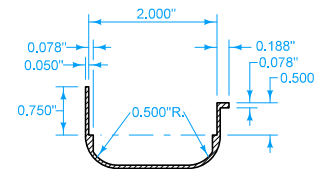

EDGE MOLDING

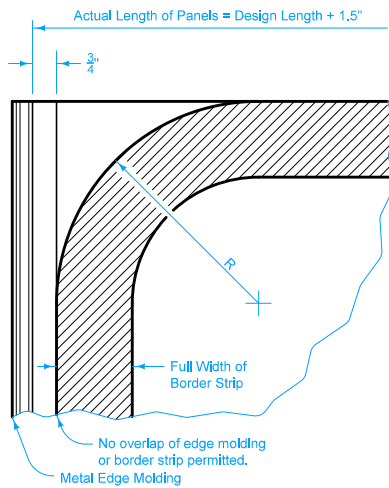

EDGE MOLDING BORDER STRIP DETAIL

Edge molding shall be installed full length of each vertical side of each sign. Attach in accordance with current specifications.

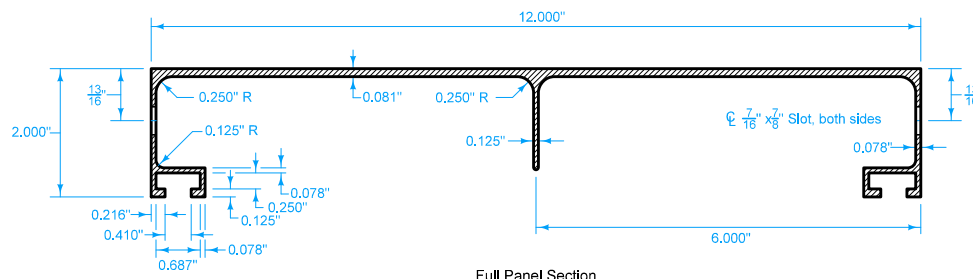

Full Panel Section

STANDARD STRUCTURAL SIGN PANELS

| | | | |
|---|---------------|---|----------|
| STANDARD ROAD PLAN | REVISION | 3 | 10-20-20 |
| | SI-123 | | |
| | SHEET 1 of 1 | | |
| REVISIONS: Modified dimension from 0.78 to 0.078 in Full Panel Section. | | | |
| APPROVED BY DESIGN METHODS ENGINEER | | | |
| FABRICATION - TYPE 'B' SIGNS | | | |