

PLAN  
(SW-542 EXTENSION AND SW-541 INTAKE)

Extension unit may be used on either or both sides of SW-541 intakes. Details are similar when extension unit is on the opposite side.

- ① g3 for 6 inch standard curb; g5 for 4 inch sloped curb.
- ② c1 for 6 inch standard curb; c2 for 4 inch sloped curb. See SW-541 for reinforcing.
- ③ The location station is where the centerline of intake meets the back of the curb line.

Placing sequence: 1. Base; 2. Walls and Extension; 3. Top; 4. Insert

REINFORCING BAR LIST							
BAR	SIZE	LOCATION	SHAPE	NO.	LENGTH	WEIGHT	SPACING
b2	4	Intake Wall		3	2'-6"	5.0	9"
f1	4	Bottom		3	4'-9"	9.5	9"
f2	4	Bottom		4	1'-7"	4.2	18"
g1	4	Wall		5	Varies*	Varies*	12"
g2	4	Wall		1	4'-8"	3.1	-
g3	4	Top		4	Varies**	Varies**	18"
g4	4	Top		3	6'-4"	12.7	-
g5	4	Top		4	Varies**	Varies**	18"

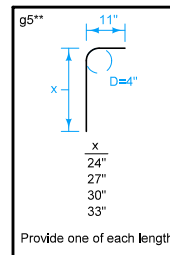
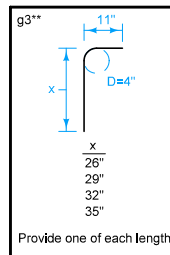
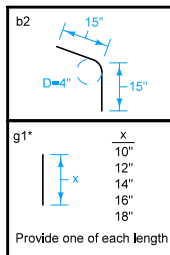
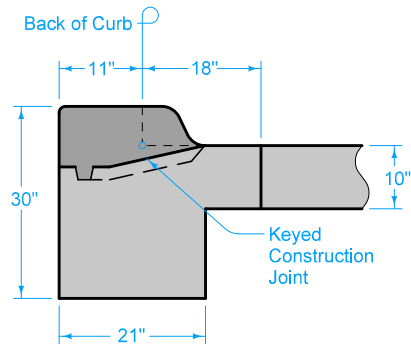
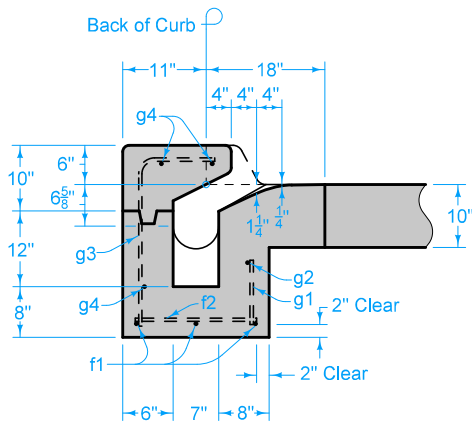

FIGURE 6010.542 SHEET 1 OF 4

	REVISION	5	10-20-20
	FIGURE 6010.542	STANDARD ROAD PLAN	<b>SW-542</b>
REVISIONS: Removed Interim from standard.			SHEET 1 of 4
SUDAS DIRECTOR		DESIGN METHODS ENGINEER	
<b>EXTENSION UNIT FOR OPEN-THROAT CURB INTAKE UNDER PAVEMENT</b>			



SECTION A-A



SECTION B-B

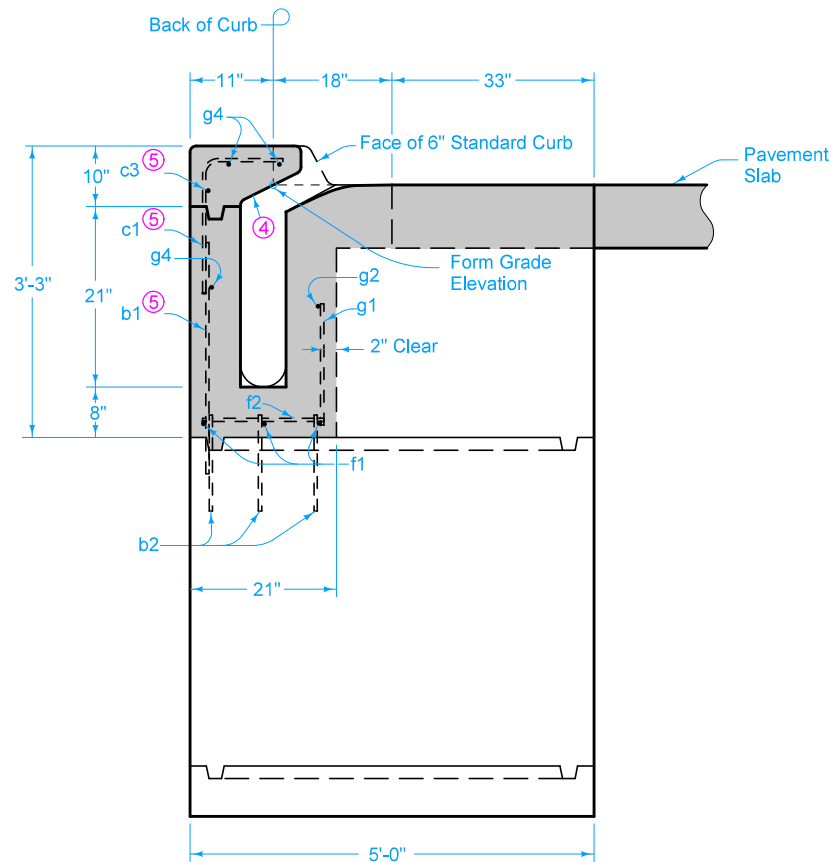

SECTION C-C

- ④ 2:1 Slope (Horizontal:Vertical)
- ⑤ See SW-541 for reinforcing.

6 INCH STANDARD CURB

	REVISION	5	10-20-20
	FIGURE 6010.542	STANDARD ROAD PLAN	<b>SW-542</b>
REVISIONS: Removed Interim from standard.			SHEET 2 of 4
 SUDAS DIRECTOR		 DESIGN METHODS ENGINEER	
<b>EXTENSION UNIT FOR OPEN-THROAT CURB INTAKE UNDER PAVEMENT</b>			

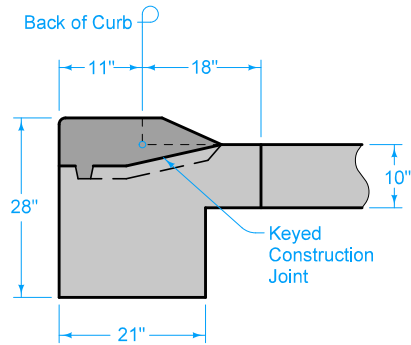

SECTION A-A

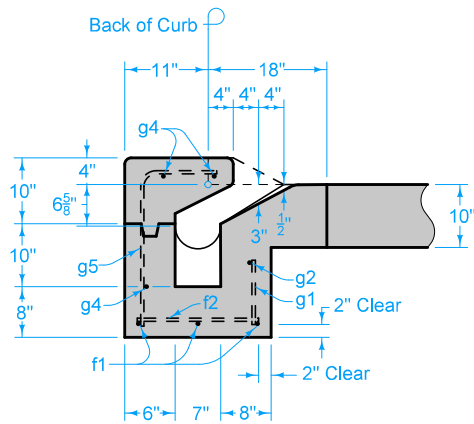

SECTION B-B

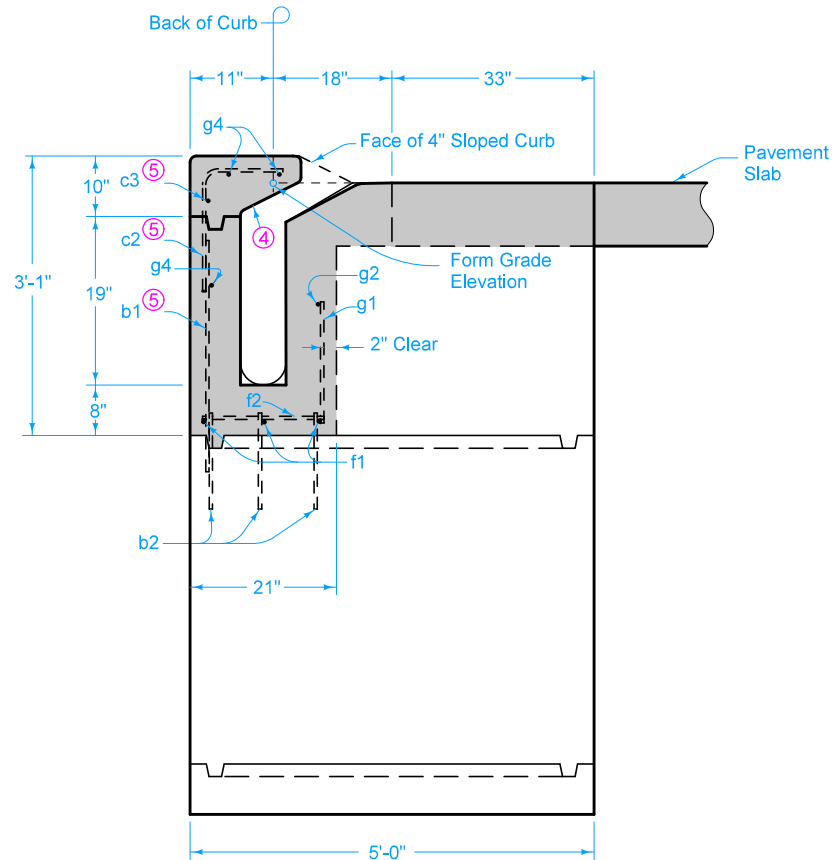

SECTION C-C

- ④ 2:1 Slope (Horizontal:Vertical)
- ⑤ See SW-541 for reinforcing.

4 INCH SLOPED CURB

	REVISION	5	10-20-20
	FIGURE 6010.542	STANDARD ROAD PLAN	<b>SW-542</b>
REVISIONS: Removed Interim from standard.			SHEET 3 of 4
 SUDAS DIRECTOR		 DESIGN METHODS ENGINEER	
<b>EXTENSION UNIT FOR OPEN-THROAT CURB INTAKE UNDER PAVEMENT</b>			

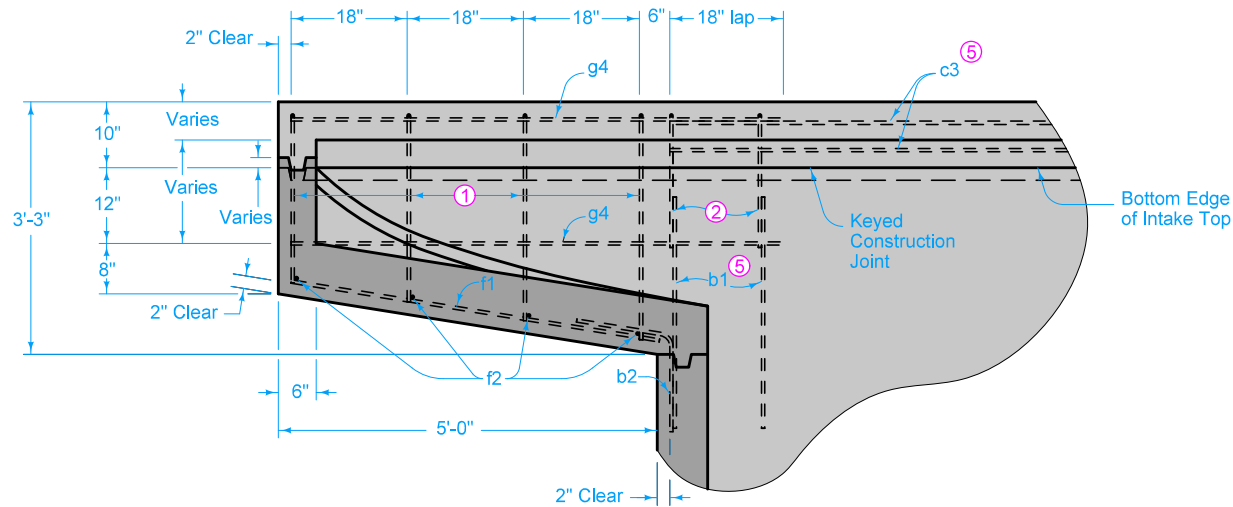

SECTION D-D

- ① g3 for 6 inch standard curb; g5 for 4 inch sloped curb.
- ② c1 for 6 inch standard curb; c2 for 4 inch sloped curb. See SW-541 for reinforcing.
- ⑤ See SW-541 for reinforcing.

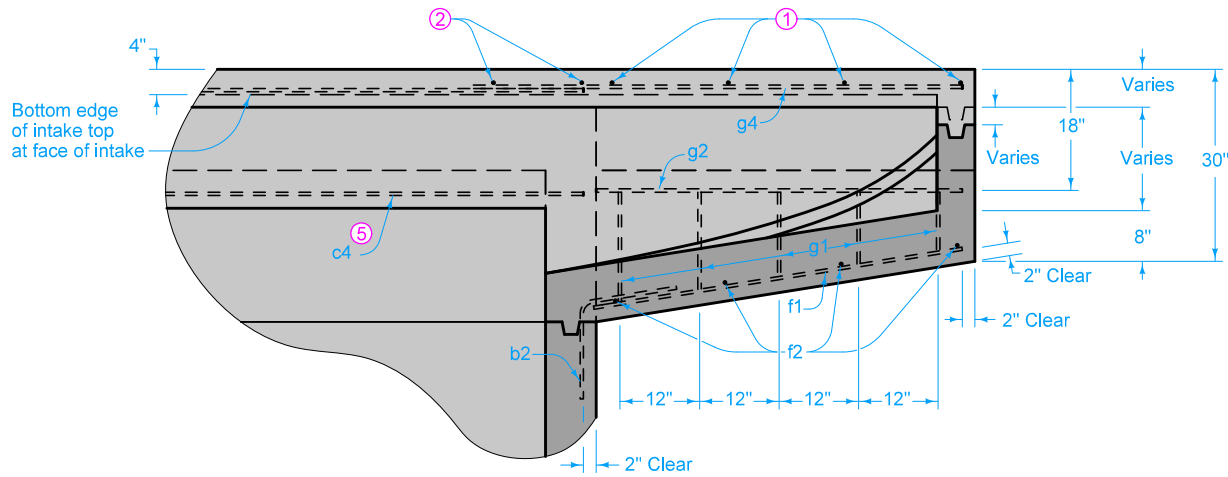

SECTION E-E

FIGURE 6010.542 SHEET 4 OF 4

	REVISION	5	10-20-20
	FIGURE 6010.542	STANDARD ROAD PLAN	<b>SW-542</b>
REVISIONS: Removed Interim from standard.			SHEET 4 of 4
 SUDAS DIRECTOR		 DESIGN METHODS ENGINEER	
<b>EXTENSION UNIT FOR OPEN-THROAT CURB INTAKE UNDER PAVEMENT</b>			