

**MAST ARM POLE FOUNDATION IN SOIL  
TYPE A FOUNDATION**

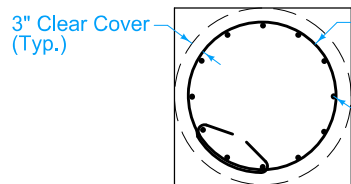

**PLAN VIEW**

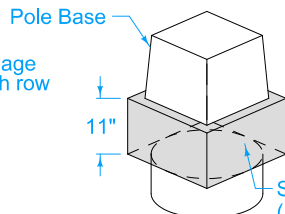

**DETAIL 'A'**

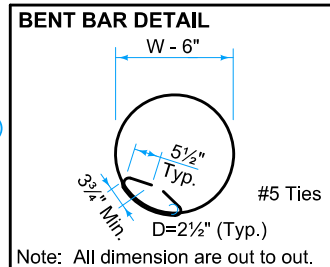

Note: All dimension are out to out.

The Type A Foundation is the normally required foundation construction. Where rock is encountered, the Engineer may approve the use of the Type B or C Foundation. Prior to installing a foundation in rock, obtain a subsurface investigation certified by a geotechnical engineer licensed in the State of Iowa.

- ① Shape top 11 inches with forms. See Detail 'A'.
- ② Install rodent guard or non-shrink grout with weep hole.
- ③ Furnish nut, nut and plate, or nut and anchor bolt assembly ring plate on embedded end.

Max. Mast Arm Length	Foundation		"V" Bars			Tie Bars				
	W	L	Count	Size	Length	Count	Upper Spacing		Lower Spacing	
							# Spaces	S <sub>1</sub>	# Spaces	S <sub>2</sub>
35'-0"	3'-0"	12'-0"	12	#8	11'-6"	17	9	12"	N/A	N/A
45'-0"	3'-0"	14'-0"	12	#8	13'-6"	19	11	12"	N/A	N/A
55'-0"	3'-0"	16'-0"	12	#8	15'-6"	25	12	8"	5	12"
60'-0"	3'-0"	18'-0"	13	#8	17'-6"	28	15	8"	5	12"
70'-0"	3'-6"	18'-0"	12	#10	17'-6"	28	15	8"	5	12"
80'-0"	3'-6"	21'-0"	14	#10	20'-6"	40	22	6"	10	8"
90'-0"	4'-0"	22'-0"	16	#10	21'-6"	42	24	6"	10	8"
100'-0"	4'-0"	24'-0"	18	#10	23'-6"	47	32	6"	7	8"

SUDAS	IOWADOT	REVISION
		4 04-21-20
FIGURE 8010.102	STANDARD ROAD PLAN	<b>TS-102</b>
SHEET 1 of 4		
REVISIONS: Modified conduit details in MAST ARM POLE FOUNDATION drawings on Sheets 1, 2, and 3.		
Paul D. Weigand SUDAS DIRECTOR		Steve Nade DESIGN METHODS ENGINEER
<b>TRAFFIC SIGNAL POLE FOUNDATION</b>		

Type B Foundation is applicable for traffic signal poles with mast arm lengths up to 60 feet.

If the excavation for a Type B Foundation is left open for more than 1 calendar day, install temporary barrier rail if any part of the excavation is located within the clear zone. Temporary barrier rail layout requires the Engineer's approval.

Competent rock has an average unconfined compressive strength ( $q_u$ ) of at least 2.0 ksi and rock quality designation of at least 90%. Conditions not meeting minimum requirements will require either:

- A site specific design, or
- Using the parameters for Mast Arm Pole Foundation in Soil.

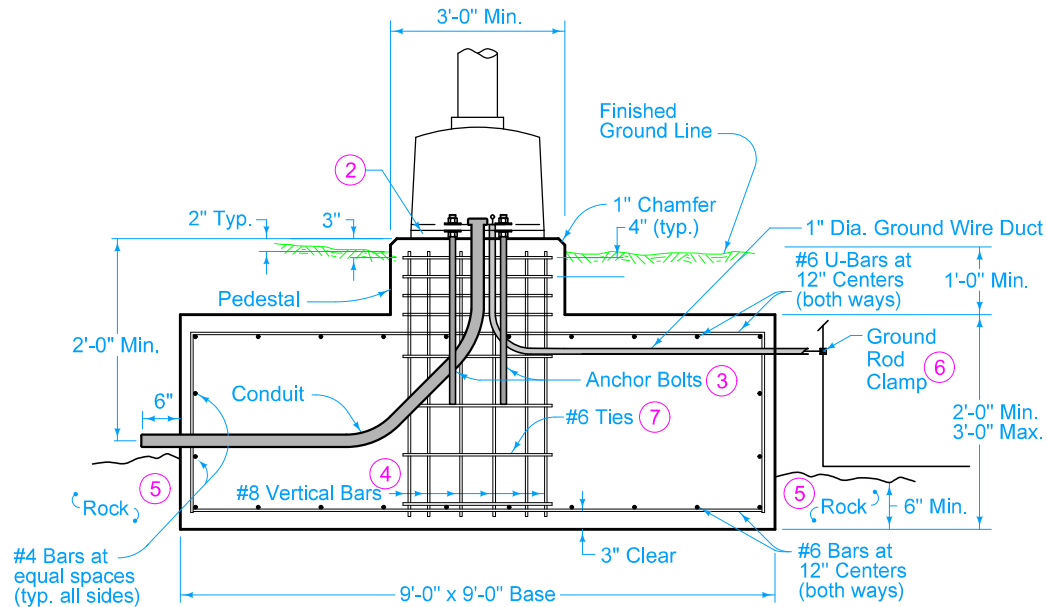

**MAST ARM POLE FOUNDATION IN ROCK  
TYPE B FOUNDATION**

- ② Install rodent guard or non-shrink grout with weep hole.
- ③ Furnish nut, nut and plate, or nut and anchor bolt assembly ring plate on embedded end.
- ④ Place 13 equally spaced #8 vertical bars.
- ⑤ Cast foundation concrete against competent rock. If foundation is formed, place backfill with concrete cast against rock.
- ⑥ When in contact with rock, place ground rods as specified in National Electrical Code, current edition.
- ⑦ #6 bars spaced at 8 inch maximum. Ties may be welded to vertical bars.

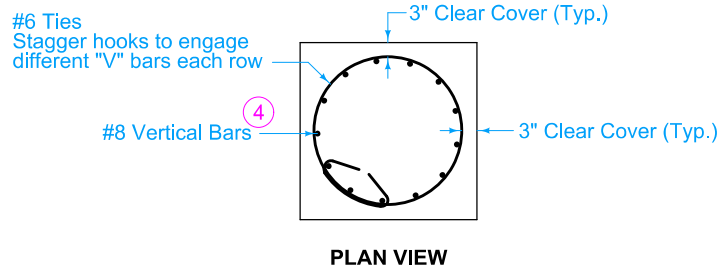

**PLAN VIEW**

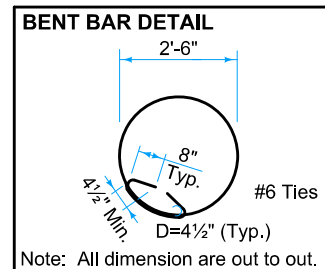

Note: All dimension are out to out.

		REVISION
		4   04-21-20
FIGURE 8010.102	STANDARD ROAD PLAN	<b>TS-102</b>
		SHEET 2 of 4
<small>REVISIONS: Modified conduit details in MAST ARM POLE FOUNDATION drawings on Sheets 1, 2, and 3.</small>		
 SUDAS DIRECTOR		 DESIGN METHODS ENGINEER
<b>TRAFFIC SIGNAL POLE FOUNDATION</b>		

- ① Shape top 11 inches with forms. See Detail 'A'.
- ② Install rodent guard or non-shrink grout with weep hole.
- ③ Furnish nut, nut and plate, or nut and anchor bolt assembly ring plate on embedded end.
- ⑧ When in contact with rock, place ground rods as specified in National Electrical Code, current edition.

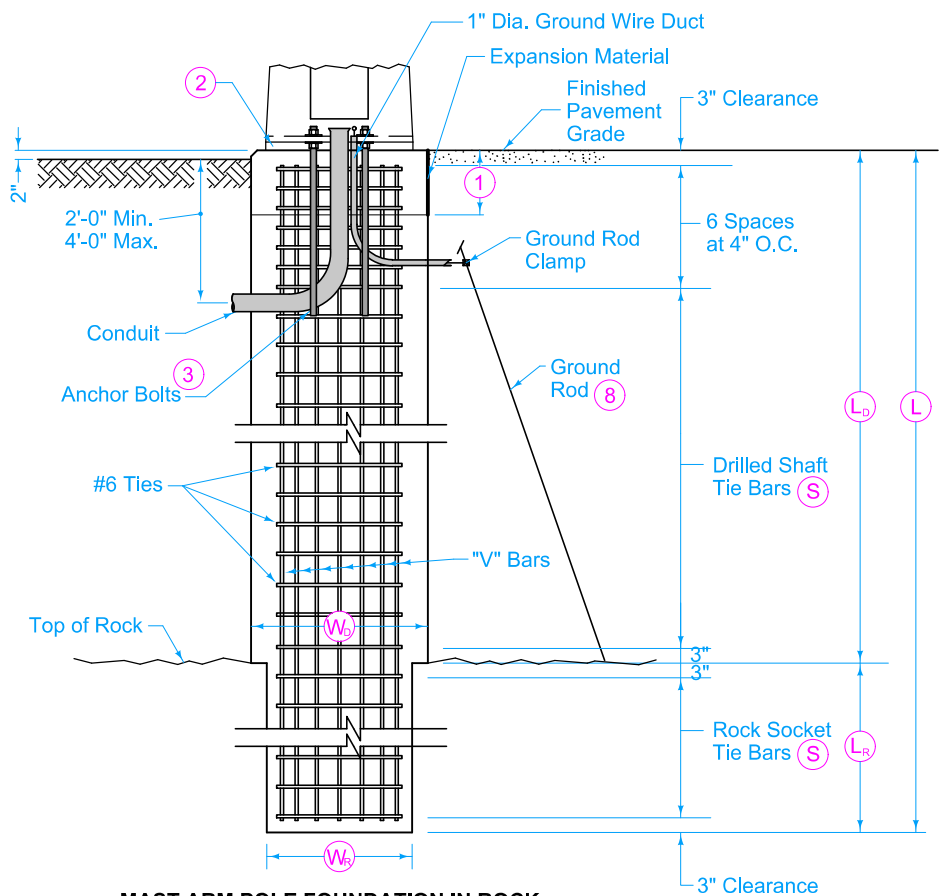

**MAST ARM POLE FOUNDATION IN ROCK  
TYPE C FOUNDATION**

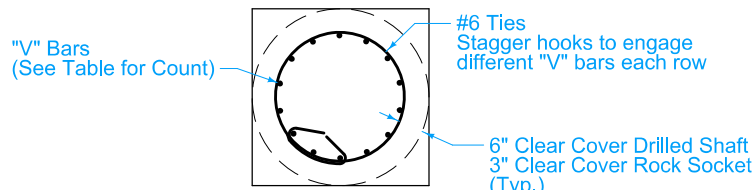

**MAST ARM POLE FOUNDATION**

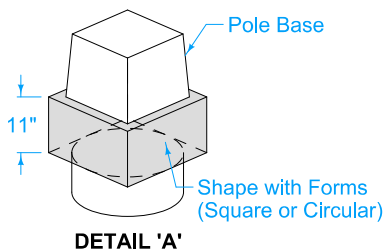

**DETAIL 'A'**

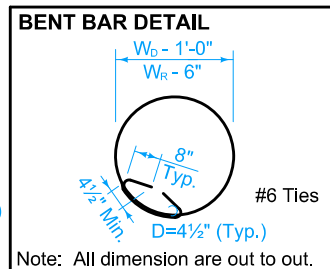

Note: All dimension are out to out.

Max. Mast Arm Length	Foundation						"V" Bars			Tie Bars
	$W_b$	$W_R$	$L$ ***	$L_b$	$L_R$ ****		Count	Size	Length	$S$ Spacing
	Min.	Min.	Max.	Broken Rock*	Competent Rock**					
35'-0"	3'-0"	2'-6"	12'-0"	VARIES $L_b = (L - L_R)$	4'-6"	3'-0"	13	#8	L - 6"	6"
45'-0"	3'-0"	2'-6"	14'-0"		4'-6"	3'-0"	13	#8	L - 6"	6"
55'-0"	3'-0"	2'-6"	16'-0"		4'-6"	3'-0"	13	#8	L - 6"	6"
60'-0"	3'-0"	2'-6"	18'-0"		4'-6"	3'-0"	13	#8	L - 6"	6"
70'-0"	3'-6"	3'-0"	18'-0"		5'-6"	3'-6"	14	#9	L - 6"	5 1/2"
80'-0"	3'-6"	3'-0"	21'-0"		5'-6"	3'-6"	14	#9	L - 6"	5 1/2"
90'-0"	4'-0"	3'-6"	22'-0"		6'-0"	4'-0"	15	#10	L - 6"	5 1/2"
100'-0"	4'-0"	3'-6"	24'-0"		6'-0"	4'-0"	15	#10	L - 6"	5 1/2"

\*Broken rock has an average unconfined compressive strength ( $q_u$ ) of at least 1.0 ksi and rock quality designation of at least 20%.  
 \*\*Competent rock has an average unconfined compressive strength ( $q_u$ ) of at least 2.0 ksi and rock quality designation of at least 90%.  
 \*\*\*Total foundation length L must be sufficient to provide a 3 inch clearance between the bottom of the traffic signal pole anchor bolts and the bottom of the rock socket.  
 \*\*\*\*The Rock Socket Length  $L_R$  can be decreased if the total length of the shaft is L long as shown in the table.  
 Conditions not meeting minimum requirements will require site specific designs or shall use the Type A Foundation Soil parameters.

SUDAS	IOWADOT	REVISION
		4 04-21-20
FIGURE 8010.102	STANDARD ROAD PLAN	<b>TS-102</b>
REVISIONS: Modified conduit details in MAST ARM POLE FOUNDATION drawings on Sheets 1, 2, and 3.		SHEET 3 of 4
<i>Paul D. Wigand</i> SUDAS DIRECTOR		<i>Steve Miller</i> DESIGN METHODS ENGINEER
<b>TRAFFIC SIGNAL POLE FOUNDATION</b>		

- ① Shape top 11 inches with forms. See Detail 'A'.
- ② Install rodent guard or non-shrink grout with weep hole.
- ③ Furnish nut, nut and plate, or nut and anchor bolt assembly ring plate on embedded end.

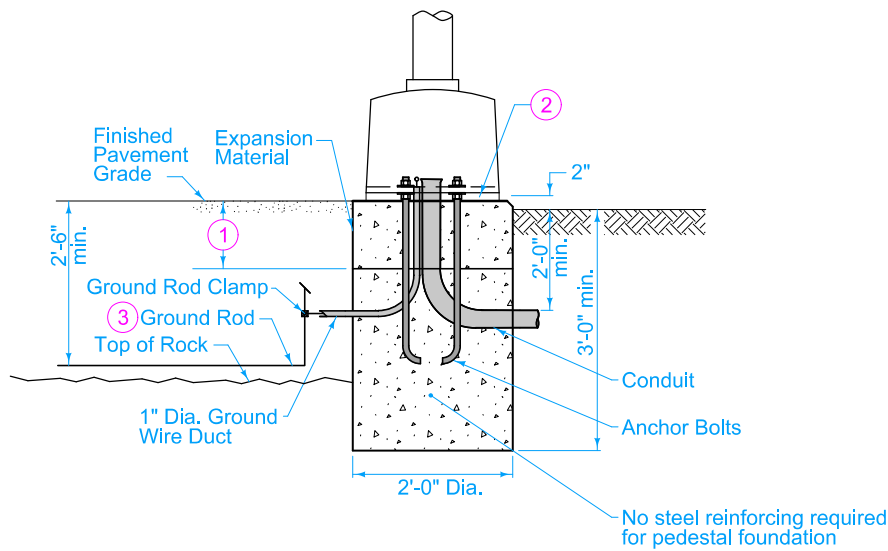

**PEDESTAL POLE FOUNDATION IN SOIL OR ROCK**

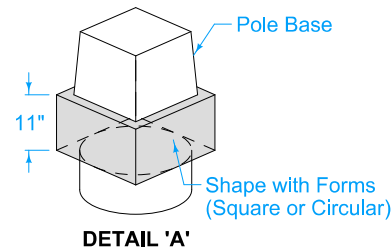

SUDAS	IOWADOT	REVISION
		4   04-21-20
FIGURE 8010.102	STANDARD ROAD PLAN	<b>TS-102</b>
		SHEET 4 of 4
<small>REVISIONS: Modified conduit details in MAST ARM POLE FOUNDATION drawings on Sheets 1, 2, and 3.</small>		
Paul D. Wigand SUDAS DIRECTOR		Steve Miller DESIGN METHODS ENGINEER
<b>TRAFFIC SIGNAL POLE FOUNDATION</b>		