

*****THIS IS A NEW APPENDIX. - PLEASE READ CAREFULLY.*****

NOTES:

ALL STRUCTURAL STEEL, EXCEPT AS NOTED, SHALL CONFORM TO ASTM A709 GRADE 50 (345). SHEAR STUDS ARE TO BE OF AN APPROVED TYPE LISTED IN MATERIALS I.M 453.10, APPENDIX A.

THE BEAM END PLATES SHALL BE GALVANIZED IN ACCORDANCE WITH ASTM A123 GRADE 55. PREPARATION SHALL BE IN ACCORDANCE WITH THE ASTM SPECIFICATION. ALL WELDING SHALL BE COMPLETED PRIOR TO GALVANIZING. BEAM END PLATES ARE TO BE SET IN FORMS WHEN BEAMS ARE CAST AND THE BOTTOM OF BEAMS FORMED OUT AS SHOWN, TO EXCLUDE CONCRETE.

ALL WELDING SHALL BE IN ACCORDANCE WITH AWS D1.1 AS SPECIFIED BY THE STANDARD SPECIFICATIONS AND CURRENT SUPPLEMENTAL SPECIFICATIONS.

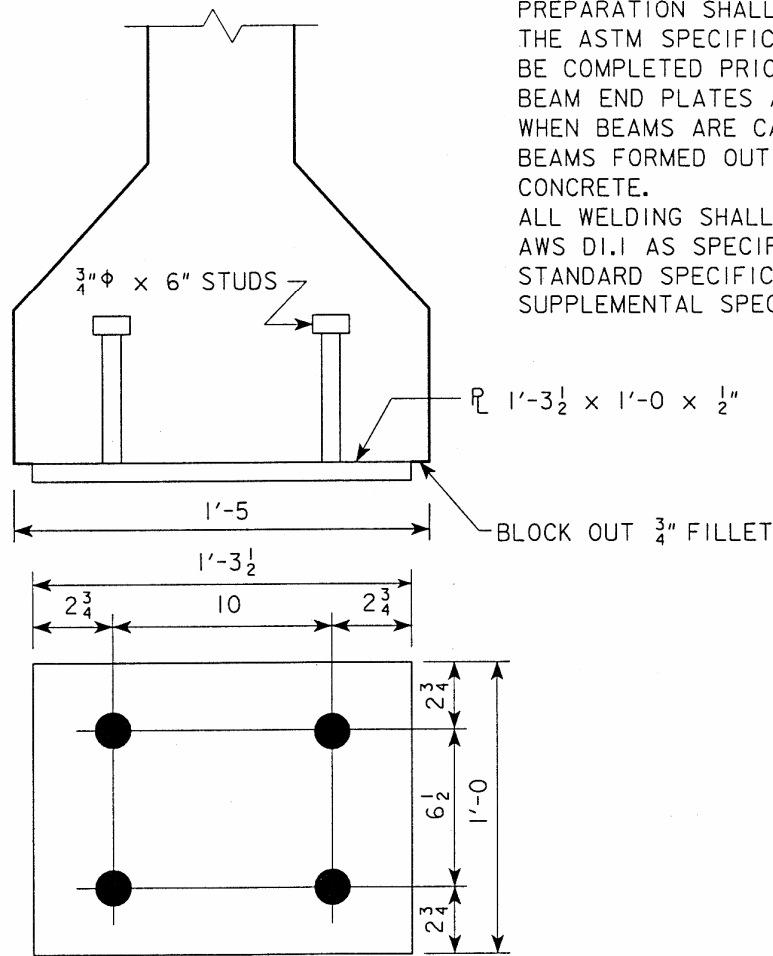

A and B BEAMS

Figure 1. - Optional Beam Seat Protection Plate

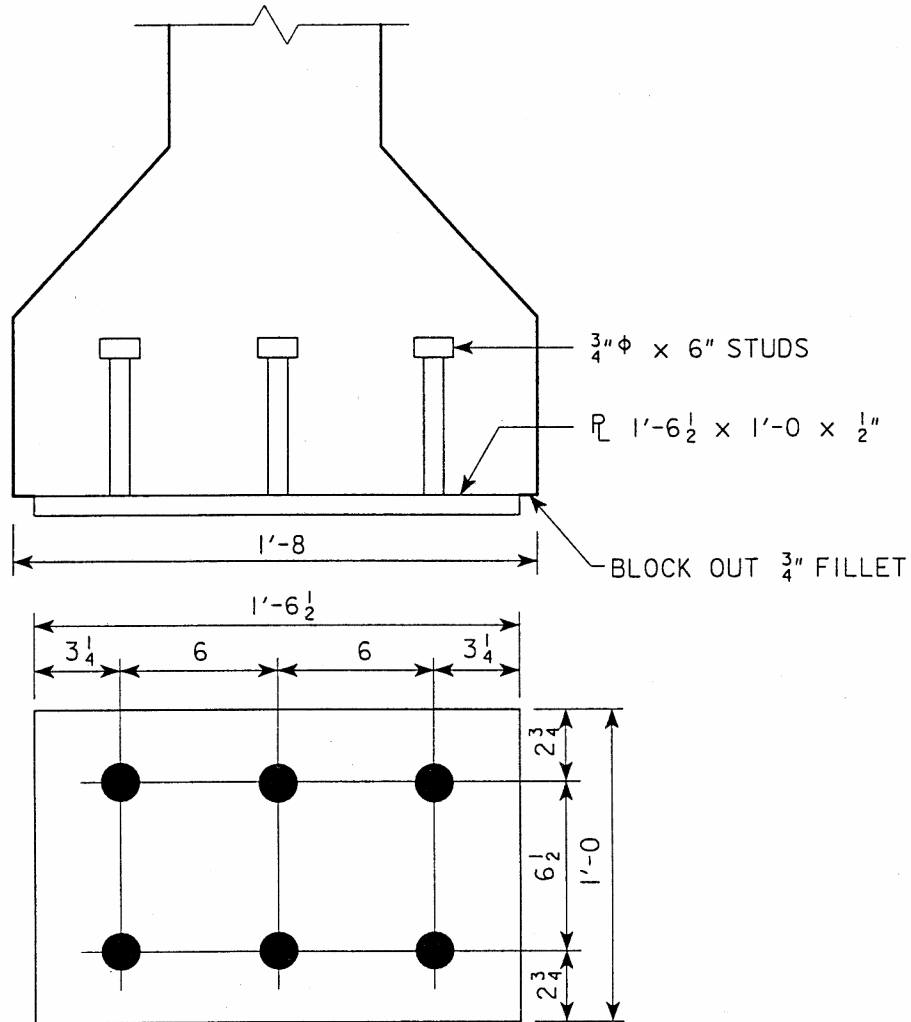

C BEAMS

Figure 2. - Optional Beam Seat Protection Plate

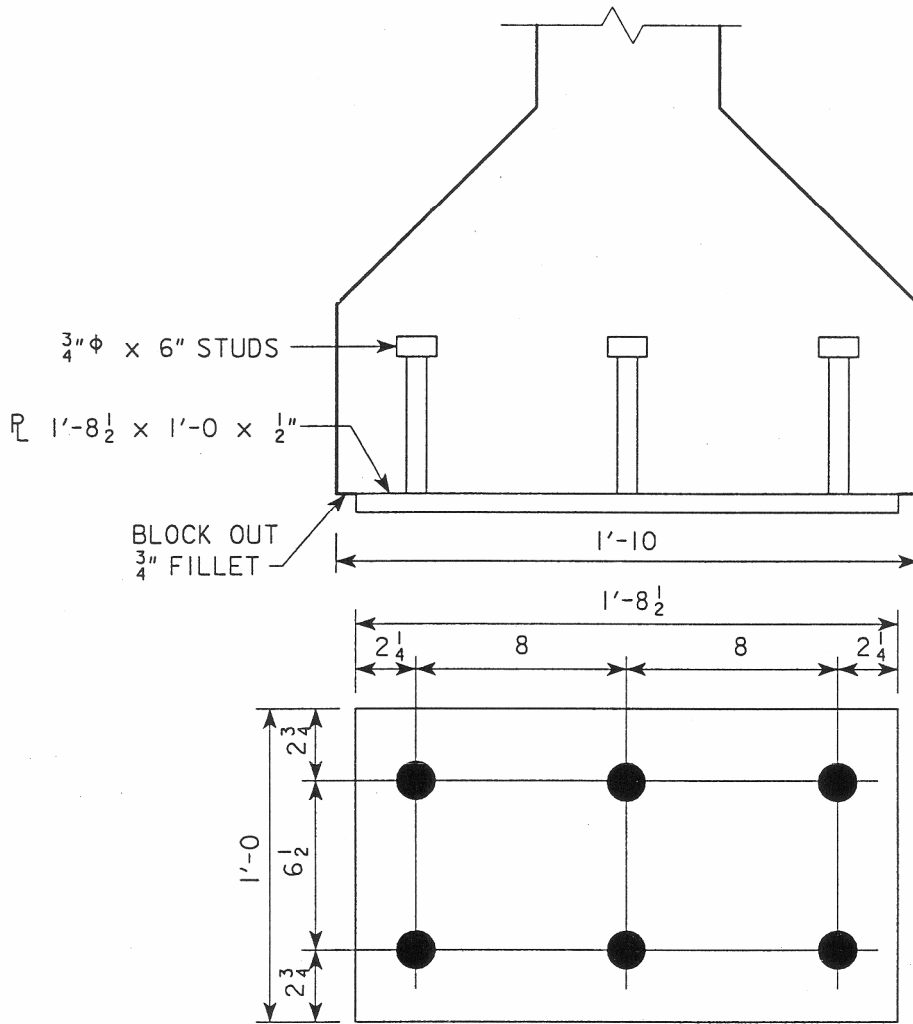

D BEAMS

Figure 3. - Optional Beam Seat Protection Plate

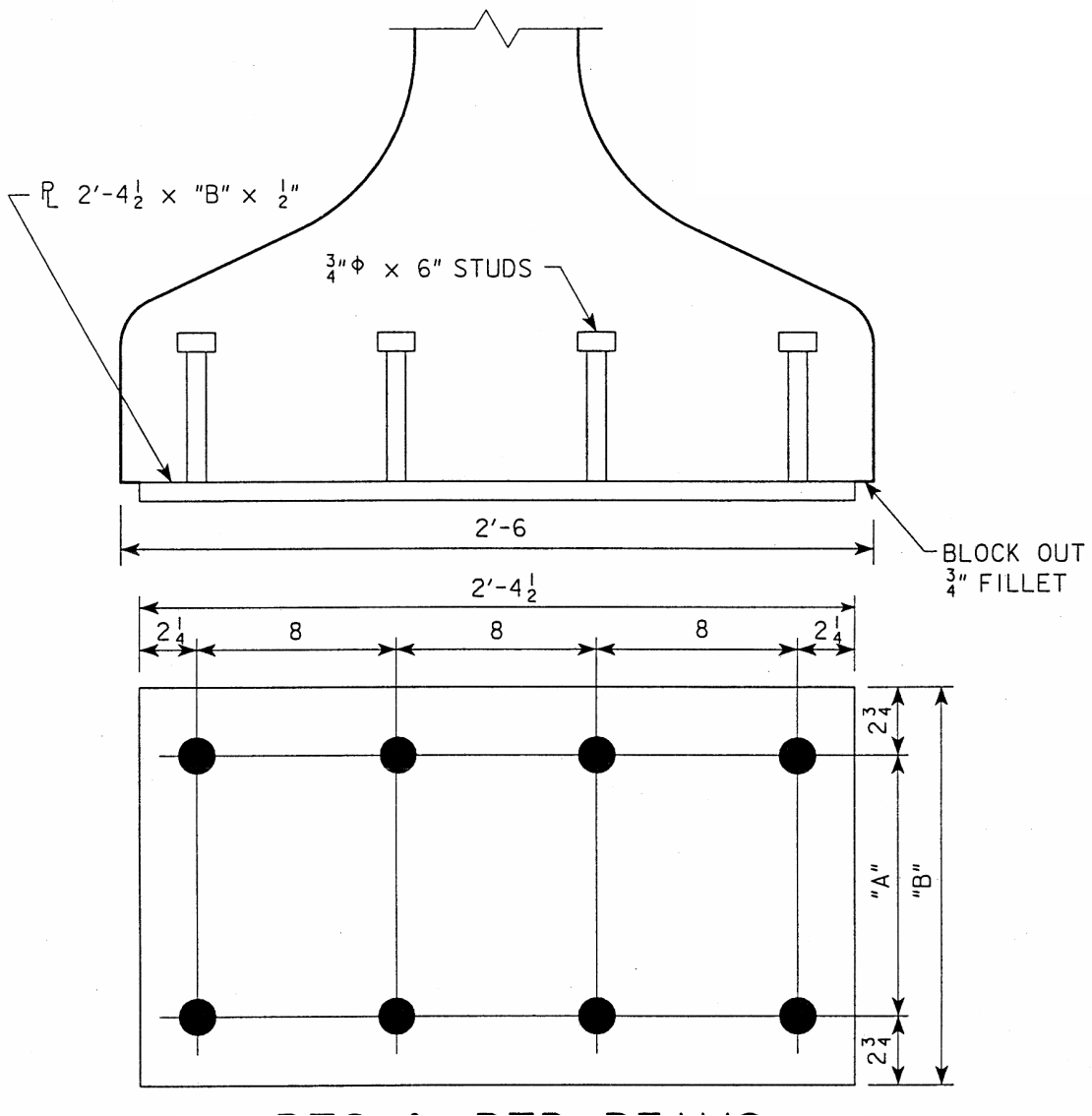

BTB. BTC. BTD. and BTE BEAMS

Figure 4. - Optional Beam Seat Protection Plate

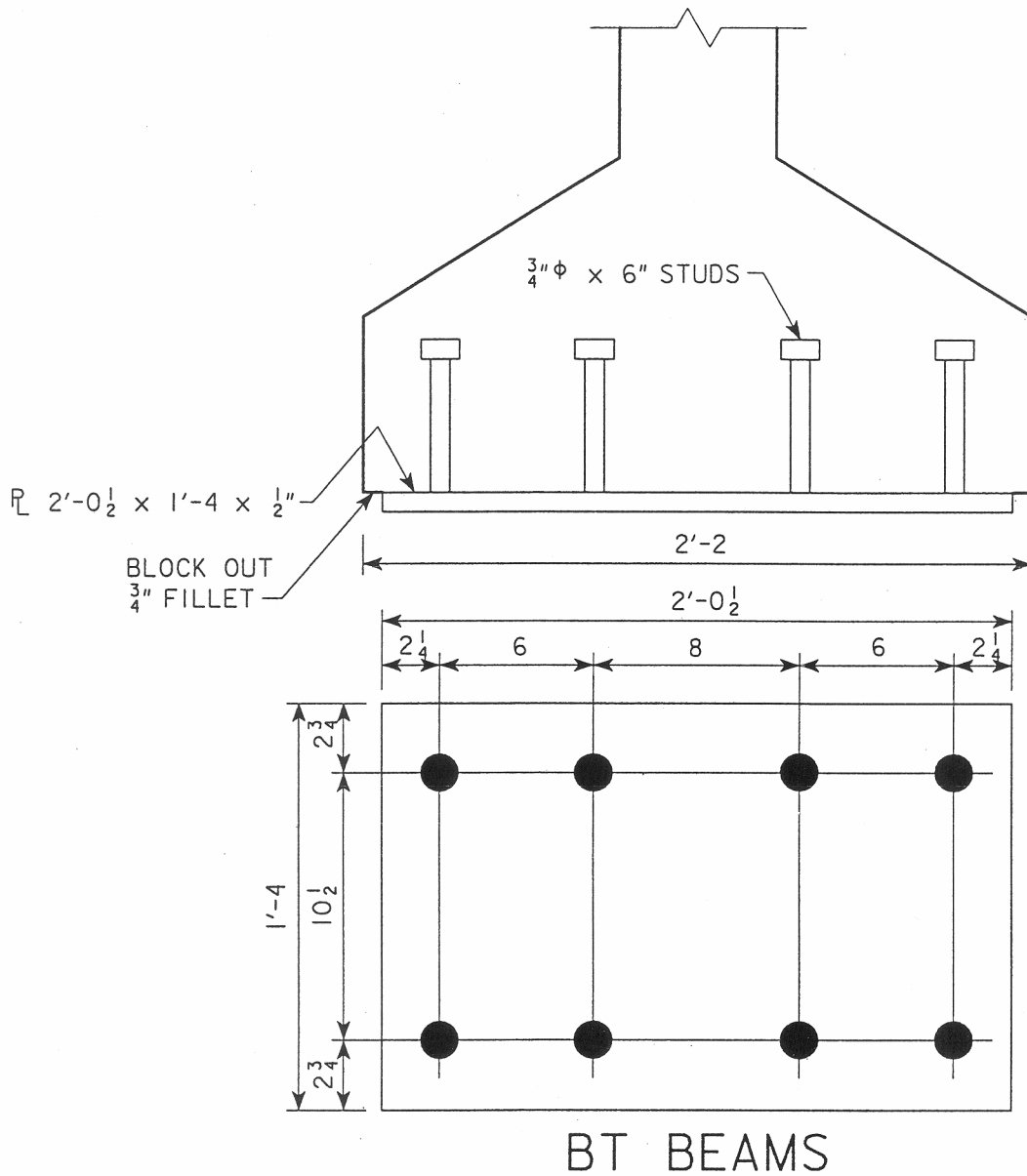

Figure 5. - Optional Beam Seat Protection Plate