

DETAILS OF HYDRANT AND AIR GAP ATTACHMENT

TYPICAL PLAN OF DISPOSAL STATION FOR TRAVEL TRAILER

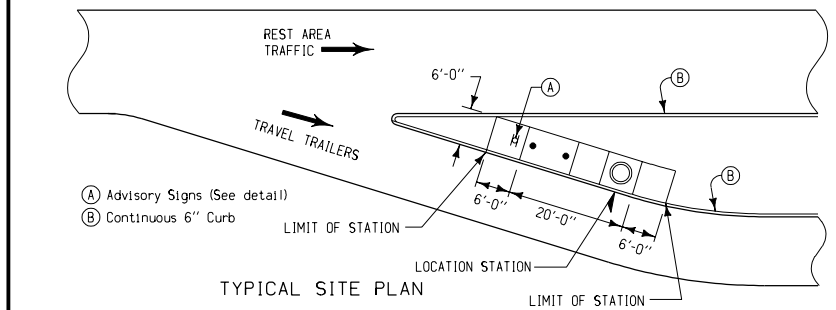
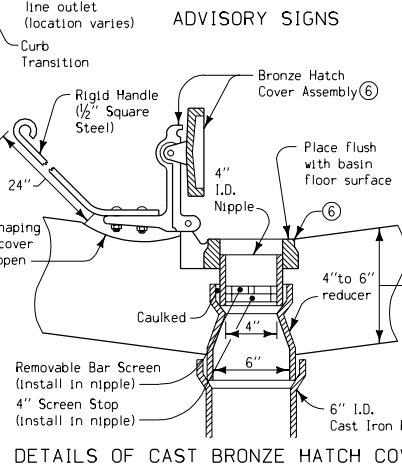

GENERAL NOTES:

Details shown are the general requirements for construction of a facility for disposing of liquid waste carried by travel trailers and motor homes. Alternate designs for the various details may be submitted for approval.

All construction shall be in accordance with current Standard and Supplemental Specifications and project plans. All accessory hardware shall be galvanized or painted as directed by the Engineer. Any work or materials required which are not specifically covered shall be as directed or approved by the Engineer.

Hydrants shall be combination freezable and standard operating units or freezable and self-closing (as designated on the plans), of a design and construction approved by the Engineer and equipped with approved model accessory attachment as indicated. Riser pipe for hydrants shall be one inch I.D. galvanized water pipe.

After the water line (to the last hydrant on the line) has been placed and inspected, the line shall be tested and proven free of leaks under 100 lbs. per square inch air pressure with soap and water or other proven means. The line shall be required to maintain such pressure 24 hours. Upon successful completion of inspection and testing, excavated material shall be returned to the trench and tamped. Water lines for rim flush basin shall be either type "K" copper or galvanized pipe with appropriate fittings as necessary and installed as shown and as directed by the Engineer.

Advisory signs and a single 4 inch x 4 inch post shall be furnished by the Iowa Department of Transportation. Signs are to be mounted back-to-back on post. Exact location is to be determined by the Engineer at the time of installation by the Contractor.

Details shown for hatch cover are typical. It shall be self-closing, cast bronze type of a design and construction approved by the Engineer. Handle shall be shaped to ensure self-closing feature.

Price bid for each "Sanitary Disposal Station" shall be considered full compensation for furnishing all materials and performing all work necessary to construct the facility as directed by the Engineer.

- ① Place hydrant drain a minimum of 2 inches above porous backfill to ensure proper operation.
- ② Position 8 inch I.D. Standpipe so that no damage will result to the normal operation of water lines and drain tile located in the immediate vicinity.
- ③ Block standpipe to prevent concrete from entering pipe during construction of slab.
- ④ Copper tube connection from hydrant.
- ⑤ Inside of standpipe shall be void of material.
- ⑥ 4" cast iron threaded base with bronze cover and handle and provisions for locking - model 41 from VAREC, Inc. Cypress, CA.
- ⑦ Below frost line at depth as directed by the Engineer.

Iowa Department of Transportation Project Development Division	
STANDARD ROAD PLAN	RA-59
REVISION: Replaces Standard Road Plan RA-24.	REVISION NO. New
APPROVED BY: <i>John C. Christy</i> DESIGN METHODS ENGINEER	11-05-99 REVISION DATE
SANITARY DISPOSAL STATION TRAVEL TRAILER	