

ELEVATION

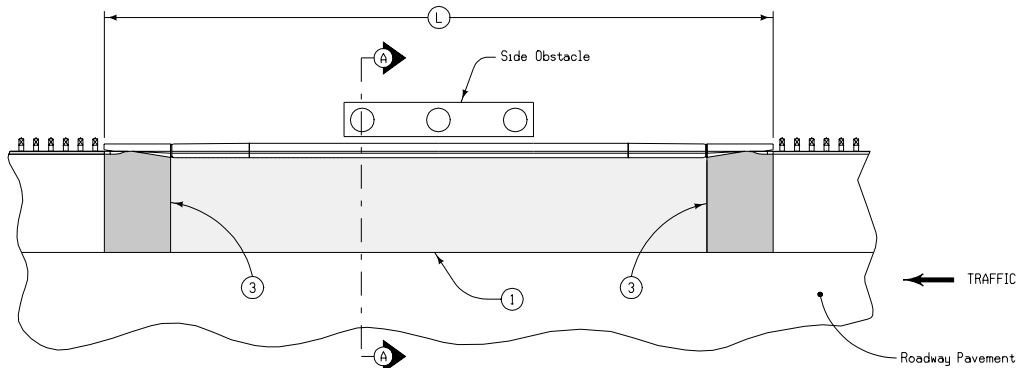

PLAN VIEW

- ① "L-2" or "KT-2" joint. When roadway pavement is existing, use "BT-3" joint. Refer to RH-51.
- ② Refer to RE-65B.
- ③ "C" Joint; match existing roadway joints when possible. Refer to RH-50.
- ④ Refer to RH-41B or project typicals.
- ⑤ Refer to RE-44J.

Contract Items:
 Concrete Barrier
 Installation of Guardrail
 PCC Paved Shoulder
 Reinforced Paved Shoulder

Tabulations:
 108-18B, 112-9

- LEGEND
- PCC Paved Shoulder ④
 - Reinforced PCC Paved Shoulder ⑤

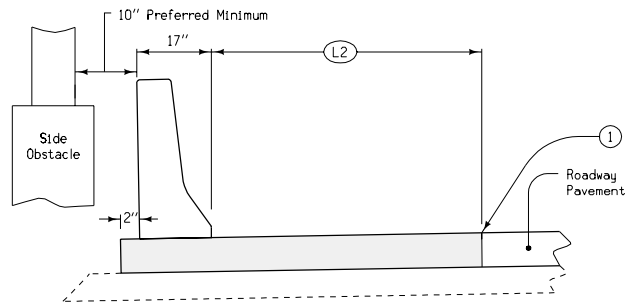

SECTION A-A

Iowa Department of Transportation	REVISION
	1 04-17-07
STANDARD ROAD PLAN	RE-74
REVISIONS: Corrected "L" distance and removed "Location Station".	
SHEET 1 of 1	
<small>APPROVED BY DESIGN METHODS ENGINEER</small>	
SIDE OBSTACLE PROTECTION WITH CONCRETE BARRIER AND GUARDRAIL	