

CASE 'A'
 (Full Shoulder Width Bridge)

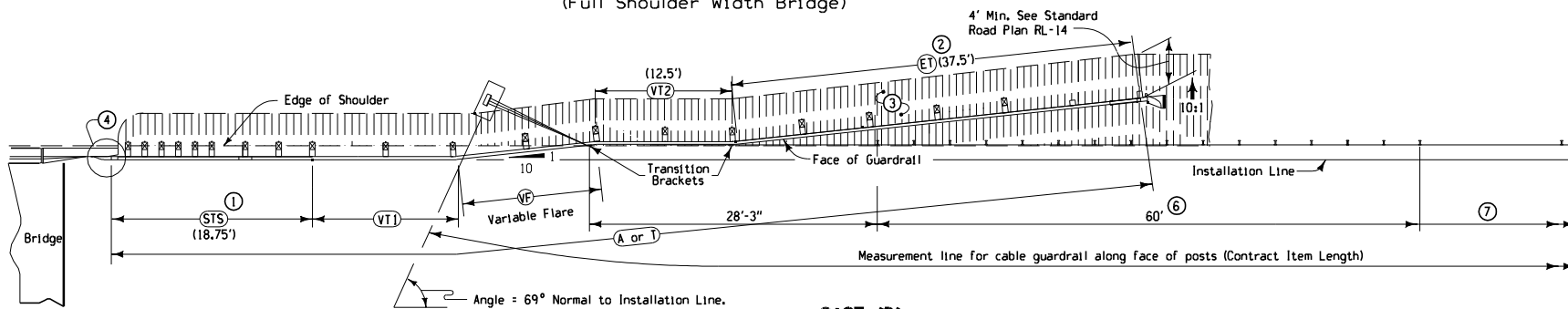

CASE 'B'
 (Less Than Full Shoulder Width Bridge)

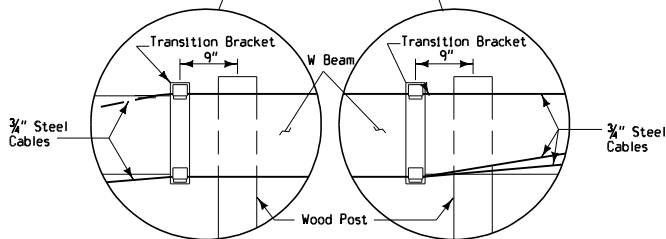
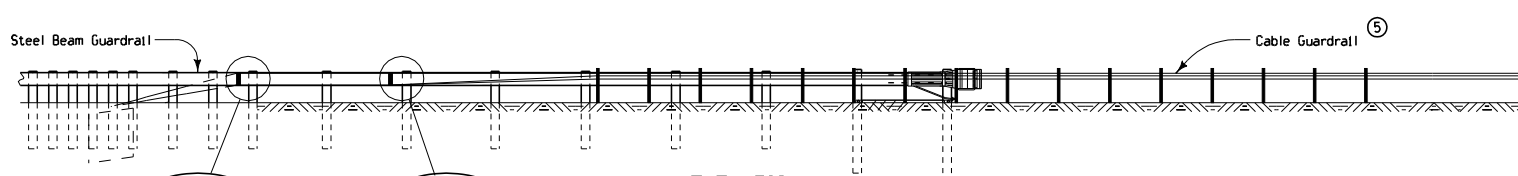

- ① Refer to Standard Road Plan RE-68.
- ② Refer to Standard Road Plan RE-76.
- ③ For grading requirements, see Standard Road Plan RL-14.
- ④ For connections to bridge end post see Standard Road Plan RE-69A, RE-69B, or RE-69C.
- ⑤ Refer to Standard Road Plan RE-29C.
- ⑥ Cable Guardrail Post at 4' spacing.
- ⑦ Cable Guardrail Post at 16' spacing.

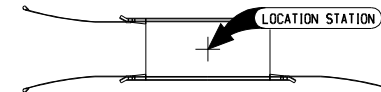

 Iowa Department of Transportation	REVISION
	1 10-21-08
STANDARD ROAD PLAN	RE-84
REVISIONS: Deleted Note 8.	SHEET 1 of 2
<i>Deanna Marlett</i> APPROVED BY DESIGN METHODS ENGINEER	
CABLE/W-BEAM GUARDRAIL CROSSOVER	

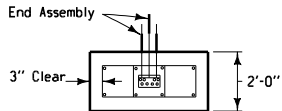
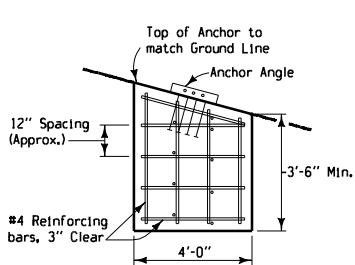

TYPE 'A' END ANCHORAGE DETAILS

Anchor shall be cast in place with ϵ normal to line of guardrail. Excavation for anchor shall be to the neat lines indicated. Forms will be allowed only for the ends (the 2' dimension) of the anchor.

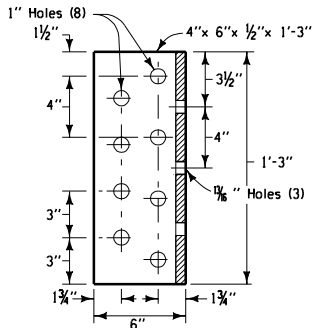
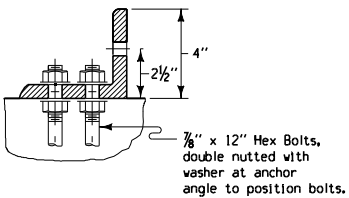

ANCHOR ANGLE

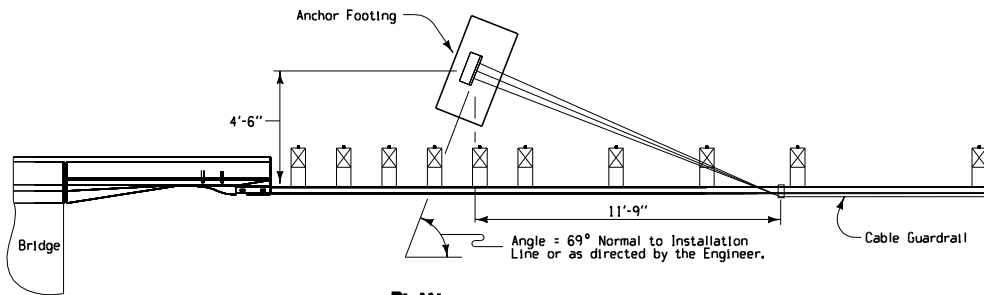

PLAN

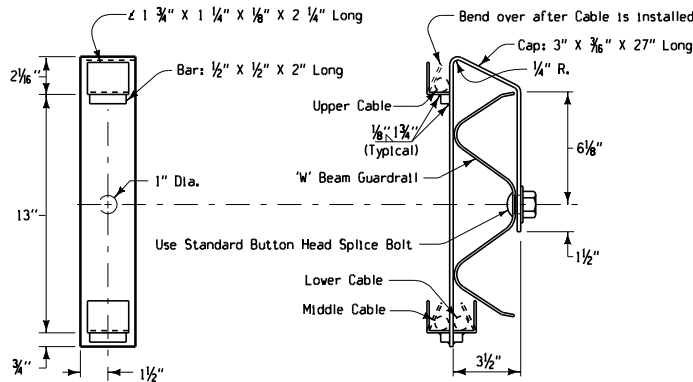

TRANSITION BRACKET

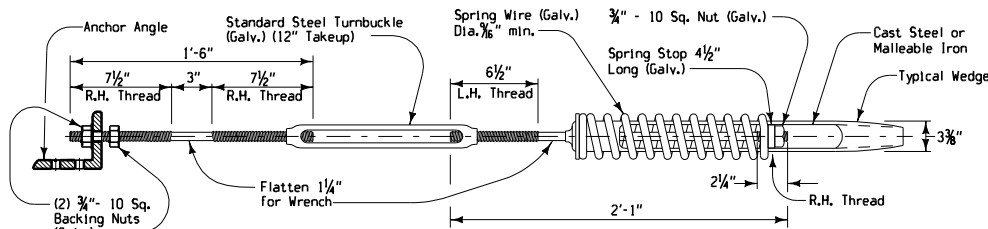

SPRING CABLE END ASSEMBLY WITH TURNBUCKLE (Compensating Device)

CABLE TENSION ADJUSTMENTS FOR TEMPERATURE VARIATIONS														
Temperature Range Degrees F	120 to 110	109 to 100	99 to 90	89 to 80	79 to 70	69 to 60	59 to 50	49 to 40	39 to 30	29 to 20	19 to 10	9 to 0	-1 to -10	-11 to -20
Spring Compression Inches *	1	1 1/4	1 1/2	1 3/4	2	2 1/4	2 1/2	2 3/4	3	3 1/4	3 1/2	3 3/4	4	4 1/4

* From the unloaded position in each spring

Steel used in the fabrication of the brackets shall conform to ASTM A36. The brackets shall be galvanized after fabrication according to ASTM A123.

Gas Metal-Arc and Flux-Cored Arc Welding may be used for welding incidental items as indicated on this sheet, provided that the fabricator furnishes certification for the filler metal and gas, uses filler metal on the approved list furnished by the Office of Materials, uses prequalified welding procedures, and uses qualified welders approved by the Iowa DOT.

List of materials for the RE-29A Type 'A' End Anchorage:

- (1) Anchor Angle and Hardware
- 1.19 cubic yards concrete
- 59 lbs. of reinforcing steel (approx.)
- (3) Cable End Assemblies
- (2) Transition Brackets

<p>Iowa Department of Transportation</p>	REVISION 1 10-21-08
	<p>RE-84</p> <p>SHEET 2 of 2</p>
<p>STANDARD ROAD PLAN</p> <p>REVISIONS: Deleted Note 8</p> <p style="text-align: right;"><i>Deanna Mielich</i> APPROVED BY DESIGN METHODS ENGINEER</p>	
<p>CABLE/W-BEAM GUARDRAIL CROSSOVER</p>	