

TYPICAL SIGN INSTALLATION

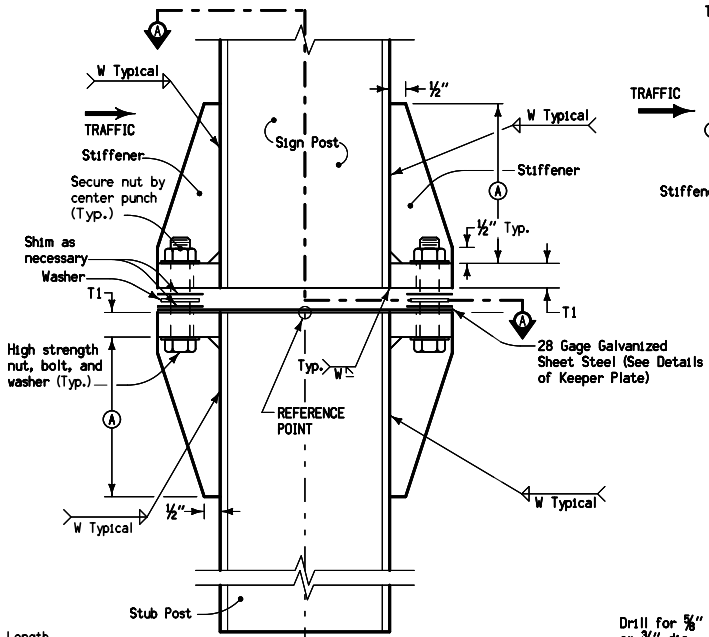

**Side View
BREAKAWAY
BASE DETAILS**

(W) Welds shall be continuous fillet welds and of a depth equal to the thickness of the flange for the post unless otherwise specified.

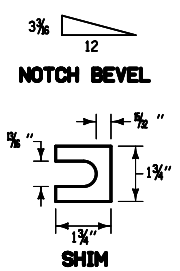

NOTCH BEVEL

SHIM

POST DATA	
Post Size	Stub Length
W 6 x 9	2'-6"
W 6 x 12	
W 6 x 15	
W 8 x 18	
W 8 x 21	3'-0"
W 10 x 22	
W 10 x 26	
W 12 x 26	

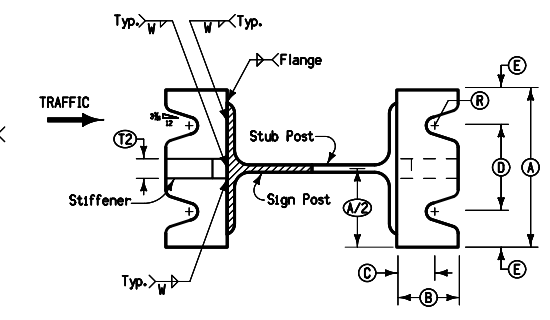

**Section A-A (Plan)
DETAILS OF BASE**

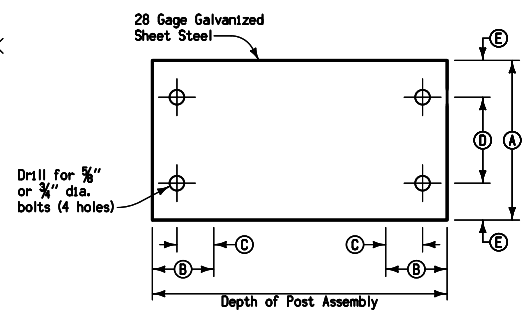

DETAILS OF KEEPER PLATE

Signpost shall be plumbed by installing shims. The Contractor shall furnish two shims each of 0.012" and 0.032" thickness (total of 4 per post). Shims shall be brass stock or strip conforming to ASTM B 36.

Details are shown for signs to be installed to the right of roadway traffic. All installations will be this, unless specified otherwise. For a left side installation, the notches in the breakaway base plate would be beveled in opposite direction as that shown.

Base plates (2 each), shall be welded to sides of signpost and stub post flanges.

① Not for single post installations.

Contract Item:
Steel Breakaway Sign Post

BREAKAWAY BASE DATA										
Post Size	Bolt Size & Torque	A	B	C	D	E	T1	T2	W	R
W 6 x 9	5/8" dia. x 2 3/4" Torque = 37.50 ft. lbs.	5"	2"	1 1/4"	2 3/4"	1 1/8"	3/4"	1/2"	1/4"	1/2"
W 6 x 12										
W 6 x 15										
W 8 x 18										
W 8 x 21	3/4" dia. x 3 1/2" Torque = 62.50 ft. lbs.	6	2 1/4"	1 3/8"	3 1/2"	1 1/4"	1"	3/4"	5/8"	3/2"
W 10 x 22										
W 10 x 26										
W 12 x 26										

Iowa Department of Transportation

NEW 04-21-09

SI-113

SHEET 1 of 3

REVISIONS: New.

Deanna Mailfield
APPROVED BY DESIGN METHODS ENGINEER

**SUPPORT STRUCTURES -
STEEL BREAKAWAY POSTS**

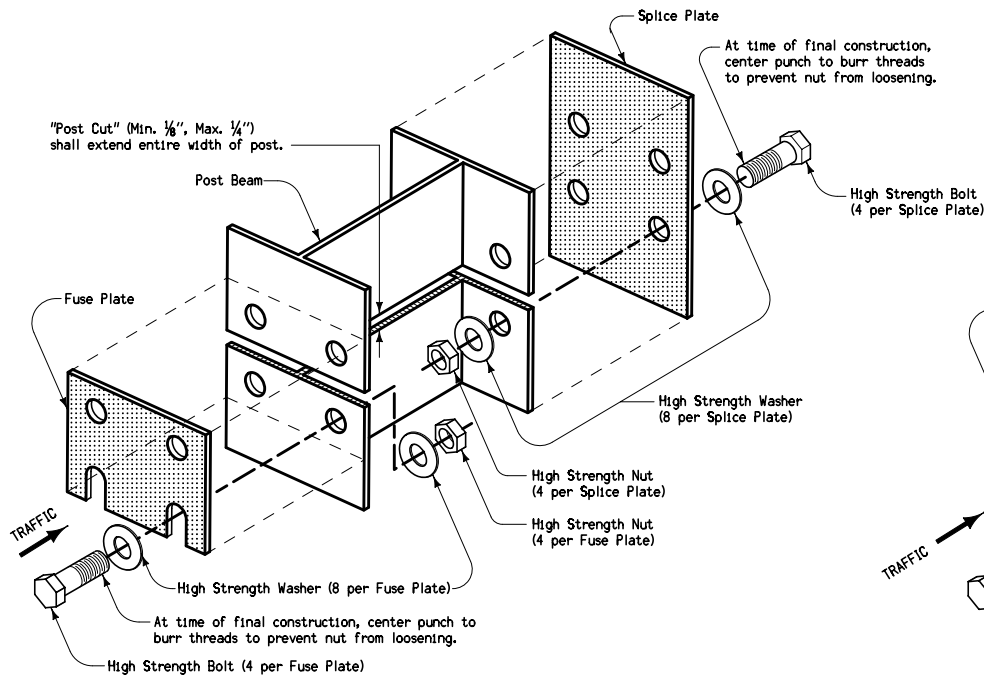

**Hinge Alternate 1
(With Splice Plate)**

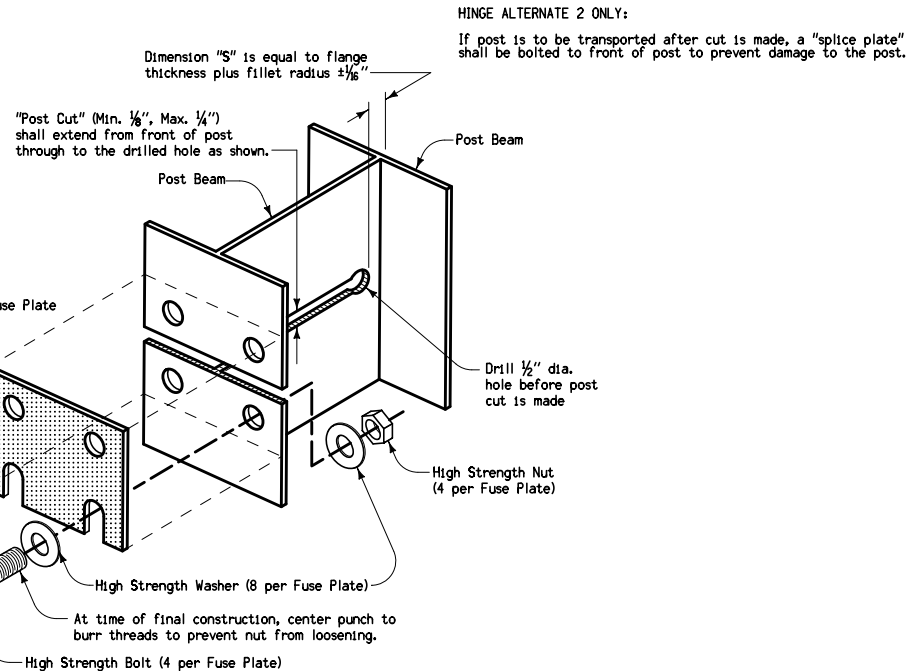

**Hinge Alternate 2
(One-Piece Post)**

DETAILS OF FUSE PLATE ASSEMBLY

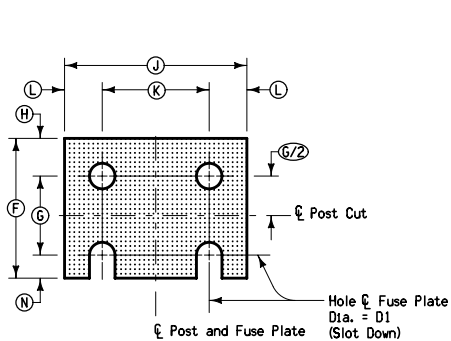

**FUSE PLATE
(Thickness T3)**

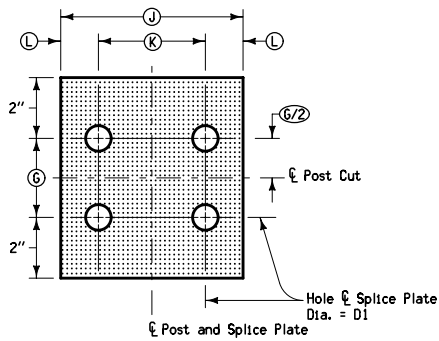

**SPLICE PLATE
(Thickness T4)**

Bolt Size	Torque
1/2"	100 Ft. Lbs.
5/8"	180 Ft. Lbs.
3/4"	320 Ft. Lbs.
7/8"	470 Ft. Lbs.

FUSE AND SPLICE PLATE DATA											
Post Size	Bolt Dia.	F	G	H	J	K	L	N	D1	T3	T4
W6x9	1/2"	3 5/8"	2"	1 1/8"	4"	2 1/4"	7/8"	1/2"	5/8"	1/4"	1/4"
W6x12	5/8"	3 3/4"	2"	1 1/8"	4"	2 1/4"	7/8"	5/8"	1/2"	3/8"	1/4"
W6x15	3/4"	4 1/2"	2 1/2"	1 1/4"	6"	3 1/2"	1 1/4"	3/4"	5/8"	1/2"	1/4"
W8x18	3/4"	4 1/2"	2 1/2"	1 1/4"	5 1/4"	2 3/4"	1 1/4"	3/4"	5/8"	1/2"	3/8"
W8x21	7/8"	4 7/8"	2 1/2"	1 1/2"	5 1/4"	2 3/4"	1 1/4"	7/8"	5/8"	5/8"	3/8"
W10x22	7/8"	5 3/8"	3"	1 1/2"	5 3/4"	2 3/4"	1 1/2"	7/8"	5/8"	5/8"	3/8"
W10x26	7/8"	5 3/8"	3"	1 1/2"	5 3/4"	2 3/4"	1 1/2"	7/8"	5/8"	5/8"	3/8"
W12x26	7/8"	5 3/8"	3"	1 1/2"	6 1/2"	3 1/2"	1 1/2"	7/8"	5/8"	5/8"	3/8"

<p>Iowa Department of Transportation</p>	REVISION
	NEW 04-21-09
STANDARD ROAD PLAN	SI-113
REVISIONS: New.	SHEET 2 of 3
<p>APPROVED BY DESIGN METHODS ENGINEER</p>	
<p>SUPPORT STRUCTURES - STEEL BREAKAWAY POSTS</p>	

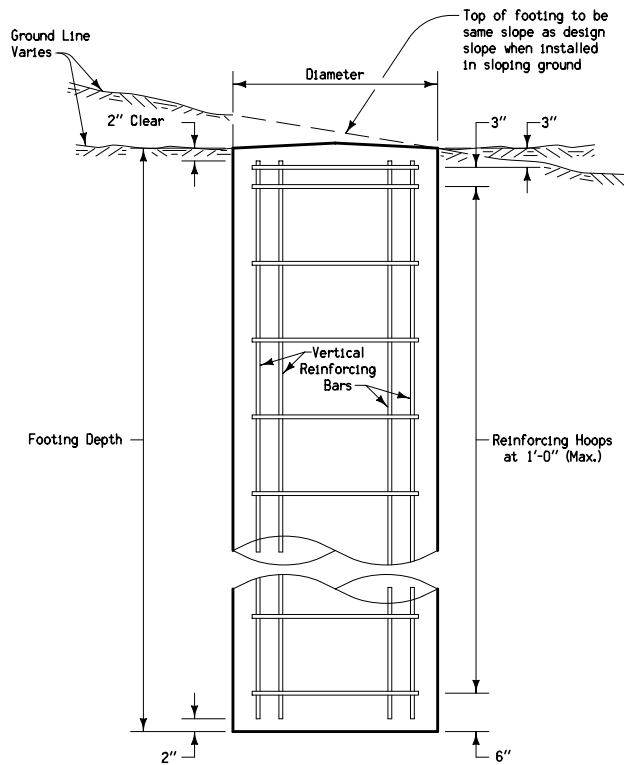

**TYPICAL INSTALLATION
NORMAL FOOTING IN EARTH**

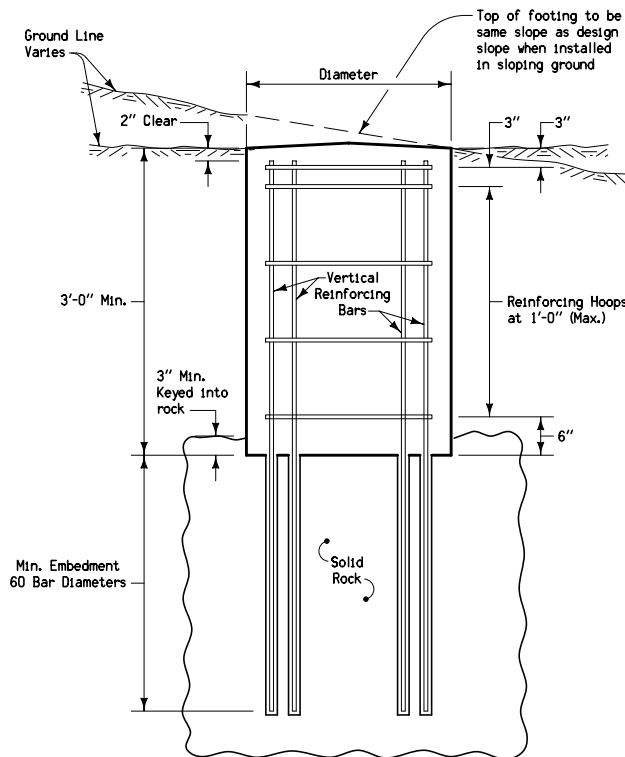

**ALTERNATE DESIGN
FOOTING IN SOLID ROCK**

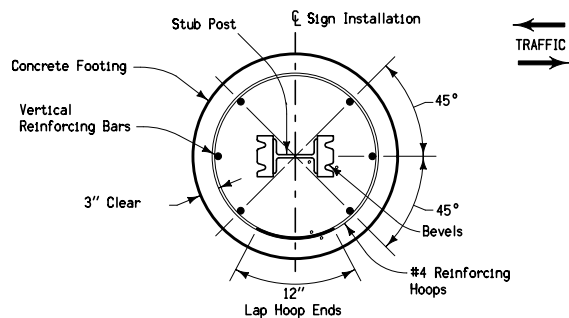

PLAN VIEW

(REINFORCING PLACEMENT AND SIGN ORIENTATION)
Note: Refer to RD-21A for details of sign post and stub.

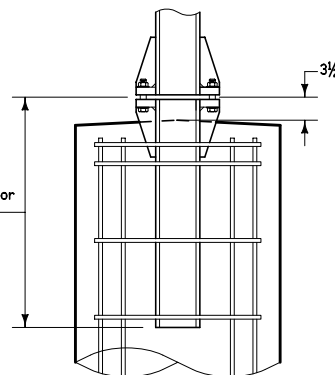

TYPICAL BREAKAWAY POST INSTALLATION

The footing shall be constructed as shown for normal footing in earth. Where solid rock is encountered, the alternate design for footing in solid rock may be used with the approval of the Engineer.

All excavation for the footing shall be disposed of in the area adjacent to the footing and shaped to normal ground contour, unless directed otherwise by the Engineer.

The stub post shall be held in proper position by an approved device which will ensure that it remains in proper position upon completion of concrete placement.

The contract price for size of footing required shall be full compensation for construction of footing as detailed hereon, including all necessary excavation regardless of character.

NOTE:

Vertical bars in solid rock shall be set as follows:

1. Drill holes twice bar diameter and fill with water.
2. When hole is fully saturated; blow water out and fill two-thirds depth with sand cement mortar.
3. Insert bar and consolidate mortar.
4. Fill hole to top with mortar.

FOOTING REINFORCING DATA					
Post Size	Stub Length	Footing		Vertical Rein. Bar	
		Diameter	Depth	Size	Length ①
W6x9	2'-6"	2'-0"	6'-0"	No. 6	5'-8"
W6x12	2'-6"	2'-0"	6'-0"	No. 6	5'-8"
W6x15	2'-6"	2'-0"	6'-6"	No. 6	6'-2"
W8x18	2'-6"	2'-0"	7'-0"	No. 6	6'-8"
W8x21	3'-0"	2'-8"	7'-6"	No. 8	7'-2"
W10x22	3'-0"	2'-8"	8'-0"	No. 8	7'-8"
W10x26	3'-0"	2'-8"	8'-6"	No. 8	8'-2"
W12x26	3'-0"	2'-8"	9'-0"	No. 8	8'-8"

① Lengths are for normal footings. Required length may vary where alternate rock design is used.

	REVISION
	NEW 04-21-09
STANDARD ROAD PLAN	SI-113
REVISIONS: New.	SHEET 3 of 3
APPROVED BY DESIGN METHODS ENGINEER	
SUPPORT STRUCTURES - STEEL BREAKAWAY POSTS	