

ASSEMBLY DETAIL

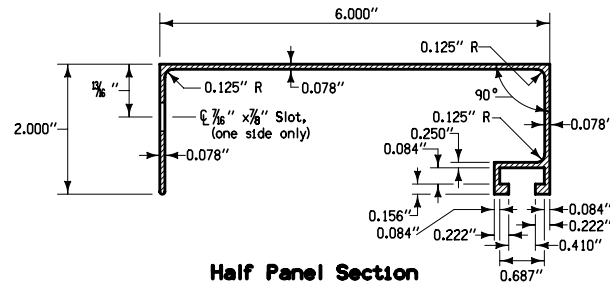

Half Panel Section

Panel bolt slotted holes spaced at 12 inch centers shall be located along the full length of each panel, such that the outermost slots are of equal distances (not to exceed 6 inches) from the ends of the panel.

Signs shall be made up of full panels unless a half panel is required, in which case it shall be placed at the top edge of the sign.

Refer to appropriate other Standard Road Plans for details of Sign Posts, Footings, etc.. Refer to detail project plans and summary sheet for exact data for individual sign fabrication requirements.

① 2 Washers per panel bolt, one each side of sign.

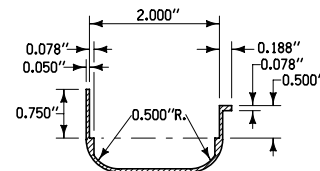

EDGE MOLDING

Actual Length of Panels = Design Length + 1.5"
3/4"

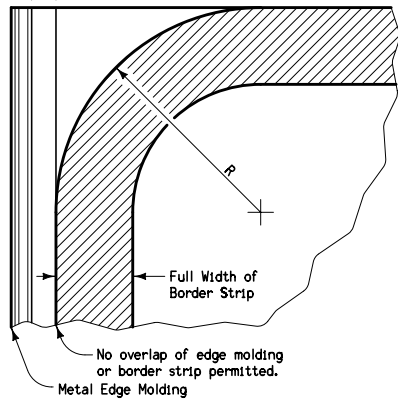

EDGE MOLDING BORDER STRIP DETAIL

Edge molding shall be installed full length of each vertical side of each sign. Attach in accordance with current specifications.

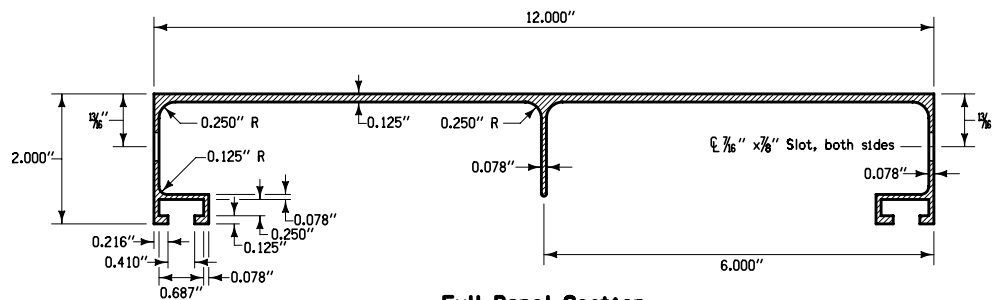

Full Panel Section
STANDARD STRUCTURAL SIGN PANELS

	REVISION
	NEW 04-21-09
STANDARD ROAD PLAN	SI-123
REVISIONS: New.	SHEET 1 of 1
<i>Deanna Milfield</i> APPROVED BY DESIGN METHODS ENGINEER	
FABRICATION - TYPE 'B' SIGNS	