

INSERT

- ① Modify dimensions as required to accommodate other curb heights when specified.
- ② Insert shaping may be modified for insert widths less than 36 inches. For an 18 inch insert, reduce dimensions indicated by 1/2 inch.
- ③ 12 inch minimum wall height above all pipes.

FIGURE 6010.508 SHEET 1 OF 2

SUDAS	Iowa Department of Transportation	REVISION
		NEW 04-21-09
FIGURE 6010.508	STANDARD ROAD PLAN	SW-508
		SHEET 1 of 2
REVISIONS: New. Replaces SUDAS Type "M-F" (Modified) Intake. Will replace RA-40.		
SUDAS DIRECTOR		DESIGN METHODS ENGINEER
SINGLE OPEN-THROAT INTAKE, LARGE BOX		

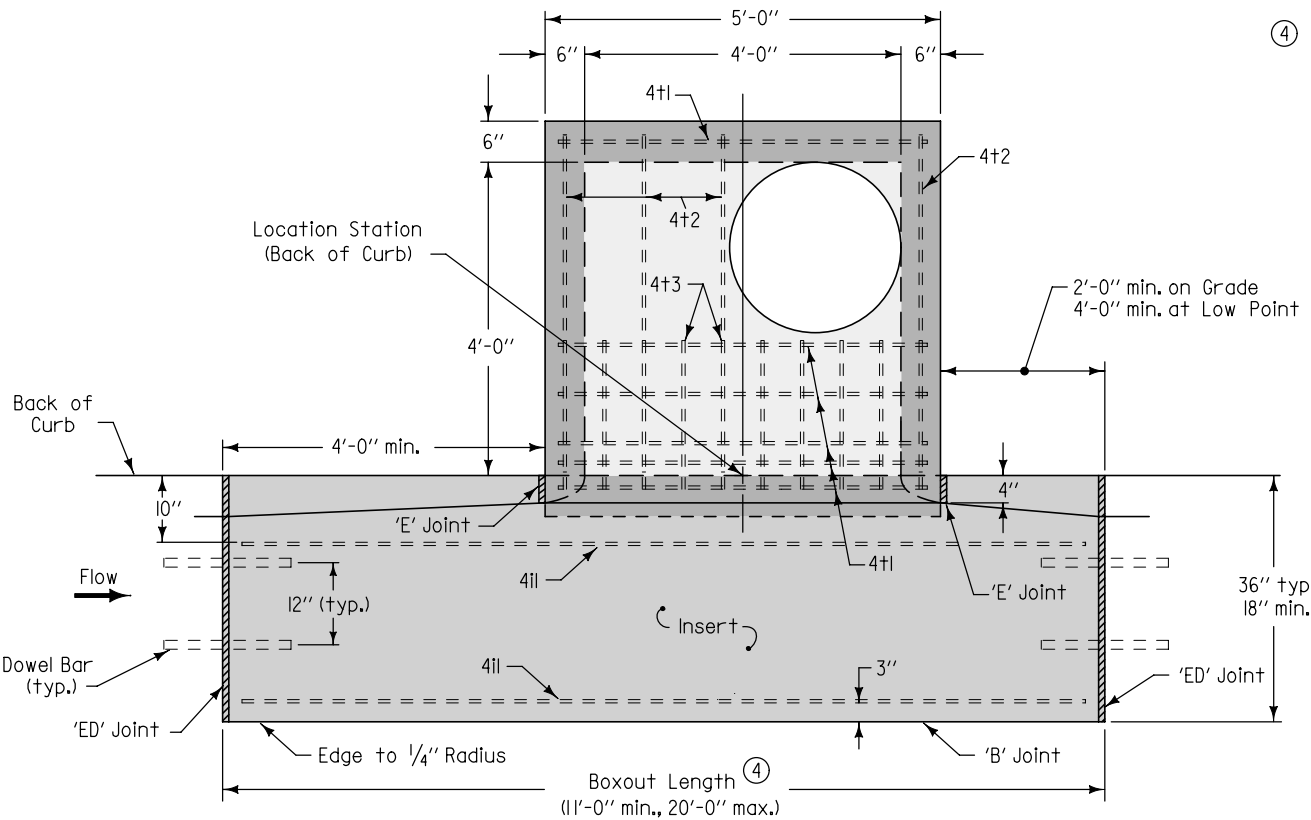

④ Transverse joint spacing on new concrete pavement is controlled by the intake boxout. Adjust adjacent joint spacing as required to accommodate boxouts.

For retrofit intakes, match existing pavement joints. Stop any transverse pavement joints that do not conform to the minimum spacing requirements at the edge of the insert area.

MAXIMUM PIPE DIAMETERS	
Precast Structure	Cast-in-place Structure
30"	36"

PLAN

REINFORCING BAR LIST						
Mark	Size	Location	Shape	Count	Length	Spacing
4t1	4	Top	—	7	4'-8"	See Insert
4t2	4	Top	—	4	4'-6"	12"
4t3	4	Top	—	10	1'-10"	6"
4b1	4	Base	—	6	4'-6"	11"
4b2	4	Base	—	6	4'-6"	11"
4il	4	Insert	—	4	Boxout Length minus 8"	See Plan
4w1	4	Walls	—	16	Wall Height minus 4"	14"
4w2	4	Walls	—	Varies	4'-8"	12"
4w3	4	Walls	—	Varies	4'-8"	12"

FIGURE 6010.508 SHEET 2 OF 2

SUDAS Iowa Department of Transportation	REVISION
	NEW 04-21-09
FIGURE 6010.508	STANDARD ROAD PLAN
SW-508	
SHEET 2 of 2	
REVISIONS: New. Replaces SUDAS Type "M-F" (Modified) Intake. Will replace RA-40.	
SUDAS DIRECTOR	DESIGN METHODS ENGINEER
SINGLE OPEN-THROAT INTAKE, LARGE BOX	