

### TYPE 4 GRATES

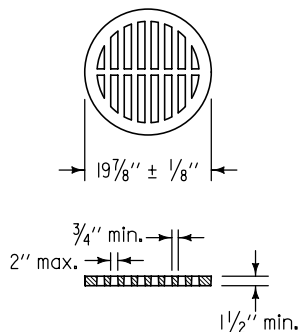

**TYPE 4A**  
For Placement on 18" RCP

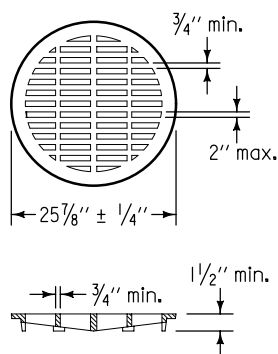

**TYPE 4B**  
For Placement on 24" RCP

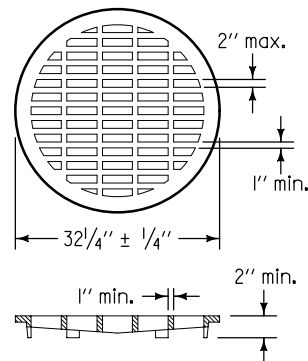

**TYPE 4C**  
For Placement on 30" RCP

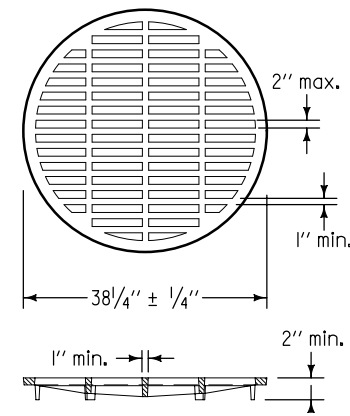

**TYPE 4D**  
For Placement on 36" RCP

### TYPE 3 GRATES (Light Duty)

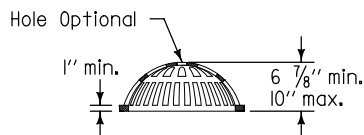
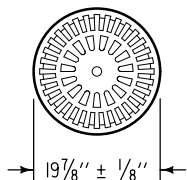

**TYPE 3A**  
For Placement on 18" RCP

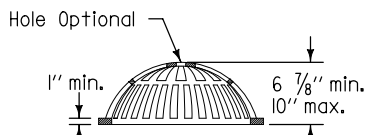
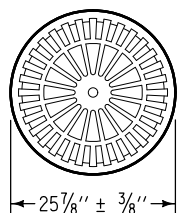

**TYPE 3B**  
For Placement on 24" RCP

### TYPE 5 GRATE (Light Duty) For Placement on 24" to 30" RCP

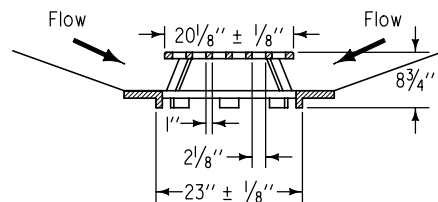
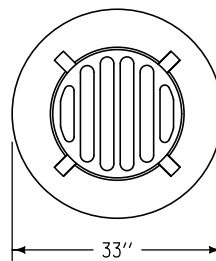

### TYPE 6 GRATE

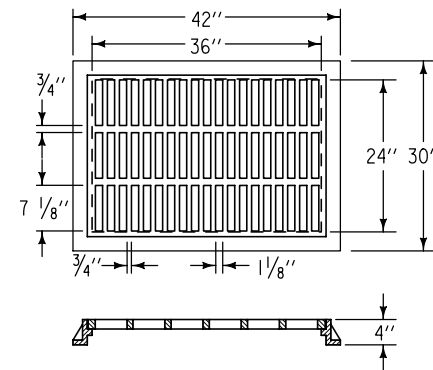

FIGURE 6010.604 SHEET 1 OF 1

		REVISION
		NEW 04-21-09
<b>FIGURE 6010.604</b>	<b>STANDARD ROAD PLAN</b>	<b>SW-604</b>
REVISIONS: New. Replaces SUDAS Figure 6030.15.		SHEET 1 of 1
SUDAS DIRECTOR		DESIGN METHODS ENGINEER

**CASTINGS FOR AREA INTAKES**