

SITUATION 1 (RURAL)

Project Route Closure

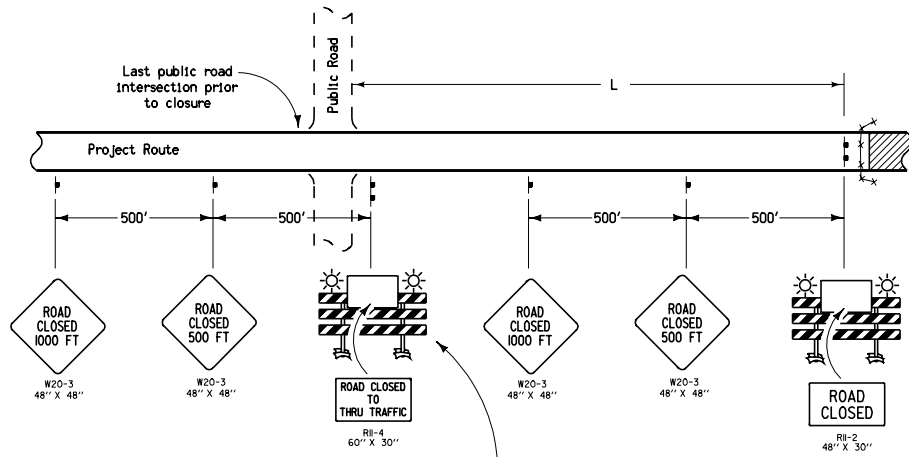

Where L distance is less than 1000',
move this barricade to the center
of the traffic lane.

SITUATION 1 (URBAN)

Project Route Closure

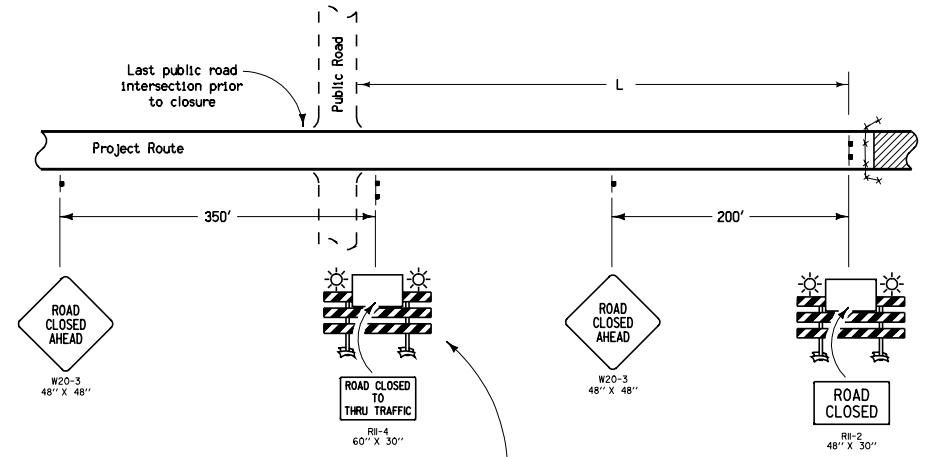

Where L distance is less than 500',
move this barricade to the center
of the traffic lane.

LEGEND

- Traffic Sign
- Type III Barricade
- Orange Mesh Safety Fence
- Type 'A' Low-Intensity Flashing Warning Light
- Work Area

Contract Item:
Traffic Control
Safety Closures

Tabulation:
108-13A

Iowa Department
of Transportation

STANDARD ROAD PLAN

REVISIONS: Modified speed limit table variable. Revorded circle note 1.

Deanna Macfadyen
APPROVED BY DESIGN METHODS ENGINEER

ROAD CLOSURE

REVISION	1	04-15-08
TC-252		
SHEET 1 of 2		

SITUATION 2

Public cross-traffic maintained.
No access to project.

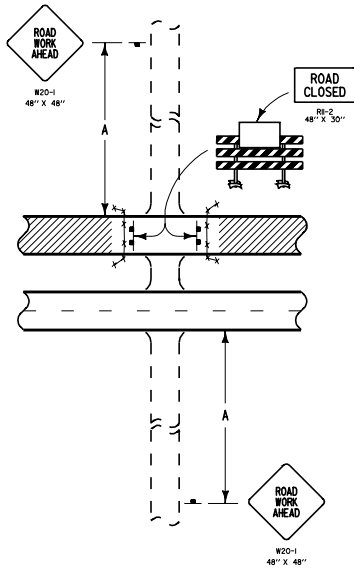

SITUATION 3

No access to project
(Applicable to T-Intersections)

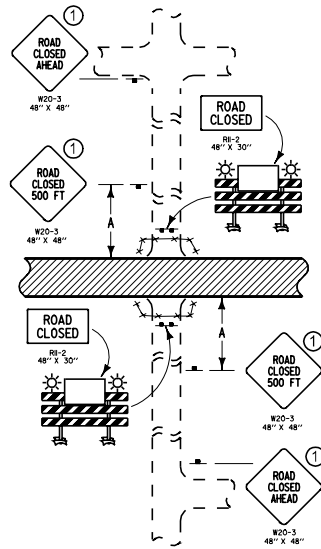

SITUATION 4

Public cross-traffic maintained.
No access to project.

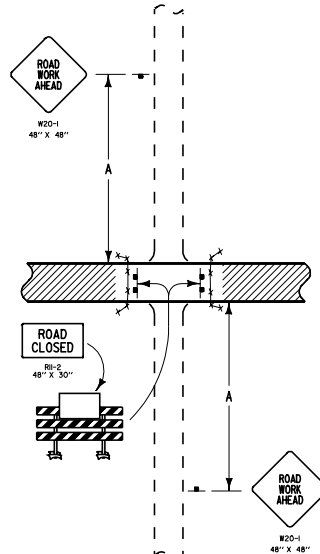

SITUATION 5

Public cross-traffic maintained.
Contractor and resident access.

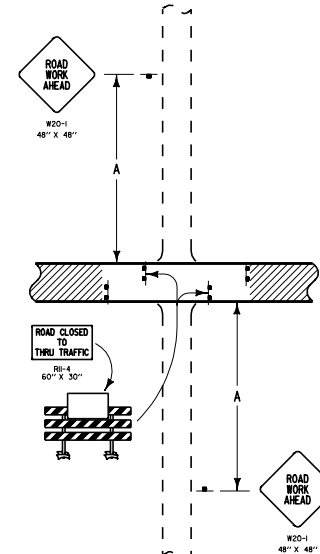

SITUATION 6

No public access. Contractor and resident
access only. (Applicable to T-Intersections)

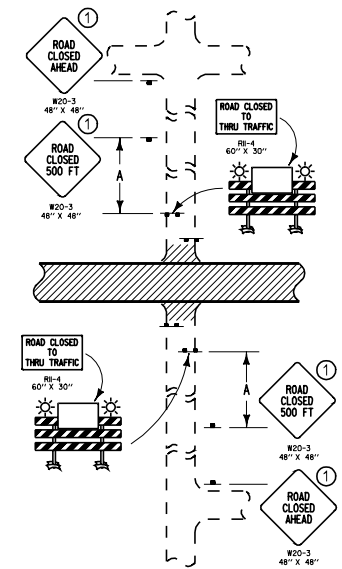

LEGEND

- Traffic Sign
- Type III Barricade
- Orange Mesh Safety Fence
- Type 'A' Low-Intensity Flashing Warning Light
- Work Area

Location	A
Urban	200'
Rural	500'

During suspension of work, (such as over winter):

- Use Situation 2 on two-lane to four-lane projects.
- Situation 5 is preferred where cross-traffic is maintained.

① In urban locations, remove the ROAD CLOSED 500 FT sign and replace it with the ROAD CLOSED AHEAD sign.

Iowa Department of Transportation STANDARD ROAD PLAN	REVISION 1 04-15-08
	TC-252 SHEET 2 of 2
REVISIONS: Modified speed limit table variable. Reversed circle note 1.	
APPROVED BY DESIGN METHODS ENGINEER <i>Deanna Macfadyen</i>	
ROAD CLOSURE	