

PLAN VIEW

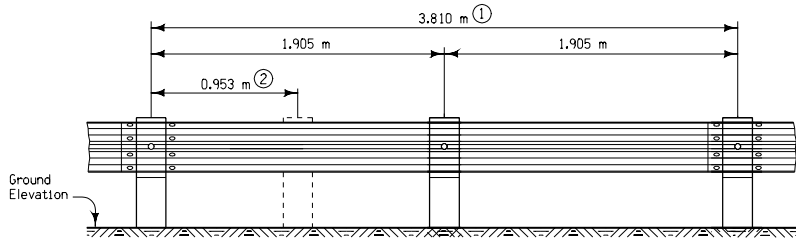

ELEVATION

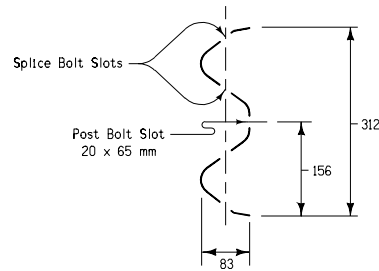

SECTION THRU RAIL

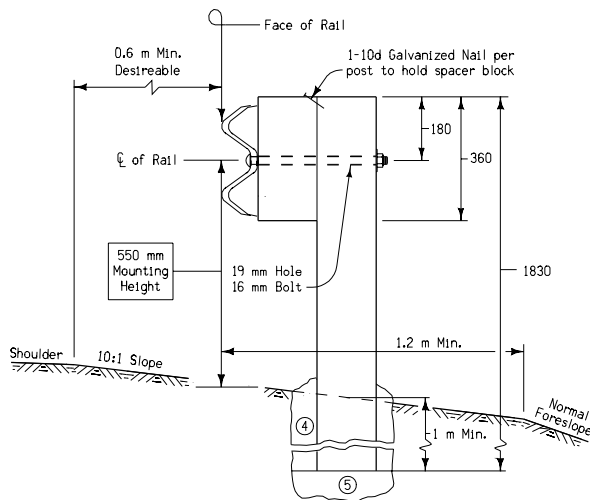

DETAILS OF POST AND SPACER BLOCK

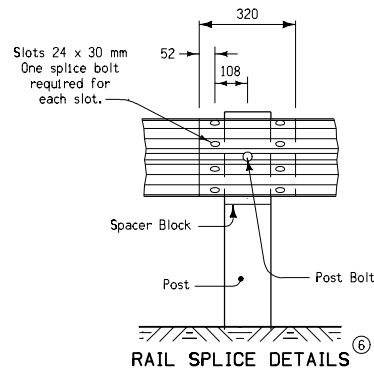

RAIL SPLICE DETAILS

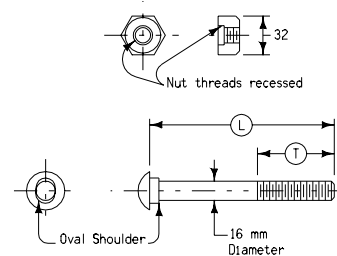

DETAILS OF HARDWARE

BOLT LENGTH TABLE			
Wood Post	T	L	
200 mm Single Spacer	100	460	
200 mm Double Spacer	100	640	
Splice Bolt	30	35	

L = Min. Length of Bolt (3)
 T = Min. Thread Length

GENERAL NOTES:

All beam rail installed on curvilinear alignment of a radius less than 45 meters shall be shop curved to the proper radius by the fabricator.

A splice in the beam railing shall occur only at a post location. The Engineer may modify the length of beam railing or number of posts required. Any such adjustment shall be compensated for at the contract price.

When the removal of traffic markers, barriers or warning devices is necessary for proper installation of guardrail or end anchorage, they shall be removed at the direction of the Engineer. Removal of these devices shall require temporary warning markers, provided by the Contractor, if not reinstalled on the same day as construction begins.

- ① Unless specified otherwise, rail elements may be furnished in either 7.620 meter or 3.810 meter sections.
- ② A 0.953 meter post spacing may be required where space for guardrail deflection is limited. Refer to Standard Road Plans for specific requirements.
- ③ For any case requiring bolt other than as indicated, the bolt lengths shall be of proper length to accomplish the intended purpose.
- ④ When guardrail posts are to be installed in HMA or PCC shoulders, the Contractor will be required to predrill or cut holes of equal diameter for posts. Where drilled post holes are used, they shall be backfilled and tamped with material removed from the holes unless specified otherwise.
- ⑤ Any over-depth portion of hole shall be backfilled with sand and firmly tamped.
- ⑥ Splice lap direction shall be as specified on detail project plans and appropriate Standard Road Plans.

All dimensions given in millimeters unless noted.

METRIC VERSION	Iowa Department of Transportation Highway Division	
	STANDARD ROAD PLAN RE-12A	
	REVISION: Remove Hardware Information Already in the Specifications Book.	REVISION NO. 6
	<i>William J. Sten</i> APPROVED BY DESIGN METHODS ENGINEER	
	REVISION DATE 10-19-04	
FORMED STEEL BEAM GUARDRAIL AND POSTS FOR BLOCKED-OUT GUARDRAIL (W-BEAM)		