

**TYPE Q** <sup>①</sup>  
 Driveway Gate  
 (Minimum open area 370 in<sup>2</sup>)

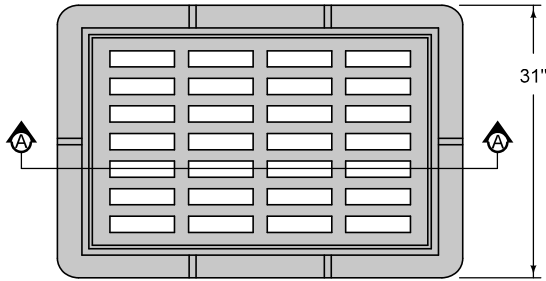

PLAN

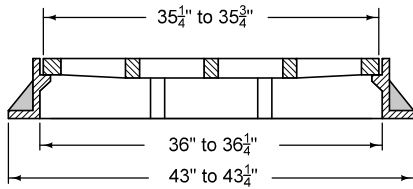

SECTION A-A

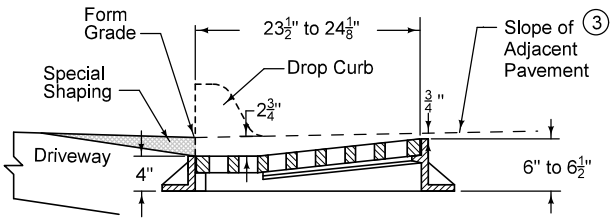

TYPICAL SECTION

**TYPE R** <sup>②</sup>  
 Curb Inlet Gate  
 (Minimum open area 180 in<sup>2</sup>)

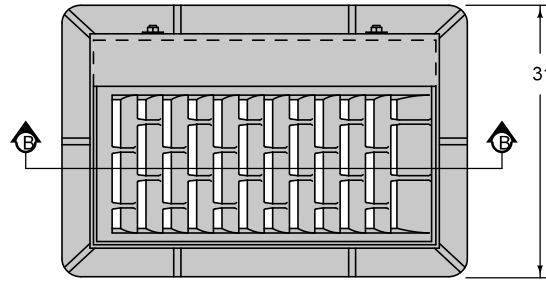

PLAN

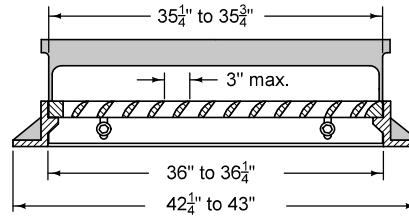

SECTION B-B

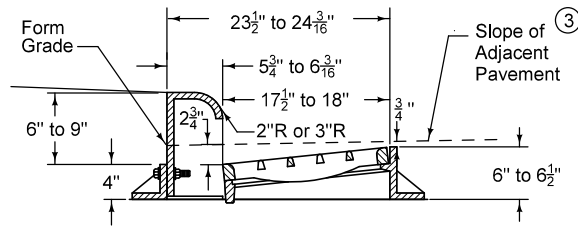

TYPICAL SECTION

- ① For use at curb drops for driveways. Use only when specified in the contract documents.
- ② Provide bicycle-safe vane-style grate. At low points, grates with vanes facing both directions of flow are allowed.
- ③ For details of boxout pavement, refer to SW-514.

FIGURE 6010.603 SHEET 1 OF 2

SUDAS IOWADOT	REVISION
	6 10-16-18
FIGURE 6010.603	STANDARD ROAD PLAN
Paul D. Wigand SUDAS DIRECTOR	
Brian Smith DESIGN METHODS ENGINEER	
<b>CASTINGS FOR GRATE INTAKES</b>	

**TYPE S** ②④  
 Barrier Intake Gate  
 (Minimum open area 300 in<sup>2</sup>)

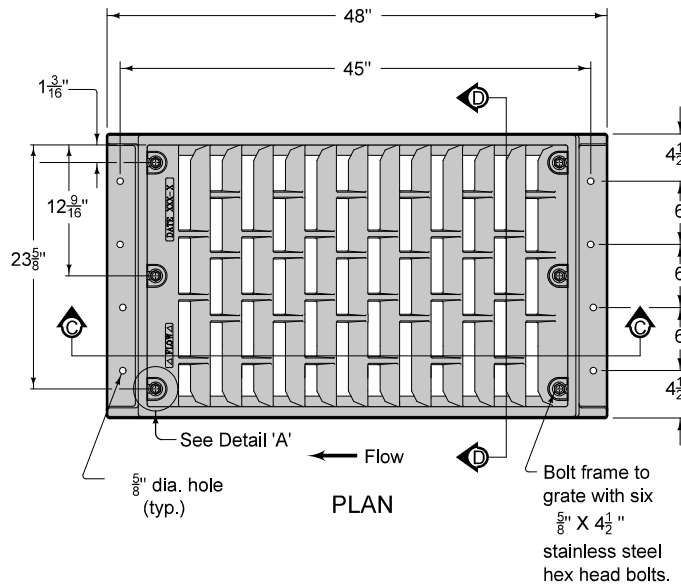
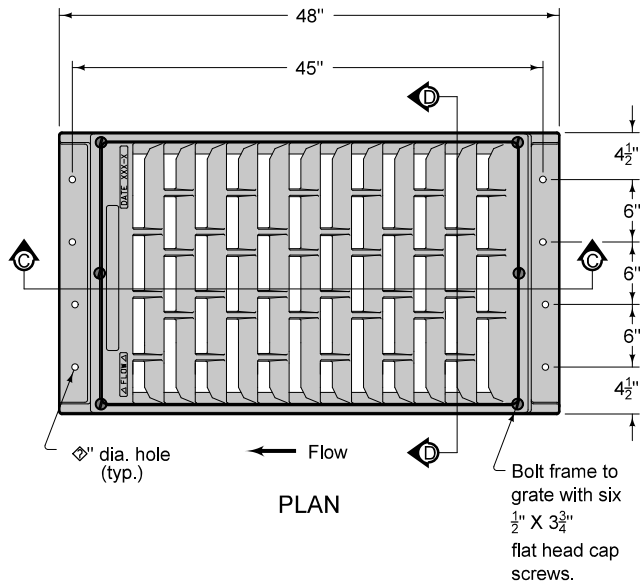

- ② Provide bicycle-safe vane-style grate. At low points, grates with vanes facing both directions of flow are allowed. The Contractor has the choice of which Type S Gate to use.
- ④ Use ductile iron frame castings meeting the requirements of ASTM A 536.

Frame minimum weight = 220 lbs.  
 Grate minimum weight = 340 lbs.

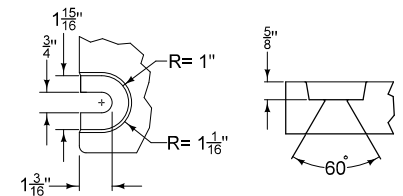

DETAIL 'A'  
 Bolt Slot Detail

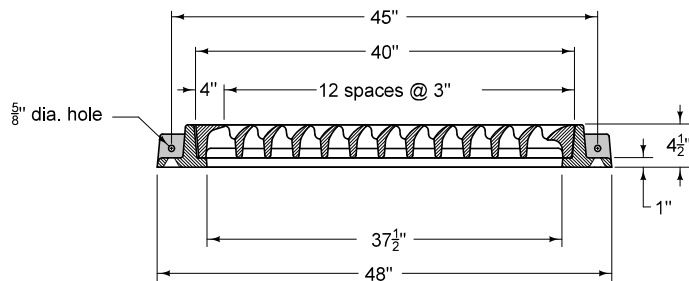

SECTION C-C

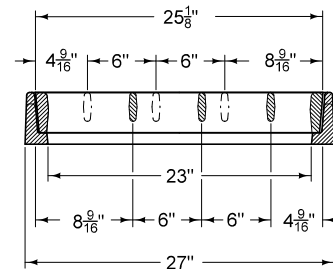

SECTION D-D

FIGURE 6010.603 SHEET 2 OF 2

SUDAS	IOWADOT	REVISION
		6 10-16-18
FIGURE 6010.603	STANDARD ROAD PLAN	SW-603
		SHEET 2 of 2
REVISIONS: Corrected typo on page two that said SHEET 1 of 2.		
Paul D. Wigand SUDAS DIRECTOR		Brian Smith DESIGN METHODS ENGINEER
<b>CASTINGS FOR GRATE INTAKES</b>		