

Table of Contents

Chapter 1 - Regulations, Administration, and Policies

- 1.1 Purpose of Manual
 - 1.1.1 Bridge Terminology Figures
- 1.2 History and Requirements of National Bridge Inspection Standards
 - 1.2.1 History and Background of NBIS
 - 1.2.2 Bridge Inspection Organization
 - 1.2.3 Required Qualifications of Bridge Inspection Personnel
 - 1.2.4 Bridge Inventory Requirements
- 1.3 Types of Inspections and Intervals
 - 1.3.1 Initial Inspections (1)
 - 1.3.2 Routine Inspections (2)
 - 1.3.3 Underwater Inspections (3)
 - 1.3.4 Nonredundant Steel Tension Member NSTM Inspections (4)
 - 1.3.5 Damage Inspections (5)
 - 1.3.6 In-Depth Inspections (6)
 - 1.3.7 Special Inspections (7)
 - 1.3.8 Scour Monitoring Inspections (8)
- 1.4 Iowa DOT Inspection Program Policies
 - 1.4.1 Safety
 - 1.4.2 Media Relations
- 1.5 Statewide Inspection Program Policies
 - 1.5.1 Timelines for Completion of Inspections and Reports
 - 1.5.2 Standardized Bridge Orientation and Labeling Conventions
 - 1.5.3 Critical Findings/Emergency Response
 - 1.5.4 Inspection Intervals for Non-Regulated Structures
 - 1.5.5 Temporary Structures
 - 1.5.6 Temporary Supports

CHAPTER 1

REGULATIONS, ADMINISTRATION, AND POLICIES

1.1 PURPOSE OF MANUAL

The purpose of this manual is to organize, document, and combine Iowa Department of Transportation (Iowa DOT) policies and procedures for bridge inspection practices and post-inspection recommendations so Iowa DOT personnel, local agencies, and consultants will have a readily available resource for their use. As in every state, the proper inspection of bridges is a top priority for Iowa DOT to ensure the safety of our state's bridges. This manual is intended to ensure uniformity and to document the best practices for inspecting Iowa's bridges.

The Iowa Bridge and Structures Bureau has established these goals:

- Assure the safety of our transportation customers on bridges
- Achieve and maintain compliance with the NBIS, assuring eligibility for Federal-Aid Funds
- Identify deficiencies to initiate maintenance and support the identification of project needs
- Provide accurate and reliable data to support sound asset management of Iowa DOT's bridge inventory

Relevant definitions, abbreviations, and acronyms may be found in Appendices.

Chapter 1 Introduction:

The purpose of this chapter is to provide bridge terminology through the use of isometric diagrams of the most common types of bridge structures found in Iowa. This chapter will also discuss the history and background of the NBIS, including incidents that shaped some of the regulations and requirements for bridge safety inspection over the past four decades. The responsibilities of the bridge inspection organization are listed along with the personnel qualification requirements in compliance with 23 CFR Part 650 Subpart C sections 650.307 and 650.309. The Structure Inventory and Inspection Management System (SIIMS) to maintain its bridge inventory is introduced. The nine types of inspections, including subsets, are defined and described to align with the SNBI coding B.IE.01 "Inspection Type." Inspection intervals and requirements for each are covered. Iowa DOT statewide policies related to safety, media relations, timelines for completion of inspections and reporting, bridge orientation and labeling conventions, critical findings and emergency response are also provided. Non-regulated structures, such as pedestrian bridges, culverts less than 20 feet in length, and privately owned bridges are identified. Lastly, temporary bridge coding requirements are provided.

1.1.1 Bridge Terminology Figures

Figures 1.1.1.1 through 1.1.1.18 are provided to standardize the terminology and labeling of bridge components used in bridge inspection reports. The bridges depicted represent the majority of bridge types used throughout the State of Iowa (State), both on the Primary highway system and the Secondary highway system.

1.1.1.1 Timber Stringer Bridge

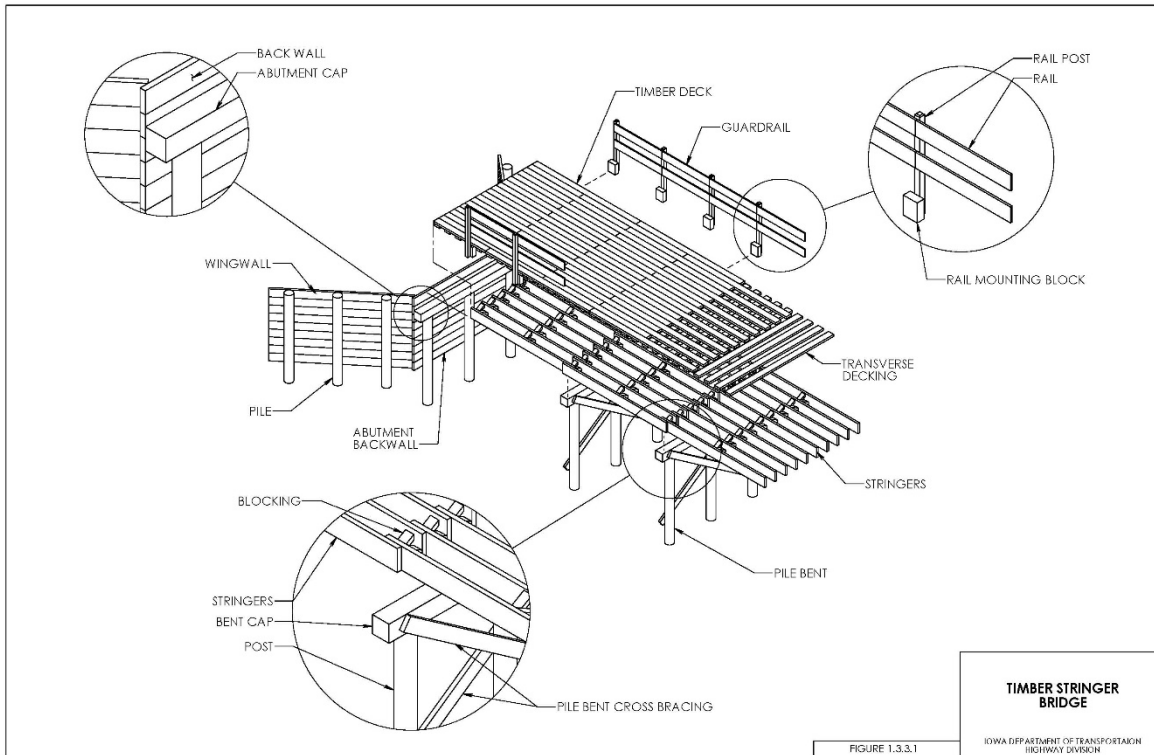

Figure 1.1.1-1 Timber Stringer Bridge Components

1.1.1.2 Reinforced Concrete Slab Bridge

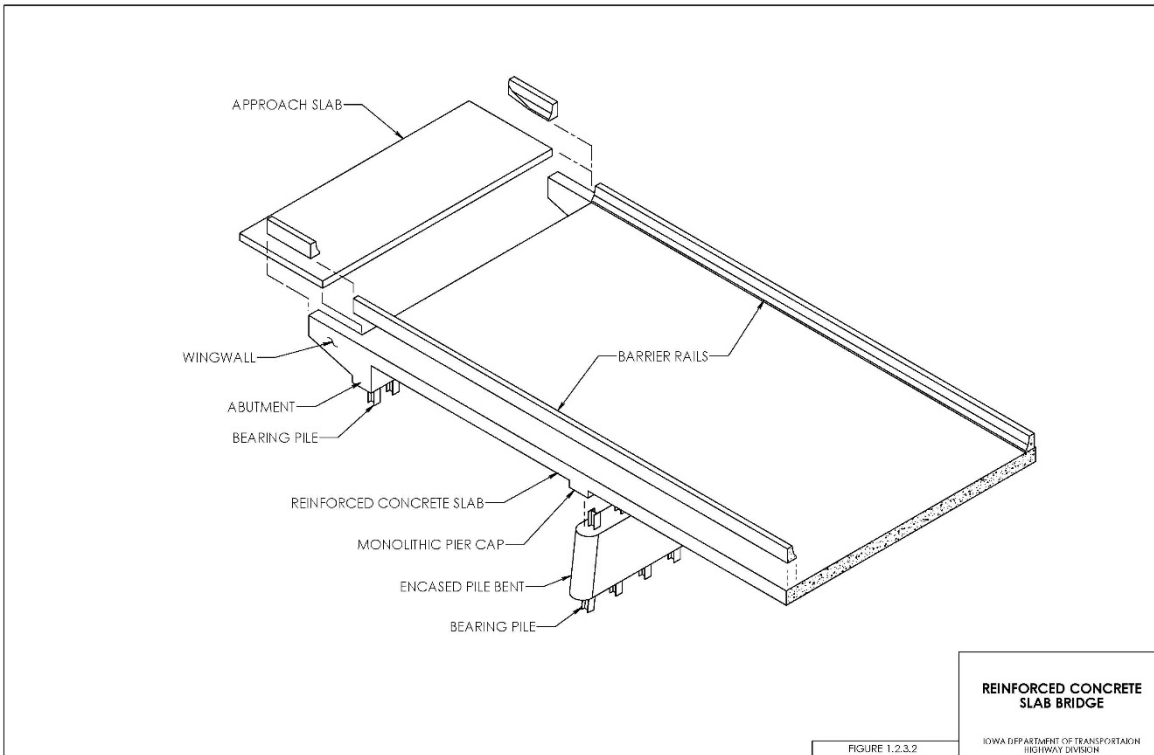

Figure 1.1.1-2 Reinforced Concrete Slab Bridge Components

1.1.1.3 Reinforced Concrete Beam Bridge

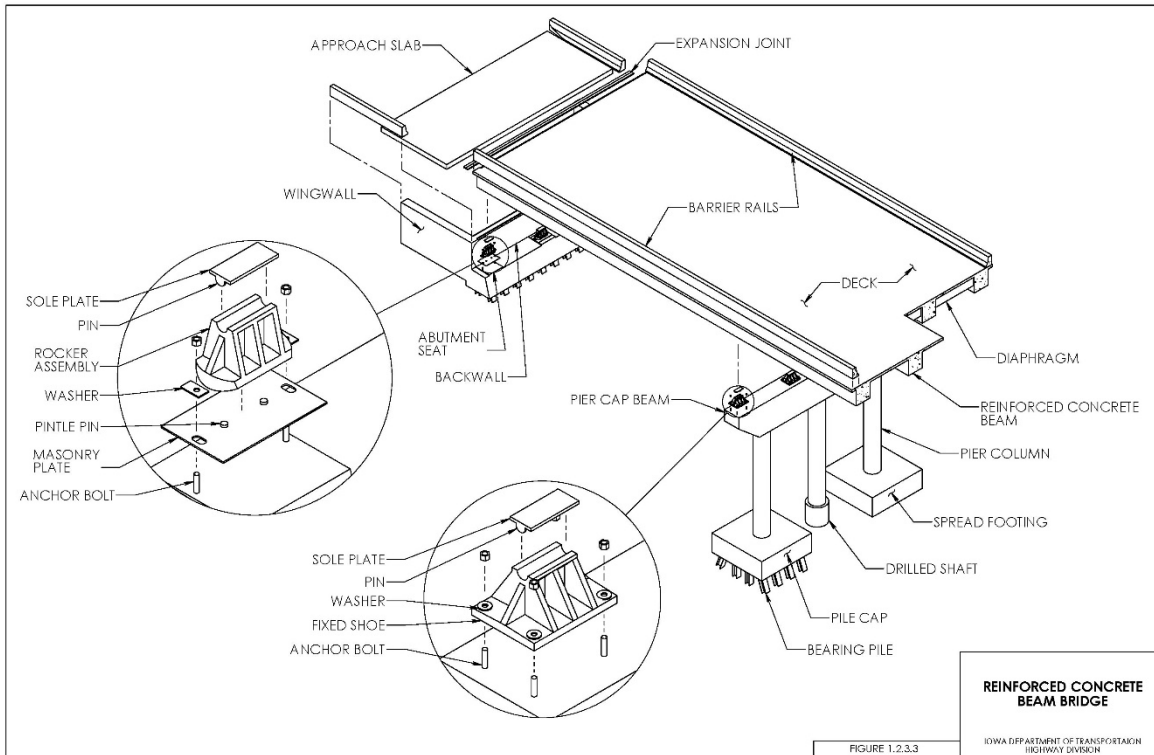

Figure 1.1.1-3 Reinforced Concrete Beam Bridge Components

1.1.1.4 Prestressed Concrete Beam Bridge

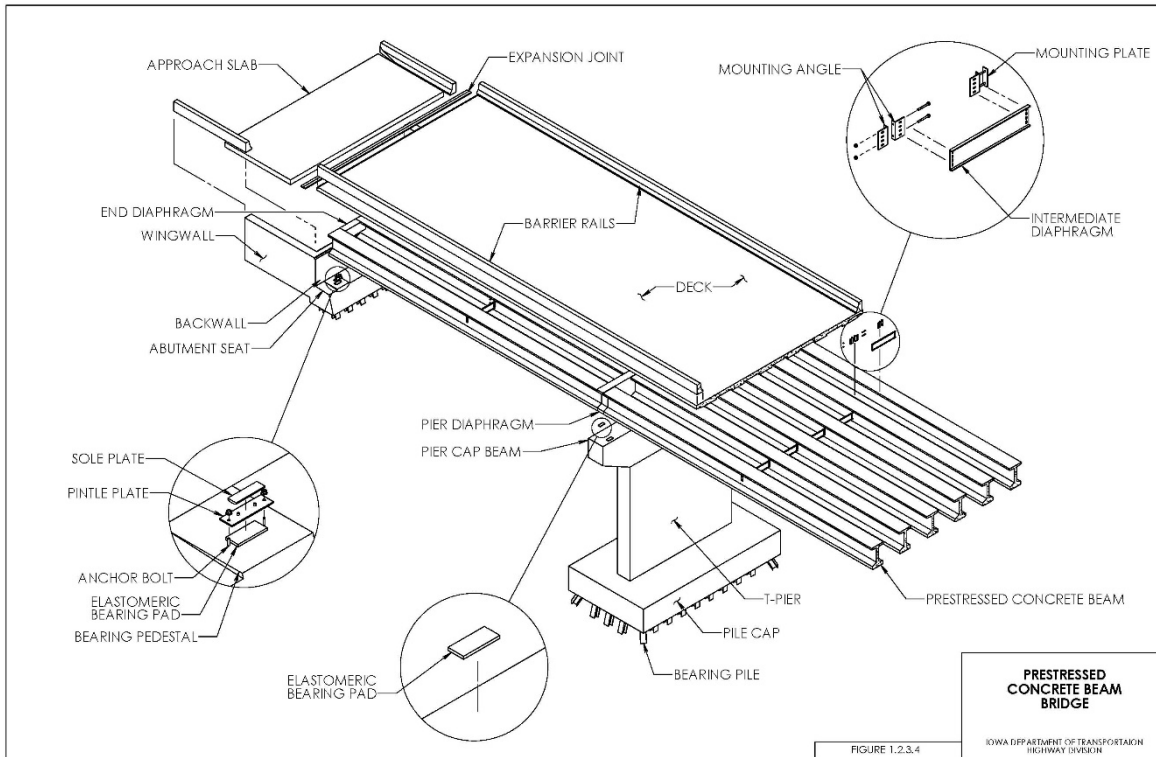

Figure 1.1.1-4 Prestressed Concrete Beam Bridge Components

1.1.1.5 Prestressed Concrete Quad Tee Beam Bridge

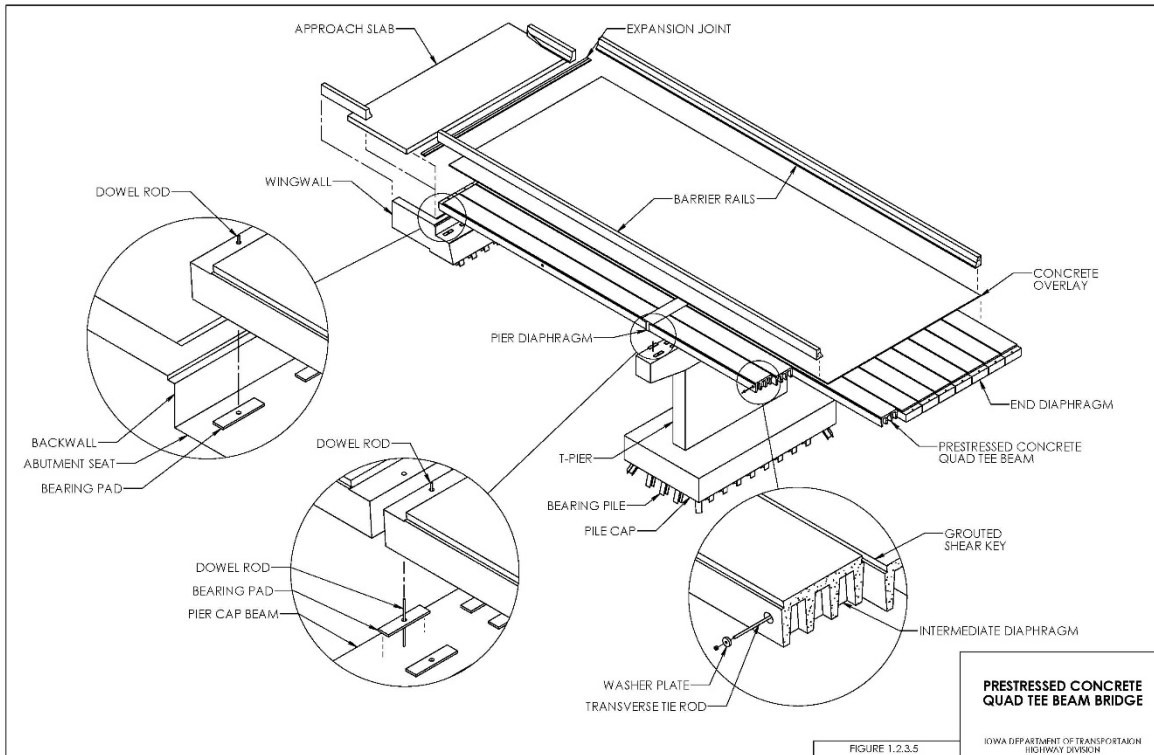

Figure 1.1.1-5 Prestressed Concrete Quad Tee Beam Bridge Components

1.1.1.6 Precast Concrete Box Beam Bridge

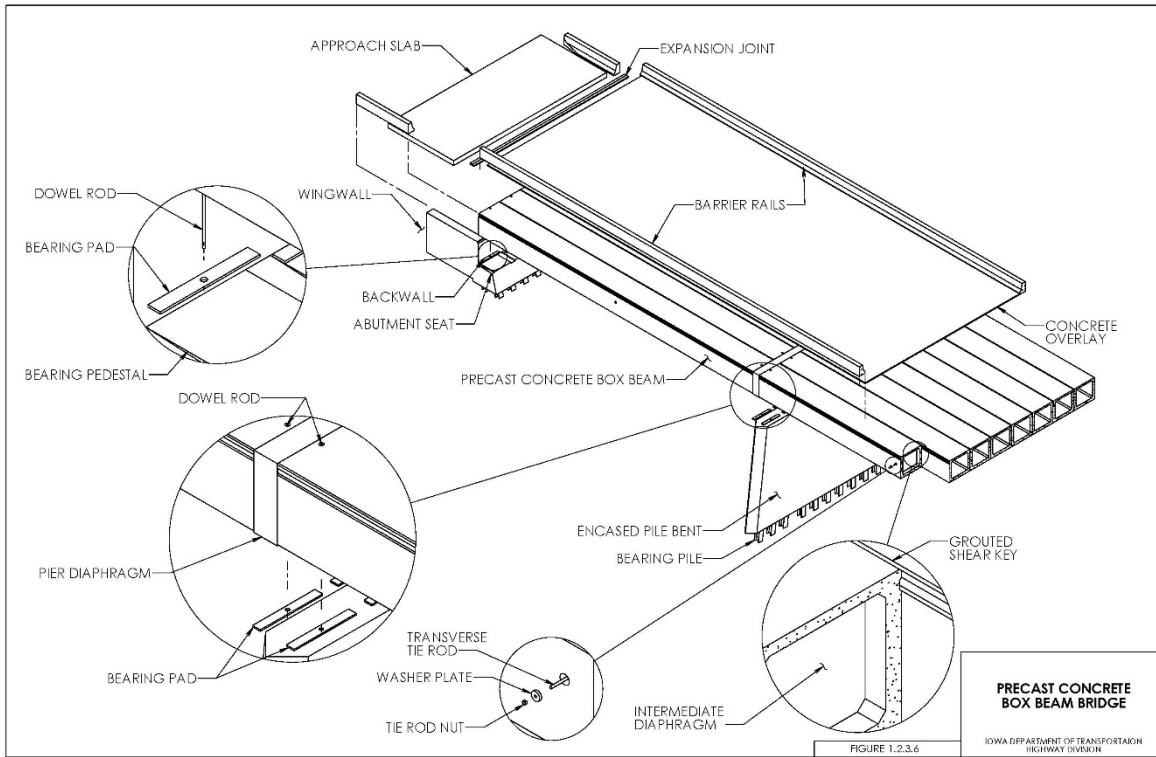

Figure 1.1.1-6 Precast Concrete Box Beam Bridge Components

1.1.1.7 Precast Concrete Panel Beam Bridge

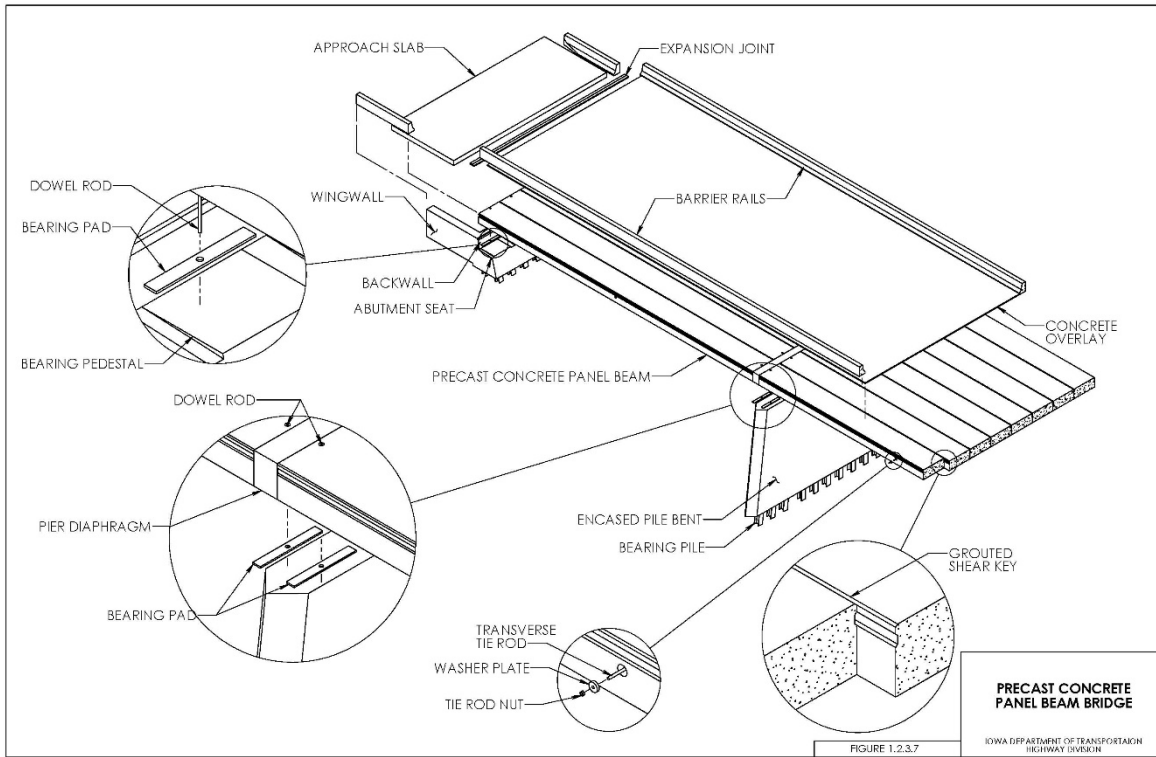

Figure 1.1.1-7 Precast Concrete Panel Beam Bridge Components

1.1.1.8 Precast Concrete Channel Beam Bridge

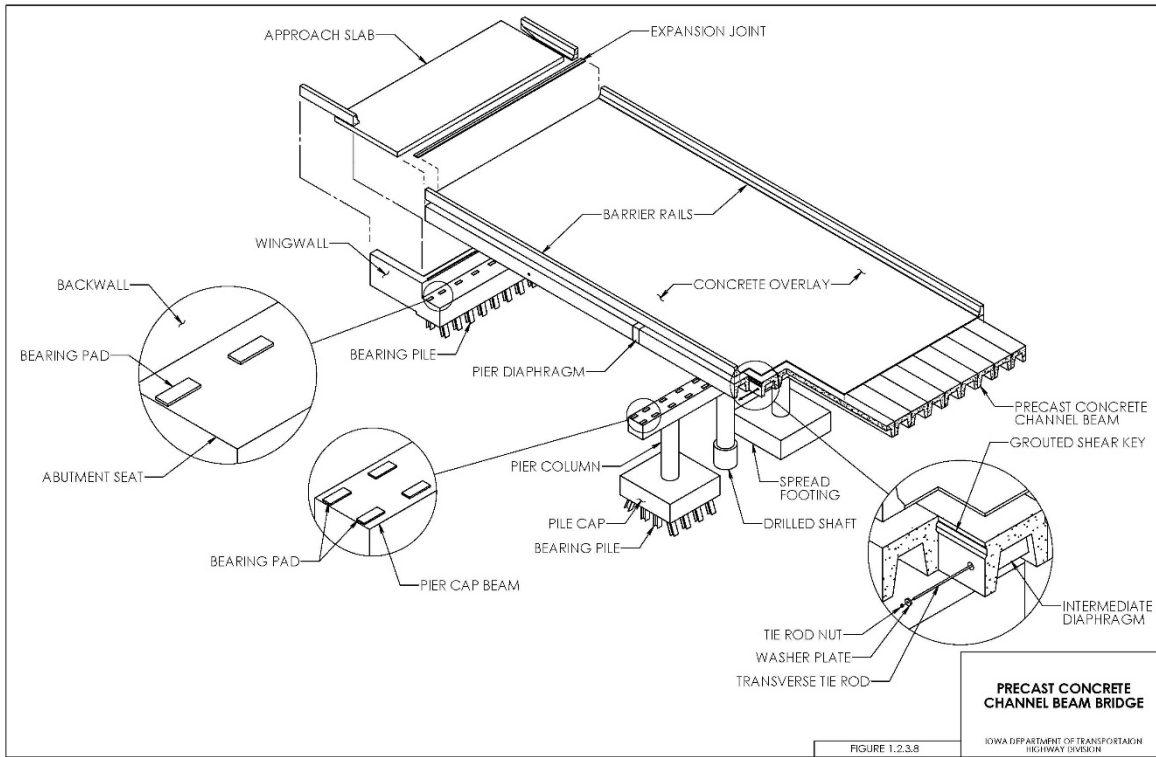

Figure 1.1.1-8 Precast Concrete Channel Beam Bridge Components

1.1.1.9 Steel Rolled Beam or Welded Steel Plate Girder Bridge

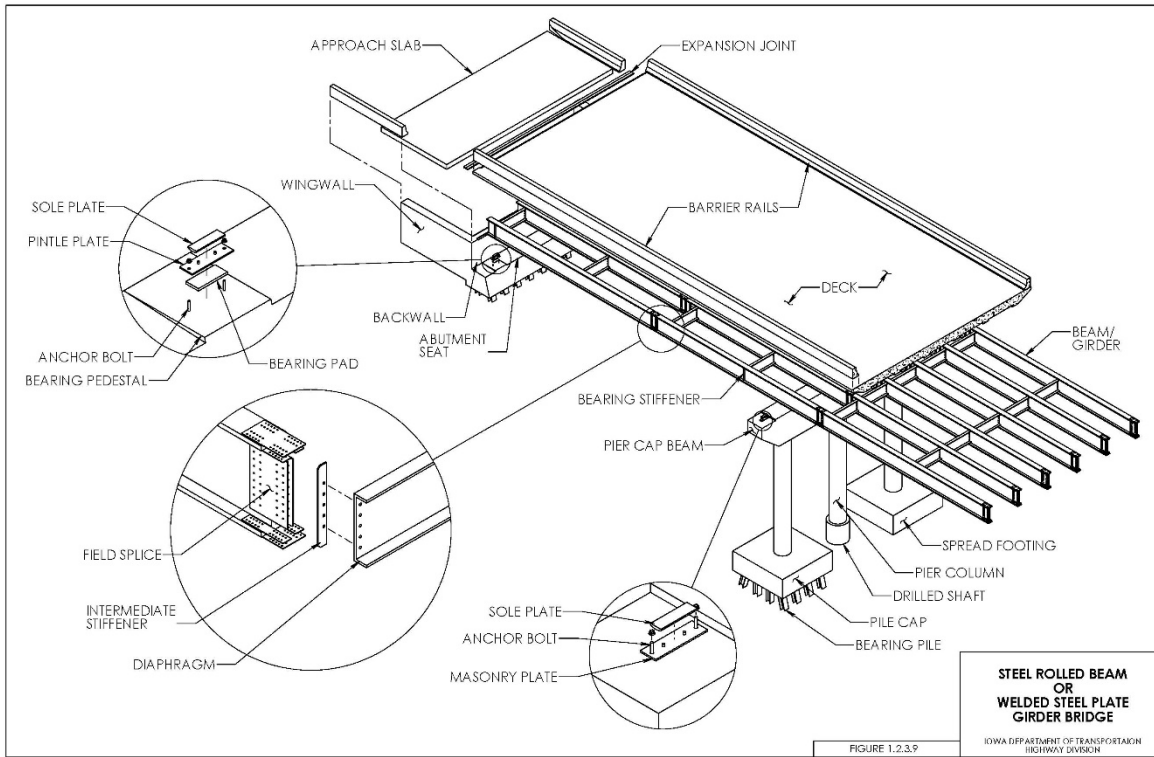

Figure 1.1.1-9 Steel Rolled Beam or Welded Steel Plate Girder Bridge Components

1.1.1.10 Steel Girder and Floorbeam Bridge

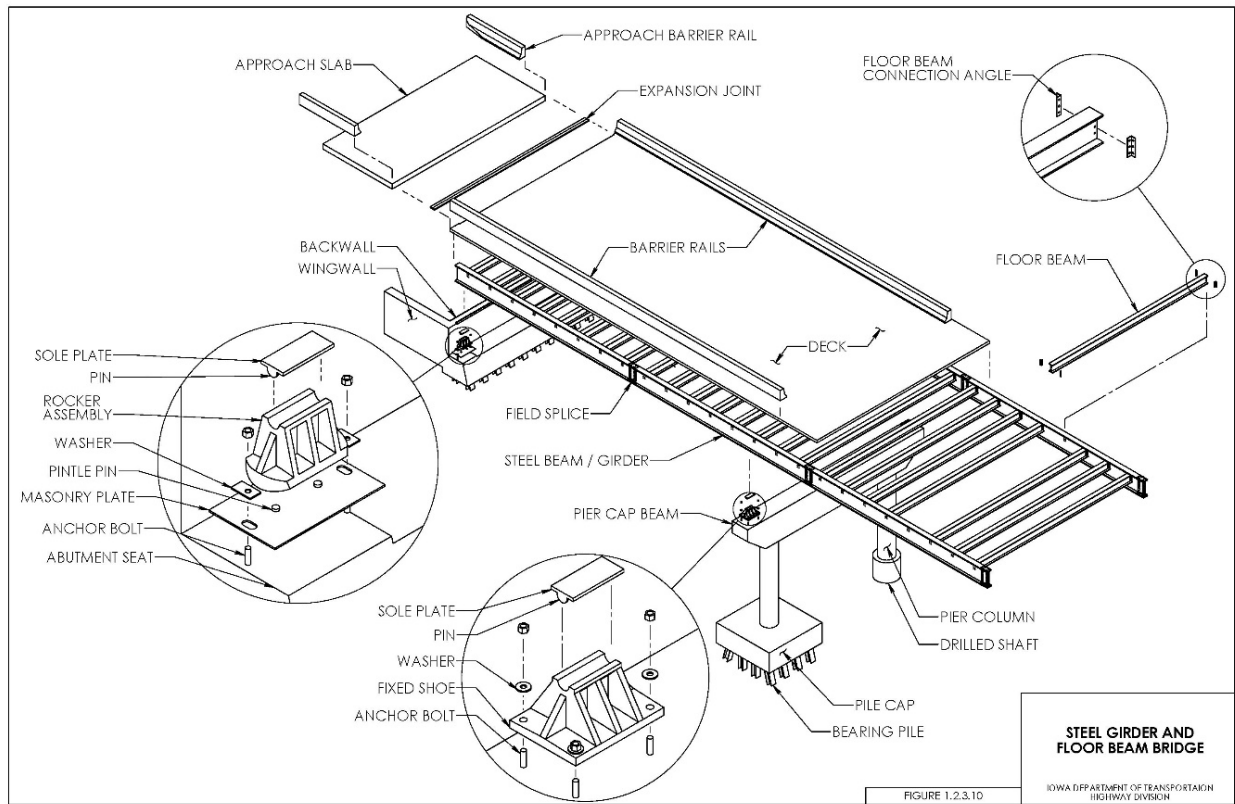

Figure 1.1.1-10 Steel Girder and Floorbeam Bridge Components

1.1.1.11 Two Girder, Floorbeam and Stringer System

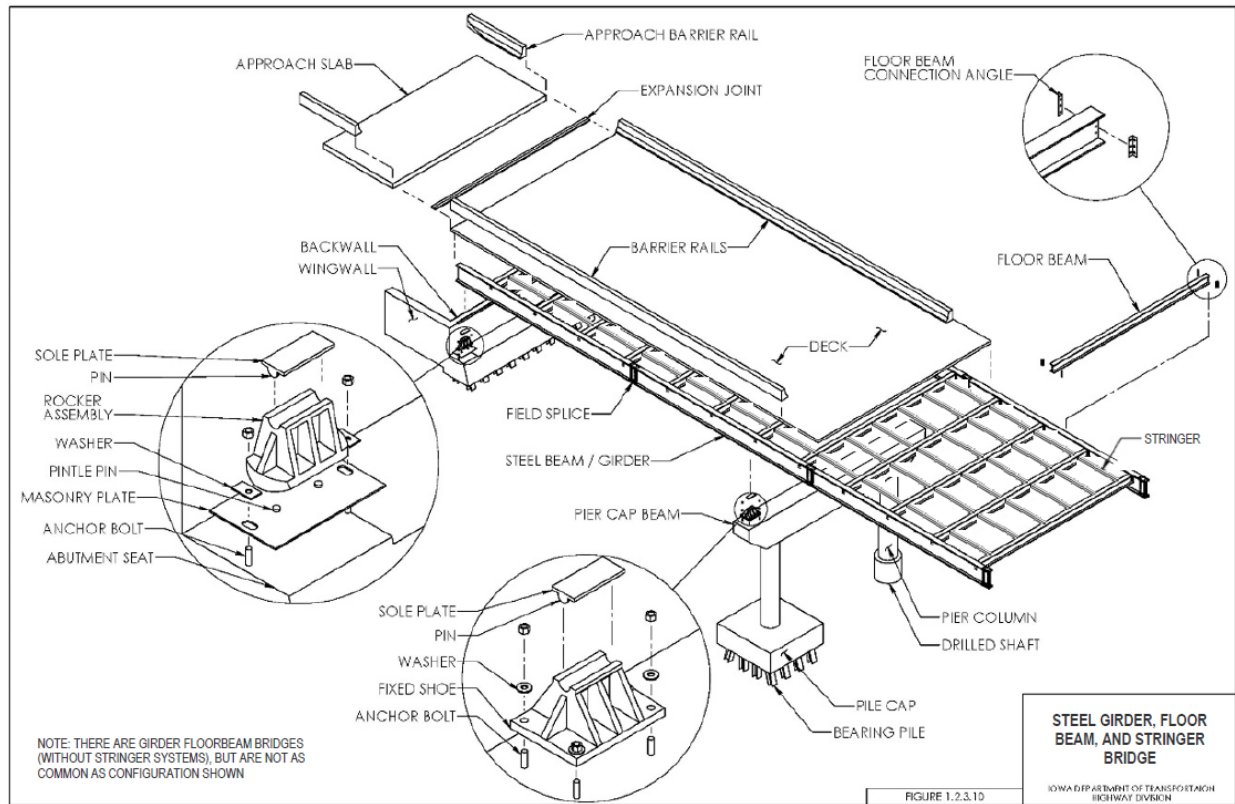

Figure 1.1.1-11 Two Girder, Floorbeam and Stringer System Components

1.1.1.12 Steel Truss Bridge

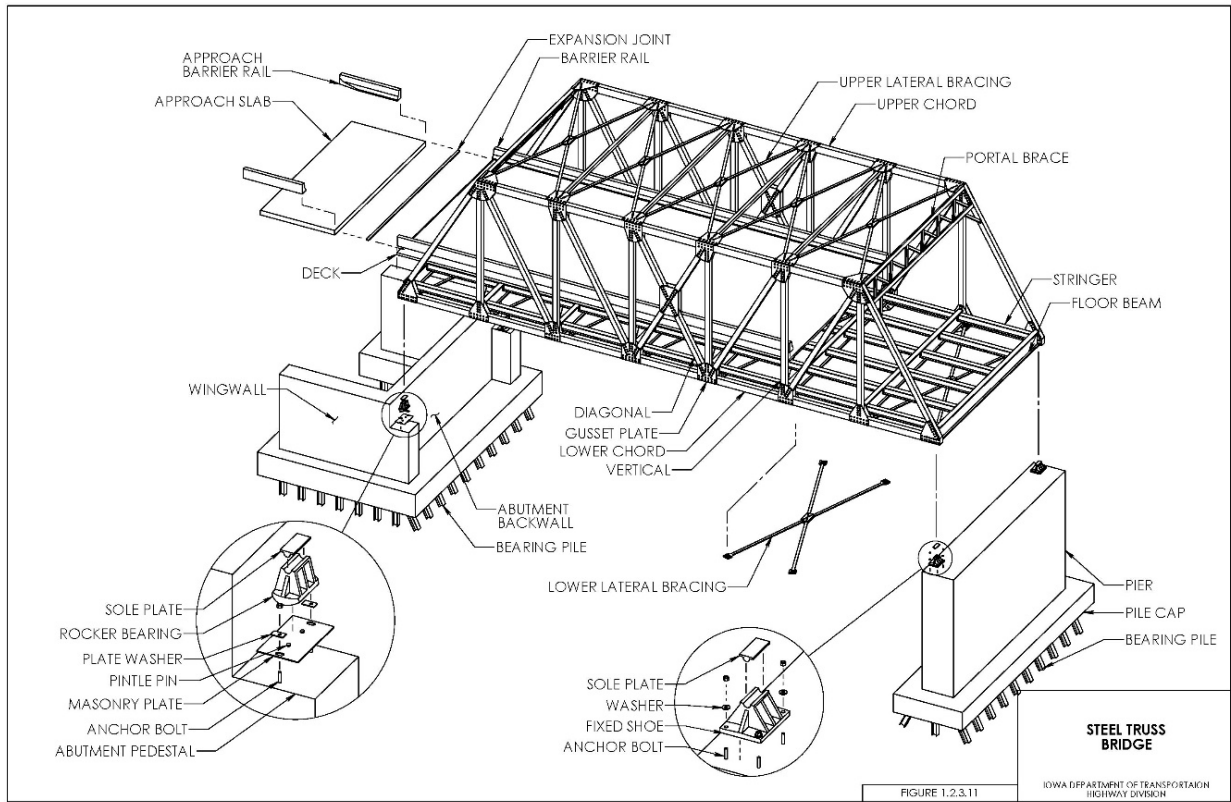

Figure 1.1.1-12 Steel Truss Bridge Components

1.1.1.13 Steel Tied Arch Bridge

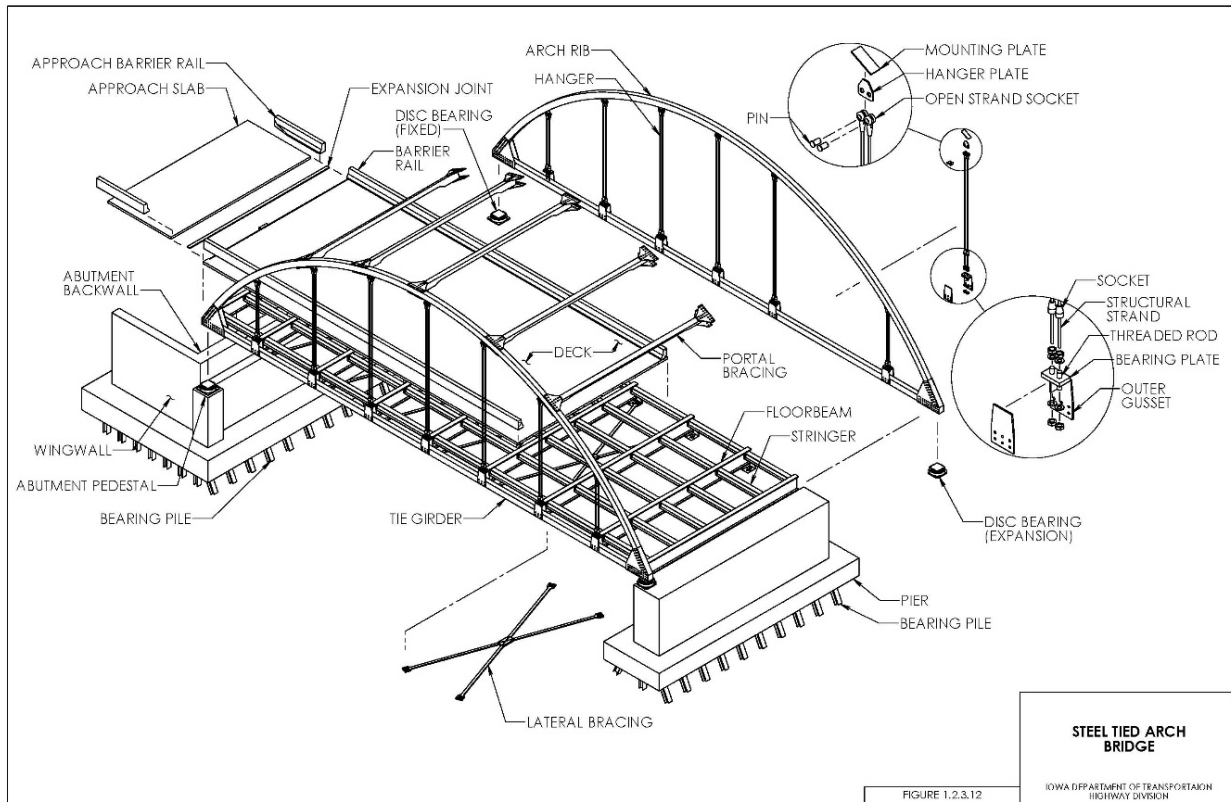

Figure 1.1.1-13 Steel Tied Arch Bridge Components

1.1.1.14 Steel True Arch Bridge

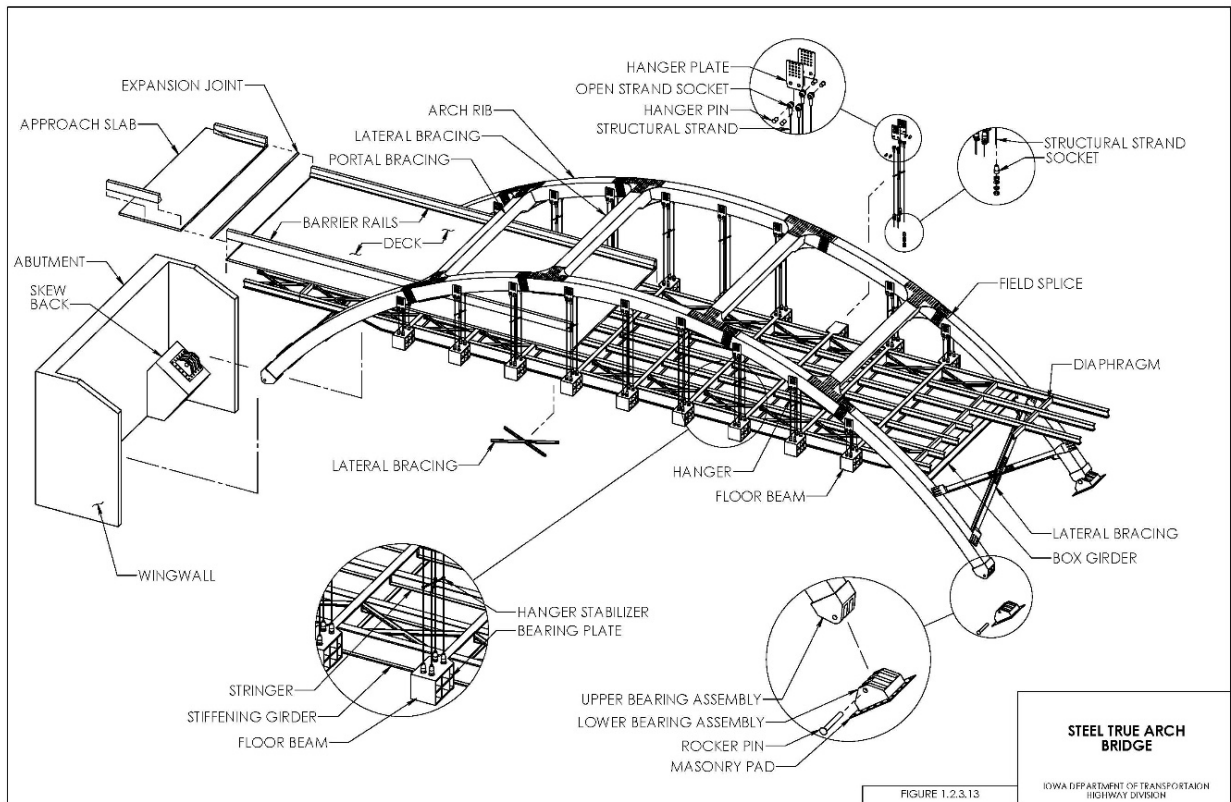

Figure 1.1.1-14 Steel True Arch Bridge Components

1.1.1.15 Concrete Spandrel Arch Bridge

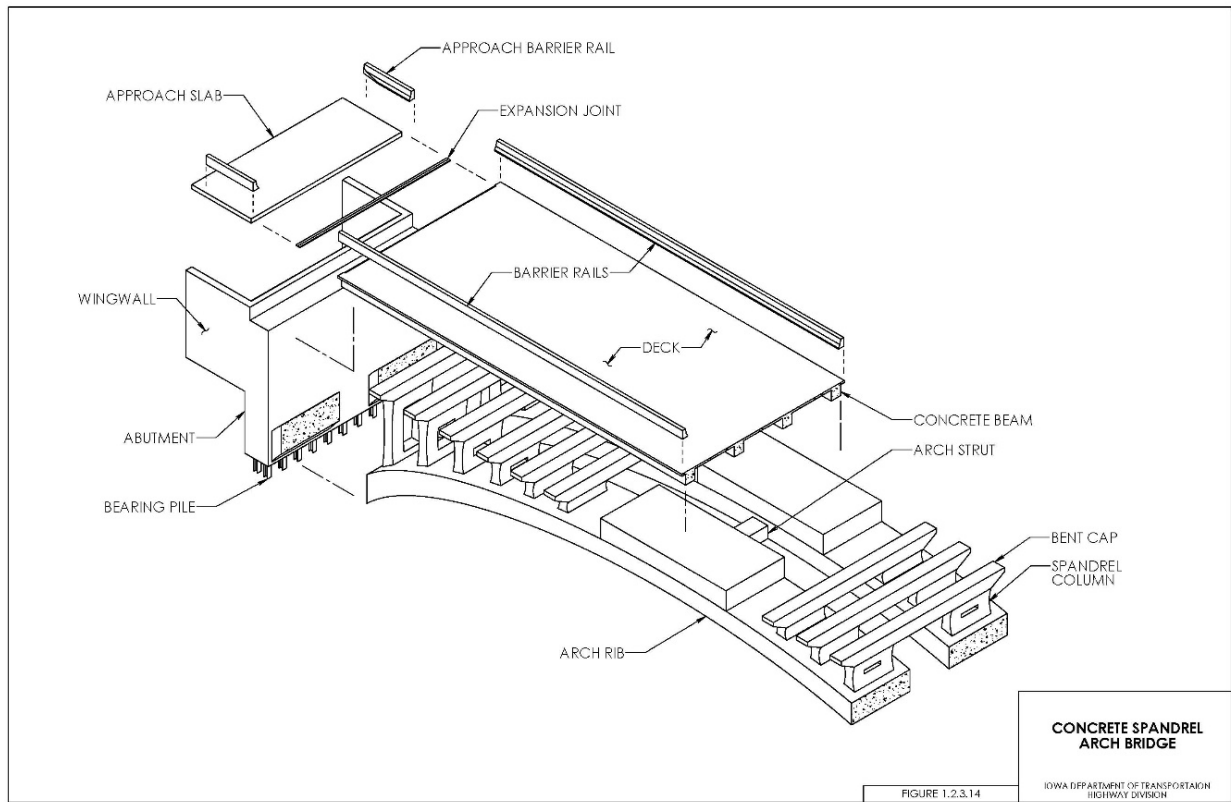

Figure 1.1.1-15 Concrete Open Spandrel Arch Bridge Components

1.1.1.16 Suspension Bridge

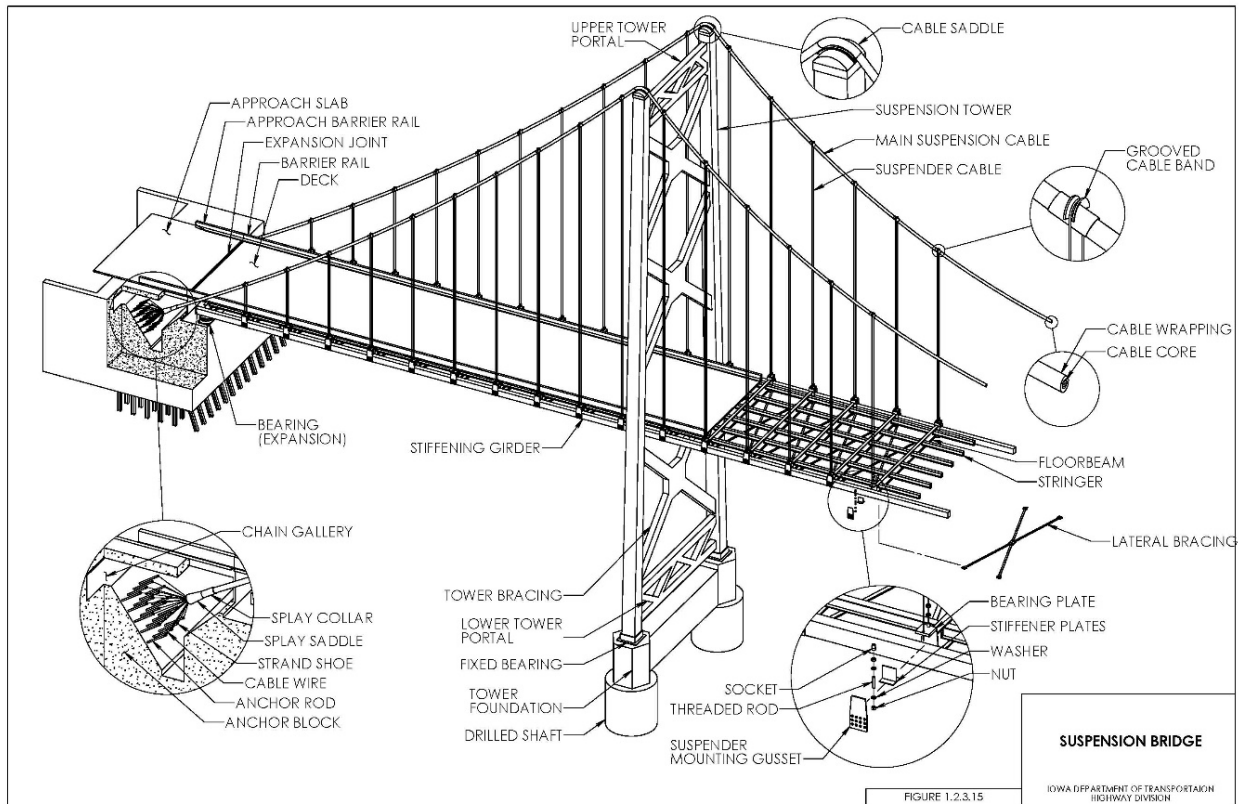

Figure 1.1.1-16 Suspension Bridge Components

1.1.1.17 Cable Stayed Bridge

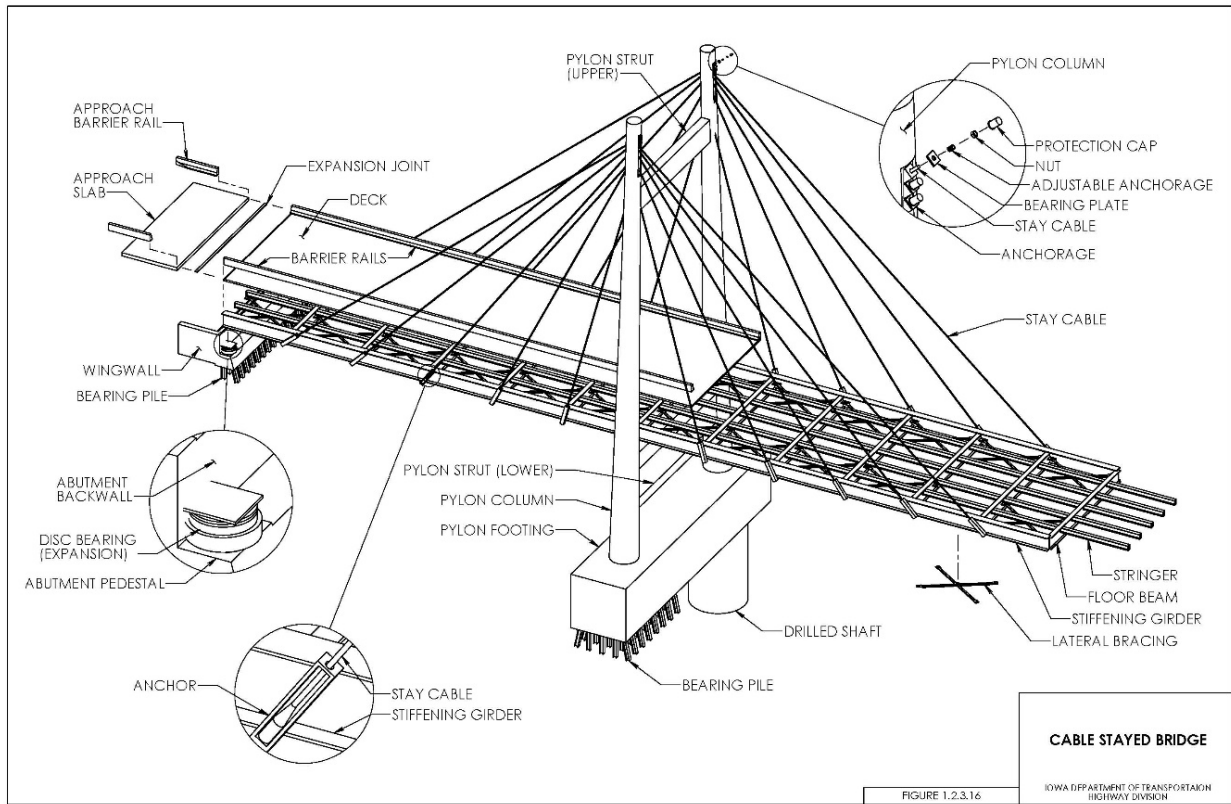

Figure 1.1.1-17 Cable Stayed Bridge Components

1.1.1.18 Culvert

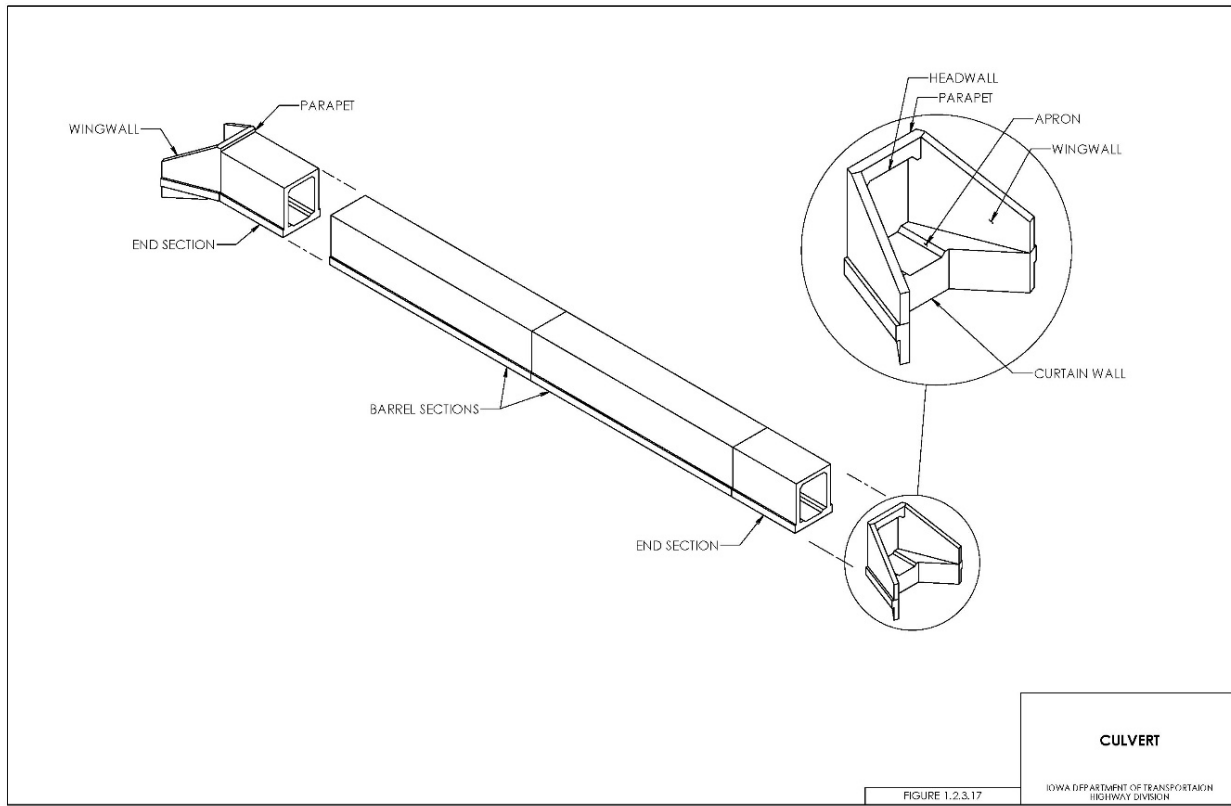

Figure 1.1.1-18 Culvert Components

1.2 HISTORY AND REQUIREMENTS OF NATIONAL BRIDGE INSPECTION STANDARDS

1.2.1 History and Background of NBIS

With the mobility introduced to society during the automobile age and the increased development of the current road system in the U.S., the demands on our nation's bridges have evolved throughout the 20th and 21st centuries. With these growing demands, the responsibility to maintain our nation's bridges for the public's safety has taken on new importance. As bridges have aged and deteriorated, several significant bridge failures became the impetus for developing the current National Bridge Inspection Standards (NBIS) governing how the nation's bridges are inspected, load rated, and maintained. The first significant bridge failure leading to the current NBIS requirements was the December 15, 1967, collapse of the Silver Bridge on Route 35 between Point Pleasant, West Virginia, and Gallipolis, Ohio. In this most devastating bridge collapse in U.S. history in terms of loss of life, 46 people died as a result of an eyebar failure in this eyebar-chain suspension bridge. As a result of the collapse, President Lyndon Johnson called for an investigation, which resulted in the 1968 passing of the Federal Highway Act by Congress, U.S. Code Title 23, Section 151, setting forth the requirement to establish the NBIS.

The 1968 Act delegated responsibility for establishing the NBIS to the Federal Highway Administration (FHWA). In 1970, the American Association of State Highway and Transportation Officials (AASHTO) Manual for Maintenance Inspection of Bridges and the FHWA Bridge Inspector's Training Manual were developed. After publishing the proposed NBIS in the Federal Register and allowing comments from individual states, FHWA published the initial NBIS in 1971.

The NBIS required all public bridges on the Federal-aid highway system to have a Structure Inventory and Appraisal (SI&A) conducted by 1972, and the data reported to FHWA. In 1978, the NBIS was extended to include all public bridges regardless of whether they were on the Federal-aid highway system. Important aspects of the NBIS were the following:

1. All states were required to perform periodic inspections of bridges greater than 20 feet in span length on at least a biennial basis.
2. Data collection was standardized and reported to FHWA.
3. Qualifications for inspection personnel were defined.
4. Training programs were developed and implemented.
5. The Bridge Replacement Program was established to fund bridge replacement on the system.

Over the years, the inspection standards have been updated, often as the result of lessons learned from additional bridge failures. In June 1983, a suspended span of the Mianus River Bridge in Connecticut collapsed, killing three people. The cause of the collapse was traced to the failure of one of the four fracture critical pin and hanger assemblies that supported the suspended span. This collapse focused attention on fracture critical bridges and established national inspection guidelines, additional inspector training, and new fatigue research for these types of structures. FHWA added a new supplement to the Bridge Inspector's Training Manual 70 in 1986: Inspection of Fracture Critical Bridge Members. Fracture Critical Members were defined in the supplement as "Steel tension members whose failure would be expected to result in collapse of the span or bridge." Note that these members are now referred to as Nonredundant Steel Tension Members (NSTMs).

National attention turned to underwater inspections with the collapse of New York's I-90 bridge over the Schoharie Creek in 1987, which resulted in ten deaths. With heavy run-off due to snowmelt and 5.9 inches of rainfall, the bearing soils beneath one of the piers were weakened due to scour. Pier No. 3 collapsed, causing the progressive collapse of Spans 3 and 4.

With over 86 percent of the bridges in the national registry spanning waterways and subject to potential scour, FHWA issued a technical advisory guide in 1988, "Scour at Bridges." In October 1988, the NBIS

was modified based on suggestions made in the 1987 Surface Transportation and Uniform Relocation Assistance Act. The national underwater inspection interval was set at a maximum of 60 months, and scour-critical bridge inspections were initiated.

In 2007, the collapse of the I-35W bridge over the Mississippi River in Minneapolis, Minnesota, again heightened awareness of NBIS requirements and focused attention on the inspection and load rating of gusset plates for truss bridges and on potential overload conditions during construction and repair activities. The conclusions drawn from the collapse of the I-35W bridge, which killed 13 people and injured 145, have resulted in new emphasis on gusset plate inspection, have led to the development of FHWA guidelines for the load rating of gusset plates, and have led to increased scrutiny of conditions and loadings that could be imposed during bridge construction or rehabilitation operations.

On September 5, 2013, a three-span precast prestressed concrete deck beam bridge collapsed in Jefferson County, Illinois, after a truck carrying gravel crossed over it. The subsequent investigation determined that the pile bents, made up of exposed H piles, failed due to severe corrosion of the piles at or below the water line. The inspection report indicated the substructure was in fair to good condition, but because the inspector always performed the inspection when the water level was elevated, he was not able to see the state of corrosion caused by several seasons of wet/dry cycles. In a technical memo issued by the FHWA, states were advised to perform a special inspection of the exposed piles at a different time of the year in order to observe the condition of the piles when the water level was lower.

The Delaware River Turnpike Bridge was opened in 1966; however, there was at least one location with two plug welds filling mis-drilled holes in one of the truss members. These built-in flaws were ground smooth and painted over. However, in January 2017 (50 years later), a bridge painter noticed that a top chord member of one of the approach deck trusses was completely fractured. This fracture caused officials to close the bridge, which carries 42,000 vehicles a day, for seven weeks until a temporary fix could be installed. The two non-visible plug welds in the same cross section of the 14" truss member caused stress risers, resulting in the fracture of this member.

The Hernando DeSoto (I-40) bridge over the Mississippi River in Memphis, Tennessee, carries a major trucking route across the country and is also over a busy shipping channel. On May 11, 2021, a bridge safety inspector noticed a significant partial fracture in a non-redundant steel tension (NSTM) tie-girder member in the eastern main arch span. The bridge was immediately closed to both vehicular and boat traffic, and work to provide a temporary and permanent fix commenced, averting complete fracture. The subsequent investigation revealed that several previous annual cycles of inspection were not hands-on, as is required per NBIS for this type of member. Also, there were no formal documented plans that ensured consistent inspections of this bridge. The investigation also revealed that the crack initiated at a butt weld and had three stages of growth starting on the inside portion of the box section, as did several other similar locations tested as part of the investigation. Periodic ultrasonic testing was recommended for similar bridge scenarios within the state.

On January 28, 2022, the 447-foot-long Fern Hollow Bridge in Pittsburgh, Pennsylvania, collapsed involving nine vehicular occupants, injuring four of them. It was a continuous 3-span, weathering steel, K-frame structure. The National Transportation Safety Board (NTSB) is still investigating this incident but has not yet found any evidence of widespread deficiencies with rigid K-frame superstructure types. Their interim report findings note problems with a lack of sufficient preventative maintenance to clean debris and water accumulation from the weathering steel, allowing continued corrosion and documented significant section losses.

Additional details for some of the above and other historical incidents and actions impacting bridge safety inspection can be found in the FHWA 2022 Bridge Inspector's Reference Manual in Section 10.5. Lessons learned from many of these incidents have also been incorporated into FHWA/NHI Bridge Safety Inspection course material.

The most recent update to the National Bridge Inspection Standards (NBIS) became effective on June 6, 2022, and was revised to address the requirements of MAP-21 as listed here:

1. Extending the applicability of the NBIS to tribally and some privately owned bridges
2. Updating the methodology, training, and qualifications for inspection personnel
3. Updating bridge inspection intervals, considering a risk-based approach
4. Establishing a registry of nationally certified bridge inspectors
5. Ensuring uniformity with the National Tunnel Inspection Standards enacted in 2015
6. Establishing procedures for reporting and monitoring of critical findings
7. Conducting annual reviews for compliance with the NBIS
8. Collection and inventory of element level inspection data for bridges on the National Highway System (NHS)

The new NBIS also incorporates by reference the new Specifications for the National Bridge Inventory (SNBI), which replaces the FHWA Federal Coding Guide, 1995.

This updated Iowa Bridge Inspection Manual is intended to incorporate the lessons from the events noted above into the Iowa Bridge Inspection Program.

1.2.2 Bridge Inspection Organization

With the revisions to the NBIS that became effective in June 2022, state transportation departments were made responsible for inspecting or causing to inspect all highway bridges located on public roads fully or partially within the state's boundaries, with the exception of bridges owned by Federal agencies or Tribal governments. Federal agencies and Tribal governments must, in turn, inspect or cause to inspect all highway bridges located on public roads fully or partially within the respective agency's responsibility or jurisdiction.

To execute the duties set forth above, each state transportation department, Federal agency or Tribal government must include a bridge inspection organization responsible for the following:

- Developing and implementing written statewide bridge inspection policies and procedures
- Maintaining a registry of nationally certified bridge inspectors who are performing the duties of a team leader in the Iowa DOT that includes, at a minimum, a method to positively identify each inspector, inspector's qualification records, inspector's current contact information, and detailed information about any adverse action that may affect the good standing of the inspector
- Documenting the criteria for inspection intervals and for the inspection types identified in these standards
- Documenting the roles and responsibilities of personnel involved in the bridge inspection program
- Managing bridge inspection reports and files
- Performing quality control and quality assurance activities
- Preparing, maintaining, and reporting bridge inventory data
- Producing valid load ratings and when required, implementing load posting or other restrictions
- Managing the activities and corrective actions taken in response to a critical finding
- Managing scour appraisals and scour plans of action
- Managing other requirements of these standards

The NBIS does allow the delegation of the above duties, as is often the case with individual counties or municipalities performing their own inspections. Iowa has delegated inspection duties to local agencies that have bridges under their jurisdiction through Iowa Code section 314.18. However, the delegation of duties does not relieve the state transportation departments or the Federal agencies of any responsibilities under the NBIS. A further requirement is that the state transportation departments or Federal agency and/or Tribal government bridge inspection organizations have a Program Manager, who meets specific required qualifications, to oversee the program.

1.2.3 Required Qualifications of Bridge Inspection Personnel

The Program Manager is the individual in charge of the inspection program for a particular state or Federal agency who has been assigned or delegated the duties and responsibilities for bridge inspection, reporting, and inventory. The Program Manager provides overall leadership for the program and is available to the Team Leaders to provide guidance. A Program Manager must meet all of the following requirements:

- Be a registered professional engineer or have 10 years of bridge inspection experience
- Have successfully completed an FHWA-approved comprehensive bridge inspection training course
- Complete a cumulative total of 18 hours of FHWA-approved bridge inspection refresher training over each 60-month period
- Maintain documentation supporting the satisfaction of mandatory training certifications

A Team Leader is the individual in charge of an inspection team who is responsible for planning, preparing for, performing, and documenting a bridge inspection. In accordance with the NBIS, the Team Leader must be at the bridge site at all times during an inspection. An individual may qualify to be a bridge inspection Team Leader in one of the following four ways:

- Be a registered Professional Engineer, successfully complete an FHWA-approved comprehensive bridge inspection training course and have 6 months of bridge inspection experience.
- Have 5 years of bridge inspection experience and have successfully completed an FHWA-approved comprehensive bridge inspection training course, or
- Have all of the following:
 - A bachelor's degree in engineering from a college or university accredited by or determined as substantially equivalent by the Accreditation Board for Engineering and Technology
 - Successfully passed a National Council of Examiners for Engineering and Surveying Fundamentals of Engineering examination
 - Two years of bridge inspection experience
 - Successfully completed an FHWA-approved comprehensive bridge inspection training course, or
- Have all of the following:
 - An associate degree in engineering from a college or university accredited by or determined as substantially equivalent by the Accreditation Board for Engineering and Technology
 - Four years of bridge inspection experience
 - Successfully completed an FHWA-approved comprehensive bridge inspection training course

In addition, Team Leaders on NSTM inspections must also successfully complete an FHWA-approved training course on the inspection of NSTMs. This requirement must be satisfied by June 6, 2024.

The NBIS requires periodic bridge inspection refresher training for Program Managers and Team Leaders as part of QC and QA. The Iowa DOT has defined periodic as being every five years. Therefore, all

bridge inspection personnel are required to complete the Bridge Inspection Refresher Training course every five years following the completion of the Safety Inspection of In-service Bridges Training Course.

Both Program Managers and Team Leaders are responsible for maintaining documentation providing proof of meeting the qualifications stipulated above. Documentation of training and qualifications can be uploaded into SIIMS. SIIMS tracks training and qualification expiration dates, sending notifications when additional training is required and/or when professional licenses need to be renewed.

The individual charged with overall responsibility for load rating bridges must be a registered professional engineer in the state of Iowa.

Currently, an underwater bridge inspection diver who dove prior June 2022, must have had successfully completed an FHWA-approved comprehensive bridge inspection training course *or* other FHWA-approved underwater diver bridge inspection training course. After June 2022, a new underwater bridge inspection diver must complete FHWA-approved underwater bridge inspection training. The FHWA-approved comprehensive bridge inspection training course no longer will qualify divers after June 2022.

1.2.4 Bridge Inventory Requirements

Each state or Federal bridge inspection agency must prepare and maintain an inventory of all bridges subject to the NBIS within its jurisdiction. Iowa DOT utilizes the Structure Inventory and Inspection Management System (SIIMS) to maintain its bridge inventory.

Certain National Bridge Inventory (NBI) data must be collected and retained by the state or Federal agency for compilation by FHWA. The data must be reported using FHWA-established procedures outlined in SNBI. The SI&A sheet displays important NBI data required by FHWA.

1.3 TYPES OF INSPECTIONS AND INTERVALS

SNBI Item B.IE.01 “Inspection Type” Coding:

1. Initial
2. Routine
3. Underwater
4. NSTM
5. Damage
6. In-Depth
7. Special
8. Service
9. Scour Monitoring

1.3.1 Initial Inspections (1)

An Initial Inspection is the first inspection of a new, or replaced bridge, which becomes a part of the bridge inventory. However, the elements of an Initial Inspection may also apply when there has been a change in the configuration of the bridge due to widening, lengthening, rehabilitation, the addition of supplemental bents, or if there has been a change in the bridge ownership.

The Initial Inspection is a fully documented investigation performed by persons meeting the NBIS qualifications for inspection personnel, and an analytical determination of load capacity must be included with the inspection. The purpose of the inspection is two-fold:

1. To provide all NBI data required by Federal regulations and all other relevant information normally collected by Iowa DOT.

2. To determine the baseline structural condition and to identify and list any existing problems or locations on the structure that may have potential problems or impact public safety.

During the Initial Inspection, the inspector will note any Nonredundant Steel Tension Members (NSTMs) or details aided by a prior review of the plans. Assessments will also be made of other conditions that might warrant special attention. An Initial Inspection for a newly constructed or newly rehabilitated bridge will include all the requirements of an In-Depth Inspection.

1.3.2 Routine Inspections (2)

Routine Inspections are regularly scheduled comprehensive inspections consisting of observations and measurements needed to determine the physical and functional condition of a bridge, to identify any changes from the “Initial” or previously recorded conditions, and to ensure the structure continues to satisfy present service requirements.

The Routine Inspection must fully satisfy the NBIS requirements with respect to maximum inspection interval, the updating of NBI data, and the qualifications of the inspection personnel. These inspections are generally conducted from the deck, from ground or water levels or both, and from permanent work platforms or walkways, if present. Inspections of underwater portions of the substructure are limited to observations during low-flow periods, probing for signs of undermining, or both. Special equipment such as an Underbridge Inspection Vehicle (UBIV), rigging, or staging may be necessary for a Routine Inspection in circumstances where it provides the only practical means of access to areas of the structure being monitored.

The areas of the structure to be closely monitored are those determined by previous inspections, load rating calculations, or both to be critical to load-carrying capacity. If additional close-up, hands-on inspection of other areas is found necessary during the inspection, an In-Depth Inspection of those areas should also be performed in accordance with Section 1.3.6.

The results of a Routine Inspection should be fully documented with appropriate photographs and written notes that include any recommendations for maintenance, repair and for scheduling follow-up In-Depth or Special Inspections, if necessary. The Load Rating Evaluation Form must be completed after a Routine Inspection to determine if re-evaluation of the load ratings is necessary.

Per NBIS for Routine Inspections, each bridge must be inspected at intervals not to exceed the intervals established using the methods below.

- *Regular Intervals:* Each bridge must be inspected at regular intervals not to exceed 24 months, except as noted below.
- *Reduced Intervals:* Iowa DOT may reduce the Routine Inspection intervals below 24 months, when deemed necessary for certain bridges. Factors to consider include structure type, design, materials, age, condition ratings, scour, environment, annual average daily traffic and annual average daily truck traffic, history of vehicle impact damage, loads and safe load capacity, and other known deficiencies. Bridges meeting any of the criteria below, as recorded in the NBI, *must* be inspected at intervals not to exceed 12 months:
 - One or more of the deck, superstructure, substructure, or culvert components is rated in serious or worse condition, as recorded by the Deck, Superstructure, Substructure, or Culvert Condition Rating being coded three (3) or less.
 - The observed scour condition is rated serious or worse, as recorded by the Scour Condition Rating item coded three (3) or less.
 - Note that if the above-noted condition ratings are due to localized deficiencies, a Special Inspection that focuses on those localized conditions can be performed in lieu of a

reduced-interval routine inspection. In such cases, a complete routine inspection must be conducted every 24 months.

- *Extended Intervals:* Iowa is not implementing the 48-month interval criteria for bridges on the Primary Highway System at this time.

1.3.3 Underwater Inspections (3)

Underwater Inspections are used to inspect structural members that are in more than 2' of water at the time of inspection. Note that water depths in excess of 6' must have diver inspection.

Underwater inspections must be performed at intervals not to exceed the intervals established using the methods below:

- *Regular Intervals:* Bridge components requiring underwater inspection must be inspected at intervals not to exceed 60 months, except as noted below.
- *Reduced Intervals:* Certain bridges meeting any of the following criteria must be inspected at intervals not to exceed 24 months:
 - The underwater portions of the bridge are in serious or worse condition, as recorded by the Underwater Inspection Condition item coded three (3) or less.
 - The channel or channel protection is in serious or worse condition, as recorded by the Channel Condition and Channel Protection Condition items coded three (3) or less.
 - The observed scour condition is three (3) or less, as recorded by the Scour Condition Rating item.
 - Where condition ratings are coded three (3) or less due to localized deficiencies, a Special inspection of the underwater portions of the bridge limited to those deficiencies can be used to meet this requirement in lieu of a complete underwater inspection.
- *Extended Intervals:* Certain bridges meeting all of the following criteria may be inspected at intervals not to exceed 72 months. Factors to consider include structure type, design, materials, age, condition ratings, scour, environment, annual average daily traffic and annual average daily truck traffic, history of vehicle/vessel impact damage, loads and safe load capacity, and other known deficiencies:
 - The underwater portions of the bridge are in satisfactory or better condition, as recorded by the Underwater Inspection Condition item coded six (6) or greater.
 - The channel and channel protection are in satisfactory or better condition, as indicated by the Channel Condition and Channel Protection Condition items coded six (6) or greater.
 - Stable for potential scour, Scour Vulnerability item coded A or B, and Scour Condition Rating item is satisfactory or better, coded six (6) or greater.

1.3.4 Nonredundant Steel Tension Member NSTM Inspections (4)

A Nonredundant Steel Tension Member Inspection consists of a hands-on inspection of NSTM components including visual and other nondestructive evaluation. An NSTM Inspection includes the identification of NSTMs and a plan for inspecting such members and defining the inspection procedures to be used. The interval of inspection will be in accordance with the NBIS.

A detailed, close visual inspection is the primary method of detecting cracks. This may require that critical areas be specially cleaned prior to inspection and that additional lighting or magnification be used.

Photographs should be taken, and sketches should be made of the conditions found, and on-site comparison of photographs and sketches should take place at follow-up inspections. Where fracture toughness of the steel is not documented, tests may be necessary to determine the threat of brittle fracture at low temperatures.

NSTMs must be inspected at intervals not to exceed the intervals established using the methods below:

- *Regular Intervals:* Each NSTM must be inspected at intervals not to exceed 24 months, except as noted below.
- *Reduced Intervals:* Iowa DOT may reduce the NSTM Inspection intervals below 24 months when deemed necessary for certain bridges. Factors to consider include structure type, design, materials, age, condition, environment, annual average daily traffic and annual average daily truck traffic, history of vehicle impact damage, loads and safe load capacity, and other known deficiencies. NSTMs meeting the following criteria, as recorded in the NBI, *must* be inspected at intervals not to exceed 12 months:
 - The NSTMs are rated in poor or worse condition, as recorded by the NSTM Inspection Condition item, coded 4 or less.
 - Iowa has additional specific criteria for reduction of NSTM inspection intervals not to exceed 12 months for any of the following criteria:
 - Fatigue cracks have been found in NSTMs at previous inspections.
 - The alignment of NSTMs or sub-elements has measurably changed from the as-built condition.
 - Deterioration in tension areas of the NSTMs has caused the superstructure or substructure to be at a condition rating of 4 or less.
- *Extended Intervals:* Iowa DOT does not allow for NSTM Inspection intervals in excess of 24 months.

Team Leaders who perform field inspections of NSTM bridges must complete the FHWA-NHI Course 130078 “Bridge Inspection Techniques for Nonredundant Steel Tension Members (NSTM)”, previously titled “Fracture Critical Inspection Techniques for Steel Bridges.”

1.3.5 Damage Inspections (5)

A Damage Inspection is an unscheduled inspection used to assess structural damage as the result of unforeseen environmental factors or human actions. Such inspections may be warranted due to events such as an unexpected overload of the bridge; a vehicle-bridge collision; a bridge being struck by an over-height vehicle; a reported deficiency by the public or maintenance personnel; or flood-induced damage from floating flood debris, bridge buoyancy conditions, wash-out of a bridge approach, or scour damage/bridge settlement.

A Damage Inspection may require an on-site assessment of whether a bridge can remain in service; therefore, consultation with a registered professional engineer may be warranted. In addition to determining whether the bridge can remain in service, the Damage Inspection should assess whether the damage to the bridge presents a risk to other facilities below or adjacent to the damaged components. Appropriate equipment should be available, and personnel notified in case partial or full closure of the bridge is necessary and detour routes are required. If the bridge is closed immediately as a precautionary measure, the Damage Inspection should be followed by a structural analysis to determine the bridge’s safe load carrying capacity.

1.3.6 In-Depth Inspections (6)

An In-Depth Inspection is a close-up, hands-on inspection of one or more members above or below the water level to identify any deficiencies not readily detectable using Routine Inspection procedures. This type of inspection can be scheduled independent of a Routine Inspection, though generally at longer intervals, or it may be a follow-up to a Damage or Initial Inspection. Traffic control and special equipment such as a UBIV, staging, and work boats should be provided to obtain access if needed. Personnel with special skills such as divers, rope access inspectors (SPRAT Certified), and riggers may be required. When appropriate or necessary to fully ascertain the existence of or the extent of any deficiencies, nondestructive field tests or other material tests may need to be performed.

An In-Depth Inspection may also include a load rating to assess the residual capacity of the member or members, depending on the extent of the deterioration or damage. Nondestructive load testing may be included to assist in determining a bridge's safe load carrying capacity.

In-Depth Inspections are used to document all bridge elements in a more detailed manner due to conditions that are less than optimal. The definition of In-Depth Inspection for Iowa is slightly different than what is described in the NBIS. Instead of using an In-Depth Inspection for specific elements of a bridge and overlapping Routine with In-Depth inspections, Iowa has chosen to define an entire inspection as either Routine or In-Depth. Criteria have been established to differentiate Routine from In-Depth inspections.

An In-Depth Inspection requires all data fields relevant to the Bridge Deck, Superstructure, Substructure, and Channel to be filled out or updated for the current conditions found. Descriptive inspection notes for the relevant data fields entered are recommended.

The following criteria will be used to determine if a bridge should have an In-Depth Inspection:

- For all NSTM bridges, inspect every 24 months.
- For fatigue vulnerable bridges (bridges with fatigue details), inspect at 24-month or 72-month intervals depending on crack history. If crack history indicates that two or fewer locations have had fatigue cracks develop and these cracks have been arrested, an In-Depth Inspection is required every 72 months.
- For poor condition bridges, inspect every 24 months.
- For all bridges with two or more condition ratings of 5 or less, inspect every 24 months.
- For all culverts with condition ratings of 5 or less, inspect every 24 months.
- For bridges with one condition rating of 5 or less, the inspection can be an In-Depth Inspection if the inspector determines it to be necessary.

Most of the bridges in Iowa are relatively small, and differentiating which elements require an In-Depth Inspection and which can have a Routine Inspection is difficult to track. Therefore, when the In-Depth criteria are met, all elements of a bridge should receive an In-Depth Inspection and documentation. The activities, procedures, and findings should be completely and carefully documented.

1.3.7 Special Inspections (7)

A Special Inspection can be scheduled at the discretion of the bridge owner or the responsible agency. It is used to monitor a particular known member condition or suspected deficiency, or to monitor special details or unusual characteristics of a bridge that does not necessarily have defects. Special Inspections must be performed by a qualified Team Leader familiar with the bridge and available to accommodate the assigned interval of investigation. Note that if the condition ratings for Deck, Superstructure, Substructure or Culvert are low enough to trigger reduced Routine Inspection intervals but are due to *localized* deficiencies, a Special Inspection that focuses on those *localized* deficiencies can be performed in lieu of

a reduced-interval routine inspection. The individual performing the Special Inspection should be carefully instructed regarding the nature of the known deficiency and its functional relationship to satisfactory bridge performance. In this instance, guidelines and procedures on what to observe or measure must be provided, and a timely process to interpret the field results should be in place. Note that a bridge does not need to have any known defects for a Special Inspection to be required by the bridge owner.

At the discretion of the bridge owner, “Other” types of inspections may be used to monitor the performance of bridges or specific bridge components. “Other” inspections will not be part of, nor need to comply with the NBIS.

The determination of an appropriate Special Inspection interval should consider the severity of the known deficiency. Special Inspections usually are not sufficiently comprehensive to meet NBIS requirements for biennial Routine or In-Depth inspections.

A Special Inspection should be scheduled when:

1. Deterioration is progressing at a rate that warrants inspection more frequently than 24 months.
2. Channel degradation or channel movement is progressing at a rate that warrants inspection more frequently than 24 months.
3. Temporary supports are in place.
4. Fatigue cracks have been found in a redundant steel structure. Special Inspections can be stopped when repair has been performed to mitigate the cracks.
5. Fatigue cracks have been found in an NSTM. Special Inspections should continue even after cracks have been mitigated. Only after the potential for any future fatigue cracks has been eliminated can Special Inspections be stopped on a Nonredundant Steel bridge.
6. Collision damage has severely affected the load capacity of the bridge and repairs cannot be done within a reasonable time period. Once repairs have been made, the Special Inspections can be stopped.
7. Section loss has severely affected the load capacity of the bridge. Once repairs or rehabilitation work have been completed, the Special Inspections can be stopped.

1.3.7.1 Special Inspections - Intermediate Fatigue Inspections

For bridges that have NSTMs and also have fatigue-prone details, an Intermediate Fatigue Inspection may be scheduled as a type of Special Inspection. The purpose of an Intermediate Fatigue Inspection is to monitor fatigue-prone details. Another reason for this type of inspection would be to observe and monitor fatigue crack retrofits performed to determine if they have successfully arrested the potential propagation of fatigue cracks. An Intermediate Fatigue Inspection is a hands-on inspection.

Good practice procedures for Intermediate Fatigue Inspections include marking and dating locations where fatigue cracks are present. To accurately determine the ends of fatigue cracks, nondestructive test methods may need to be incorporated to supplement visual investigation. These nondestructive methods may typically include dye penetrant or magnetic particle testing methods.

1.3.7.2 Special Inspections - Pin or Pin and Hanger Inspections

Pin or Pin and Hanger Inspections are inspections that could be required for steel bridges with pinned elements. This might include steel truss bridges pinned at their joints; steel arch bridges pinned at their supports or at their crown; and steel girder, steel stringer, or steel truss bridges with spans suspended by pin and hanger systems. This type of inspection requires specialized equipment and often special access methods to allow for testing of the pin members by nondestructive ultrasonic testing methods. For typical ultrasonic test procedures, a transmitter and a receiver are attached to one end of a pin member. The

transmitter transforms the energy of an electrical voltage into an ultrasonic wave, and the ultrasonic wave travels through the material at a velocity dependent upon the material's properties. The ultrasonic wave travels through the material until the test specimen boundary reflects the signal, and then the reflected signal travels back through the material to a receiver. The receiver converts the mechanical energy back to electrical energy, which is then amplified. The amplified signal, or echo, is displayed on the instrument screen, and if the member contains a discontinuity (that is, a defect), the discontinuity appears as a reflected defect echo on the screen.

If a pin or pin and hanger connects an NSTM, then they should also be considered NSTMs. If the pin and hangers are considered NSTMs, then a hands-on, visual inspection of all elements of the connection is required as part of a regularly scheduled NSTM Inspection. However, because the ultrasonic pin testing usually requires specialized access, such as a manlift or UBIV, to place personnel and the test equipment close to the pin, it also allows for ready access to perform supplementary hands-on inspection of the assembly.

Pin and hanger connections or pinned connections not considered NSTM can be inspected with ultrasonic testing methods at a 60-month interval. This type of inspection should be tracked by designating it as a "Special" Inspection.

1.3.7.3 Other Inspections - Posting Sign Adequacy Inspections

A Posting Sign Adequacy Inspection would typically consist of an inspection to determine if posting signs are being maintained or, in the case of a closed bridge, to determine if barricades are being maintained in place and public access is restricted. This type of inspection could also be used to spot-check a posted bridge to determine if overweight vehicles are complying with posting restrictions.

1.3.8 Scour Monitoring Inspections (8)

Scour Monitoring Inspections are usually performed during or after a triggering storm event as required by a Scour Plan of Action (POA).

Scour Monitoring Inspections are used to assess an existing bridge's vulnerability to scour and stream instability. In addition, Scour Inspections allow for documentation of scour changes since the previous inspection. The visual inspection should document the existing condition of the bridge, including, but not limited to, pier and abutment type; foundation depth (based on existing plans or physical probing in the field); substructure location and alignment relative to the stream; scour depth at abutments and piers; bridge skew; condition or absence of scour countermeasures; stream aggradation or degradation; upstream and downstream channel stability; potential or presence of debris; lateral movement of stream; and bed and bank soil material. The visual inspection should include photo documentation of the bridge deck, roadway profile, abutment walls, piers, and upstream/downstream channel configurations, as a minimum.

The information obtained from the visual inspection can be used to evaluate the scour potential from a flood event of a known return interval through the use of analytical tools. Hydraulic models and equations in the HEC-18 computer program are commonly used for the analysis. These results, in conjunction with the field inspection and a structural analysis, can then be used to assess existing or potential scour and, if necessary, establish a formal Plan of Action for management of the scour potential of the structure to protect public safety.

1.4 IOWA DOT INSPECTION PROGRAM POLICIES

1.4.1 Safety

By its nature, bridge inspection includes inherent dangers. Inspection staff are often working from elevated heights and often over water; they are working in and around active traffic; they are often

working in challenging weather conditions; in working around the abutments of bridges, they are often working along steep, slippery slopes where footing can be difficult; and they must constantly focus on gathering the pertinent information required for a bridge inspection while also keeping their own safety and the safety of their coworkers and the traveling public in mind. Each bridge inspector should remember they are responsible for their own personal safety as well as the safety of others impacted by their work. To that end, some policies and common-sense procedures are needed to protect staff from the dangers of bridge inspection, to help them recognize hazards, implement controls, and to give them the ability to select, use, and maintain tools and equipment in their work to minimize and, if possible, eliminate accidents, injuries, and near misses.

Generally, the causes of accidents can be traced to two root causes: human error and equipment failure. Human errors can, in turn, be broken down into a number of factors, which may include improper attitude, horseplay, personal limitations, physical impairments, boredom, thoughtlessness, and taking shortcuts. Therefore, bridge inspectors must practice good work habits to minimize the dangers they may encounter on the job. Inspectors must always use safe practices taught in FHWA inspection certification classes when performing bridge inspection activities. For example, it is Iowa DOT's policy that inspectors will be tied-off 100 percent of the time when working in the basket of a manlift or UBIV or when using assisted climbing techniques to access bridge elements for inspection. Failure to maintain this 100 percent tied-off policy will unnecessarily expose the inspector to fall hazards that could otherwise be avoided. When working outside the basket of a manlift or UBIV, the inspector should be tied-off to a fixed object rather than the basket, in case the manlift or UBIV should move.

Environmental factors can also be a source of injury. Stinging insects, spiders, snakes, and nesting animals can startle or surprise a bridge inspector causing injury or sudden unexpected movements that could result in a fall. The presence of poison ivy, poison oak, and electric cattle fences can cause on-the-job injury or, at best, discomfort. In some cases, bridge configurations constituting confined spaces could have limited access entrances, poor oxygen content, or toxic gases.

With the physical demands of bridge inspection activities, proper work habits and mental attitude are important. Inspectors also need to be well rested and alert for their job assignments, maintain good physical health, and will not be under the influence of drugs or alcohol on the job. Even over-the-counter medications can cause impairments that can affect balance or cause drowsiness and should be used with caution. Good work practices also include common sense activities such as keeping a clean, uncluttered work environment and using tools and equipment properly and for only their intended use. Inspectors who are controlling the basket of a manlift or UBIV must be trained in the operation of that particular type of equipment so movement of the basket is performed smoothly without sudden movements that could surprise a coworker in the basket. Training in the operation of the particular access equipment will also minimize the potential for damaging the equipment or members of the bridge being inspected. Training must meet ANSI A92.22 and A92.24.

The Occupational Safety and Health Administration (OSHA) applies different regulations depending on the nature of the work activity. The General Industry standards (OSHA CFR 1910) apply to activities like bridge maintenance or inspection, surveying, or wetland assessments. The Construction standards (OSHA CFR 1926) apply to new work on bridges, roadways, or other structures. Work, including bridge inspections, will be considered to be a maintenance activity when it meets the following criteria: It is work done for the purposes of making or keeping a structure, fixture or foundation (substrates) in proper condition in a routine, scheduled, or anticipated fashion – work that is done to keep a structure in its existing state, preventing failure or decline. Inspections related to the monitoring of work performed by a construction contractor will be considered construction activity.

Inspection personnel should receive awareness training for safety hazards they may encounter on the job. This safety training may include knowledge of proper procedures when working around active traffic, fall protection training, awareness training for confined spaces, ladder safety training, training for working on

railroad property, and training for work over water. Inspectors are to utilize the entirety of training included in all FHWA Bridge Inspection Certification programs. Safety training is required and provided by the DOT through their on-line training system, where training is tracked annually for all inspectors.

When working over water, particularly if the inspector is not tied-off, a personal floatation device (PFD) or a safety boat with a life ring and two-way communication must be used. Inspectors must be familiar with the boat safety requirements summarized by the Department of Natural Resources (DNR) Handbook of Iowa Boating Laws. PFDs will be worn at all times while in a boat or on a barge. When it is determined that there is a hazard of falling from a position near or over the water or slipping or sliding into the water from an embankment, a PFD will be used. Considerations when assessing the hazard level are depth of water, water current, and the type of terrain on the embankment.

The inspection Team Leader’s responsibilities include supervising job procedures and ensuring safe practices are being followed. The Team Leader needs to set a good example for the inspection staff, enforce safety policies, and institute corrective actions when these policies are not followed. It is good practice that the Team Leader performs a safety briefing on the first day of inspection for a bridge and on subsequent days when work conditions or personnel working on the bridge have changed. Topics to be discussed at the safety briefing might include:

- Individual worker assignments
- Use of the “buddy” system
- Any special considerations for the particular bridge being inspected, including potential electrical hazards from power facilities on the bridge or from overhead power lines
- Safety procedures for work over water, other roadways, or railroads
- Weather conditions
- The types of traffic control that will be used
- Methods of bridge access that will be used, such as ladders, manlifts, UBIVs, waders, and assisted climbing
- Safe working zones
- Location and phone number of nearest first responders or medical services
- Communication protocol, including two-way radios and cell phones with cell phone numbers for all staff on the job and for the local District office.

Inspection personnel will use appropriate protective clothing and Personal Protective Equipment (PPE) when performing bridge inspection activities.

- Clothing worn should be properly sized (neither too loose nor too tight) and appropriate for the weather conditions.
- Leather work boots with traction lug soles should be worn, and safety shoes or boots with toe-impact protection meeting the requirements of ASTM F2413-05, ANSI Z41-1991, or the latest version are required to be worn in work areas where personnel may be carrying or handling materials such as parts or heavy tools that could be dropped and where objects might fall onto or equipment could run over the feet.
- Work gloves should be worn to protect against sharp edges and excessively hot or cold steel.
- While a tool belt or pouch may be worn to provide ready access to frequently used tools, the tools must be secured to prevent them from falling on passing vehicular traffic.
- Additional PPE shall include an ANSI 107, Class 2 or 3 High Visibility Safety Vest (Class 3 is rated for traffic speeds above 50 mph).

- If working at night outside the cab of a vehicle, high visibility pants and head gear are also required.
- Hard hats shall meet the requirements of ANSI Z89.1.
- Safety goggles or safety glasses with side shields should be worn whenever chipping concrete or hammering on bridge members, and ear protection should be worn if working around loud pneumatic or power equipment.
- A dust mask or properly fitted respirator should be worn when working in particularly dusty conditions or in the presence of bird droppings to prevent contracting Histoplasmosis, a disease contracted from contact with microscopic fungi borne from decomposing biological fluids such as bird droppings.
- When walking or working on an unprotected surface 6 feet or more from the ground or a lower level, or when working from the basket of a manlift or UBIV or using assisted climbing techniques, the inspector will wear a properly adjusted full-body harness, shock absorbing lanyard with double locking snap hooks, and a cross-arm strap with a D-ring (if needed). The harness must meet the requirements of ANSI A10.14, ANSI/ASSE Z359, or the latest version of 29 CFR 1910.66, 1926.104 or 1926.502.

1.4.2 Media Relations

Elements of the Iowa DOT Bridge Inspection Program and individual bridge records available in SIIMS may be subject to open public records laws. For example, data is annually made available to FHWA and the public regarding the number and locations of Poor bridges within the State. However, if approached by a member of the press about the condition of a specific bridge or bridges, inspectors must defer comment and refer the individual to the Iowa DOT Outreach and Development Bureau.

1.5 STATEWIDE INSPECTION PROGRAM POLICIES

1.5.1 Timelines for Completion of Inspections and Reports

For Routine, In-Depth, NSTM, Underwater, and Special Inspections, SI&A data must be entered into SIIMS within 90 days of the date of the inspection completion.

For existing bridge modifications that alter previously recorded data and for new bridges, the SI&A data must be entered into the State or Federal agency inventory within 90 days after the completion of work for all bridges subject to the NBIS.

For changes in load restrictions or closure status, the SI&A data must be entered into SIIMS within 90 days after the change in status of the structure.

1.5.2 Standardized Bridge Orientation and Labeling Conventions

To promote uniformity in reporting inspection data, all bridge components will be labeled using the following numbering convention consistent with the progression of mileposts on the State highway system:

For bridges on a roadway with a north/south designation, bridge substructure components shall be numbered in increasing order starting at the south end of the bridge, relative to the direction designation, and progressing toward the north regardless of the direction of traffic flow. Thus, the south abutment would be referred to as the “near” abutment and the north abutment would be referred to as the “far” abutment. Likewise, interior supports would be numbered Pier No. 1 at the southernmost interior support and would increase in number proceeding to the north. Span

numbers would also increase in number from south to north. Floorbeams and diaphragms are numbered from the near end to the far end of each span. The first floorbeam or diaphragm over an abutment or pier will be designated as #0. The numbering continues consecutively through the span to the next substructure unit where the numbering begins again at #0. Truss panel points would similarly increase from south to north from the near end to the far end of a span. Thus, the truss panel point at the south support would be L0 for a lower chord panel point (or U0 for an upper chord panel point) and panel point L1 (or U1) for a first interior panel point. Beam or stringer lines would be numbered increasing from left to right, with Beam Line No. 1 at the westernmost beam and increasing in number to the easternmost beam. Likewise, pile numbers for exposed piles at abutments or pile bents would be numbered in increasing order from left to right (west to east).

For bridges on a roadway with an east/west designation, bridge substructure components shall be numbered in increasing order starting at the west end of the bridge, relative to the direction designation, and progressing toward the east regardless of the direction of traffic flow. Thus, the west abutment would be referred to as the “near” abutment and the east abutment would be referred to as the “far” abutment. Likewise, interior supports would be numbered Pier No. 1 at the westernmost interior support and would increase in number proceeding to the east. Span numbers would also increase in number from west to east. Floorbeams and diaphragms are numbered from the near end to the far end of each span. The first floorbeam or diaphragm over an abutment or pier will be designated as #0. The numbering continues consecutively through the span to the next substructure unit where the numbering begins again at #0. Truss panel points would similarly increase from west to east from near end to far end of a span. Thus, the truss panel point at the west support would be L0 for a lower chord panel point (or U0 for an upper chord panel point) and panel point L1 (or U1) for a first interior panel point. Beam or stringer lines would be numbered increasing from left to right, with Beam Line No. 1 at the northernmost beam and increasing in number to the southernmost beam. Likewise, pile numbers for exposed piles at abutments or pile bents would be numbered in increasing order from left to right (north to south, regardless of the traffic flow direction on the bridge).

1.5.3 Critical Findings/Emergency Response

A Critical Finding is a structural or safety-related deficiency that requires immediate action to ensure public safety. Critical structural and safety-related deficiencies found during the field inspection or as a result of a structural analysis of the bridge should be immediately brought to the attention of the bridge owner or responsible agency by the Program Manager or Team Leader if a safety hazard is present. This process alerts the bridge owner so that 1) timely action is taken to ensure the safety of the traveling public, 2) damage or deterioration can be repaired in a proper and timely manner, and 3) the damage and repairs are documented in the bridge file. The process also aids in identifying problem areas that affect other bridges with similar details so follow-up inspections can be performed if needed.

A standard Critical Findings Report form has been incorporated into SIIMS. Conditions requiring a Critical Findings Report shall include, but are not limited to, any one of the following:

- A partial or complete collapse of a bridge
- A structural or other defect posing a definite and immediate public safety hazard that requires partial or complete closure of the bridge. Deficiencies could include damage, corrosion with extensive section loss, major delamination, deflection, rotation, settlement, spalling, and /or substructure damage due to scour. Basically, any deficiency that affects the original designed load path(s) of the bridge.
- A condition rating of 2 or less for any of the following SNBI items:
 - B.C.01 Deck Condition Rating

- B.C.02 Superstructure Condition Rating
- B.C.03 Substructure Condition Rating
- B.C.04 Culvert
- B.C.09 Channel Condition Rating
- B.C.11 Scour Condition Rating

In cases where it is determined the bridge could be used safely at a lower posted load limit, the bridge may remain open if it is immediately posted at the reduced limit. Another example that avoids bridge closure, could be the case where the structural or safety issue only impacts a portion of a bridge (i.e., the fascia girder) and the bridge could remain open with a shoulder closure over the compromised member. At the discretion of a bridge owner, other conditions, not specified in this manual, may be designated that would require the preparation of a Critical Finding Report.

1.5.4 Inspection Intervals for Non-Regulated Structures

1.5.4.1 Pedestrian Bridges

The NBIS does not define the required interval for inspection of non-vehicular bridges, such as pedestrian bridges. The owner should develop a protocol for the inspection interval for pedestrian bridges.

1.5.4.2 Culverts

The definition of a bridge, provided in Appendix TBD of this manual, addresses single cell box culverts with spans greater than 20 feet and multiple cell culverts with an aggregate length between extreme ends of openings that is greater than 20 feet. Therefore, a box culvert meeting the criteria under the definition for a bridge shall fall under the required inspection intervals defined in the NBIS.

For box culverts that do not fall within the NBIS criteria for the definition of a bridge, the owner shall develop a protocol for the required inspection interval.

1.5.4.3 Privately Owned Structures

Privately owned structures not open to public use are not governed by NBIS regulations. When a privately owned bridge is connected to a public road on both ends of the bridge, the NBIS regulations apply. The bridge owner must have a Program Manager who is assigned the NBIS responsibilities. The bridge owner may retain a consultant to perform the duties of the Program Manager.

1.5.5 Temporary Structures

Any replacement structure which is expected to remain in place without further project activity, other than maintenance, for a significant period of time, shall not be considered temporary. Under such conditions, that structure, regardless of its type, shall be considered the minimum adequate to remain in place. The structure must be added to the NBI and evaluated accordingly.

If a structure has been taken out of service due to condition, collapse, or removal, and a temporary structure or low water crossing has been installed, the SNBI data for the original structure should have the following coding:

- B.PS.01 = T_ (for Temporary) – Temporary bridge in place to carry traffic while the permanent bridge is closed and awaiting repair, rehabilitation, or replacement.
 - TO = Temporary bridge, open with no restriction.
 - TA = Temporary bridge, load posting is recommended but not in-place or legally enforceable.

- TP = Temporary bridge, posted for load.
- TR = Temporary bridge, reduced loading by limiting speed, lanes/vehicles or commercial vehicles.
- TD = Temporary bridge, load posted; however, load posting reduction is recommended but not yet implemented.
- TM = Temporary bridge, enforceable load posting, but one or more load posting signs are missing/illegible.
- C = Closed to traffic.
- B.C.01 = 0 – Failed.
- B.C.02 = 0 – Failed
- B.C.03 = 0 – Failed
- If applicable, B.C.04 = 0 – Failed
- B.LR.05 = Inventory Load Rating Factor
- B.LR.06 = Operating Load Rating Factor

There are items that are to be coded according to the temporary structure's conditions. The items that are to be coded are as follows:

- B.H.12 – Highway Maximum Usable Vertical Clearance
- B.H.16 – Highway Maximum Usable Surface Width
- B.H.13 – Highway Minimum Vertical Clearance
- B.H.15 – Highway Minimum Horizontal Clearance, Right
- B.H.16 - Highway Minimum Horizontal Clearance, Left

The original structure must be removed from the NBI if no work has been done to replace it within five years of the time the bridge was closed. If, after the original structure is removed from the NBI, the temporary structure qualifies as a bridge, it must be added to the NBI and evaluated accordingly.

1.5.6 Temporary Supports

A structure that has temporary supports is to be evaluated as if no temporary supports are in place. Most SNBI items shall be determined as if the temporary supports are not in place. Condition ratings and load ratings shall not take into account the effect of the temporary supports. The SNBI Load Posting Status Item B.PS.01 shall be coded as follows:

- a. SO = Supported, open with no restriction.
- b. SA = Supported, load posting is recommended but not in-place or legally enforceable.
- c. SP = Supported, posted for load.
- d. SR = Supported, reduced loading by limiting speed, lanes/vehicles or commercial vehicles.
- e. SD = Supported, load posted; however, load posting reduction is recommended but not yet implemented.
- f. SM = Supported, enforceable load posting, but one or more load posting signs are missing/illegible.
- g. C = Closed to traffic

Reduced inspection intervals should be considered on a case-by-case basis for temporary supports. If the temporary supports are to remain in place for more than five years, the supports are no longer considered temporary, and the structure shall be evaluated accordingly.

Page Intentionally Left Blank